

FPO - Do Not Print

HONDA RED
(Pantone 186C)
CMYK: 0,100,90,0

Manager	Assistant Manager / Supervisor	OC Lead
		Approved

Trim Size: 128 x 182 mm

Models sold in and used in California:

The removal or modification of evaporative emission-related parts on this OHRV is illegal. Violators may be subject to civil and/or criminal penalties as provided under California and federal law.

OWNER'S MANUAL

2026 CRF300F

Manager

AMgr / Supervisor

QC Lead

Approved



Spine

Manager	Assistant Manager / Supervisor	QC Lead
		Approved



31K99Q71
00X31-K99-Q710

© 2026 Honda Motor Co., Ltd.
All Rights Reserved

Printed in the U.S.A.

This manual should be considered a permanent part of the motorcycle and should remain with the motorcycle when it is resold.

This publication includes the latest production information available before printing.
Honda Motor Co., Ltd. reserves the right to make changes at any time without notice and without incurring any obligation.

No part of this publication may be reproduced without written permission.

This vehicle pictured in this owner's manual may not match your actual vehicle.

© Honda Motor Co., Ltd. 2025

**2026
Honda CRF300F
OWNER'S MANUAL**

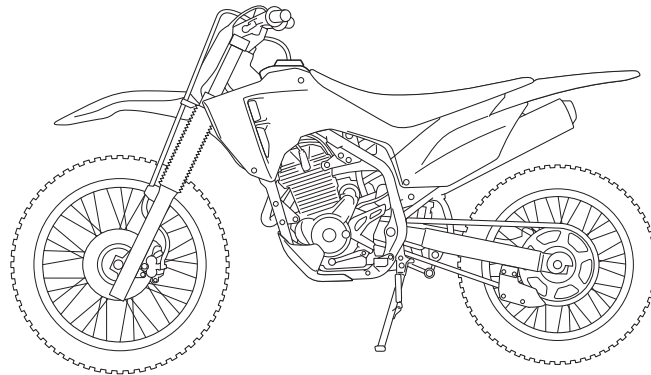

FOR OFF-ROAD USE ONLY

This vehicle is designed and manufactured for off-road use only.

USA only:

It conforms to US EPA Noise Emission regulations, but does not conform to Federal Motor Vehicle Safety Standards or US EPA On Highway Exhaust Emission regulations, and operation on public streets, roads, or highways is illegal. The vehicle is equipped with a USDA qualified spark arrester. Obey local laws and regulations.

It conforms to US EPA, California, and Environment and Climate Change Canada (ECCC) emission regulations for off-road motorcycles.

A Few Words About Safety

Your safety, and the safety of others, is very important. And operating this motorcycle safely is an important responsibility.

To help you make informed decisions about safety, we have provided operating procedures and other information on labels and in this manual. This information alerts you to potential hazards that could hurt you or others.

Of course, it is not practical or possible to warn you about all hazards associated with operating or maintaining a motorcycle. You must use your own good judgment.

You will find important safety information in a variety of forms, including:

- **Safety Labels** – on the motorcycle.
- **Safety Messages** – preceded by a safety alert symbol  and one of three signal words: **DANGER**, **WARNING**, or **CAUTION**.

These signal words mean:

Safety Messages

A Few Words About Safety

⚠ DANGER

You **WILL** be **KILLED** or **SERIOUSLY HURT** if you don't follow instructions.

⚠ WARNING

You **CAN** be **KILLED** or **SERIOUSLY HURT** if you don't follow instructions.

⚠ CAUTION

You **CAN** be **HURT** if you don't follow instructions.

- **Safety Headings** – such as Important Safety Reminders or Important Safety Precautions.
- **Safety Section** – such as Motorcycle Safety.
- **Instructions** – how to use this motorcycle correctly and safely.

This entire book is filled with important safety information – please read it carefully.

Contents

These pages give an overview of the contents of your owner's manual. The first page of each section lists the topics covered in that section.

Introduction

Motorcycle Safety 1
Important safety information, precautions about loading, accessories, and modifications, and the location of safety labels.

Operating Controls..... 11
The location, function, and operation of the throttle, brakes, clutch, and other basic controls.

Before Riding 19
The importance of wearing a helmet and other protective gear, plus how to make sure you and your motorcycle are ready to ride.

Basic Operation & Riding25
How to start and stop the engine, shift gears, and brake. Also, riding precautions.

Servicing Your Honda35
Why your motorcycle needs regular maintenance, what you need to know before servicing your Honda, a maintenance schedule, and instructions for specific maintenance items.

Contents

Tips.....	115	Index.....	164
How to transport and store your motorcycle, and how to be an environmentally responsible rider.		Quick Reference Handy facts about fuel, engine oil, tire sizes, and air pressures.	
Taking Care of the Unexpected	125		
What to do if you have a flat tire, your engine won't start, etc.			
Technical Information	141		
ID numbers, technical specifications, and other technical facts.			
Consumer Information	157		
Information on warranties and how to get Honda service manuals.			

Introduction

Congratulations on choosing your Honda off-road motorcycle.

When you own a Honda, you're part of a worldwide family of satisfied customers – people who appreciate Honda's reputation for building quality into every product.

Your Honda was designed as a recreational motorcycle for off-road use by one rider only.

Before riding, take time to get acquainted with your motorcycle and how it works. To protect your investment, we urge you to take responsibility for keeping your motorcycle well maintained. Scheduled service is a must, of course. But it's just as important to observe the break-in guidelines, and perform all the pre-ride and other periodic checks detailed in this manual.

Introduction

We also recommend that you read the owner's manual before you ride. It's full of facts, instructions, safety information, and helpful tips. To make it easy to use, the manual contains a detailed list of topics at the beginning of each section and an index at the back of the book.

As you read this manual, you will find information that is preceded by a **NOTICE** symbol. This information is intended to help you avoid damage to your Honda, other property, or the environment.

Read the Warranties Booklet (page 159) thoroughly so you understand the coverages that protect your new Honda and are aware of your rights and responsibilities.

Introduction

Whenever you ride, tread lightly. By staying on established trails and riding only in approved areas, you help protect the environment and keep off-road riding areas open for the future.

If you have any questions, or if you ever need a special service or repairs, remember that your Honda dealer knows your motorcycle best and is dedicated to your complete satisfaction.

Please report any change of address or ownership to your dealer so we will be able to contact you concerning important product information.

You may also want to visit our website at
USA: www.powersports.honda.com.
Canada: www.honda.ca.

Happy riding!

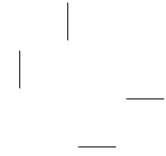
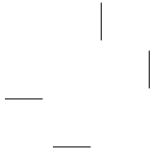

This page intentionally left blank.

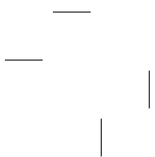

Motorcycle Safety

This section presents some of the most important information and recommendations to help you ride your motorcycle safely. Please take a few moments to read these pages. This section also includes information about the location of safety labels on your motorcycle.

Important Safety Information.....	2
Loading, Accessories & Modifications.....	5
Loading	5
Accessories & Modifications	7
Safety Labels.....	9

Important Safety Information

Your motorcycle can provide many years of service and pleasure – if you take responsibility for your own safety and understand the challenges you can meet while riding.

There is much that you can do to protect yourself when you ride. You'll find many helpful recommendations throughout this manual. The following are a few that we consider to be most important.

Always Wear a Helmet

It's a proven fact: helmets significantly reduce the number and severity of head injuries. So always wear an approved motorcycle helmet. We also recommend that you wear eye protection, sturdy boots, gloves, and other protective gear (page 20).

Never Carry a Passenger

Your motorcycle is designed for one person only. There are no handholds, footrests, or seat for a second person – so never carry a passenger. A passenger could interfere with your ability to move around to maintain your balance and control of the motorcycle.

Ride Off-road Only

Your motorcycle is designed and manufactured for off-road use only. The tires are not made for pavement, and the motorcycle does not have turn signals and other features required for use on public roads. If you need to cross a paved or public road, get off and walk your motorcycle across.

Important Safety Information

Take Time to Learn and Practice

Developing off-road riding skills is a gradual, step-by-step process. Start by practicing at low speeds in a safe area and slowly build your skills. Personal instruction from an experienced rider can also be valuable.

If you need assistance, ask your dealer about riding groups in your area.

Also be sure to read the *Tips & Practice Guide for the Off-Highway Motorcyclist* booklet that came with your motorcycle (USA only).

Be Alert for Off-road Hazards

The terrain can present a variety of challenges when you ride off-road. Continually “read” the terrain for unexpected turns, drop-offs, rocks, ruts, and other hazards. Always keep your speed low enough to allow time to see and react to hazards.

Ride within Your Limits

Pushing limits is another major cause of motorcycle crashes. Never ride beyond your personal abilities or faster than conditions warrant. Remember that alcohol, drugs, fatigue, and inattention can significantly reduce your ability to make good judgments and ride safely.

Important Safety Information

Don't Drink or use Drugs and Ride

Alcohol or drugs and riding don't mix. Even one alcoholic drink can reduce your ability to respond to changing conditions, and your reaction time gets worse with every additional drink. The same is true for drug use. Don't drink or use and ride, and don't let your friends do it either.

Keep Your Honda in Safe Condition

It's important to keep your motorcycle properly maintained and in safe riding condition. Having a breakdown can be difficult, especially if you are stranded off-road far from your base. To help avoid problems, inspect your motorcycle before every ride and perform all recommended maintenance.

Loading, Accessories & Modifications

Your Honda was designed as a rider-only motorcycle. It was not designed to carry a passenger or cargo. A passenger or cargo could interfere with your ability to move around to maintain your balance and control of the motorcycle.

In addition, exceeding the weight limits or carrying an unbalanced load can seriously affect your motorcycle's handling, braking, and stability. Adding accessories or making modifications that change this motorcycle's design and performance can also make it unsafe. Also, the weight of any accessories will reduce the maximum load the motorcycle can carry.

More specific information on load limits, accessories, and modifications follows.

Loading

How much weight you put on your motorcycle, and how you load it, are important to your safety. If you decide to carry cargo, you should be aware of the following information.

⚠ WARNING

Overloading or carrying a passenger can cause a crash and you can be seriously hurt or killed.

Follow all load limits and other loading guidelines in this manual.

Loading, Accessories & Modifications

Load Limits

Following are the load limits for your motorcycle:

Maximum weight capacity

= 220 lb (100 kg)

Includes the weight of the rider and any accessories.

Loading Guidelines

As discussed on page 5, we recommend that you do not carry any cargo on this motorcycle. However, if you decide to carry cargo, ride at reduced speeds and follow these common-sense guidelines:

- Keep cargo small and light. Make sure it cannot easily be caught on brush or other objects, and that it does not interfere with your ability to shift position to maintain balance and stability.

- Place weight as close to the center of the motorcycle as possible.
- Do not attach large or heavy items (such as a sleeping bag or tent) to the handlebar, fork, or front fender.
- Make sure that all cargo is tied down securely.
- Never exceed the maximum weight limit.
- Check that both tires are inflated properly (page 93).

Loading, Accessories & Modifications

Accessories & Modifications

Modifying your motorcycle or using non-Honda accessories can make your motorcycle unsafe.

Before you consider making any modifications or adding an accessory, be sure to read the following information.

⚠ WARNING

Improper accessories or modifications can cause a crash in which you can be seriously hurt or killed.

Follow all instructions in this owner's manual regarding modifications and accessories.

Accessories

We strongly recommend that you use only Honda Accessories that have been specifically designed or approved and tested for your motorcycle. Because Honda cannot test all other accessories, you must be personally responsible for proper selection, installation, and use of non-Honda accessories. Check with your dealer for assistance and always follow this guideline:

- Make sure the accessory does not reduce ground clearance and lean angle, limit suspension travel or steering travel, alter your riding position, or interfere with operating any controls.

Loading, Accessories & Modifications

Modifications

We strongly advise you not to remove any original equipment or modify your motorcycle in any way that would change its design or operation. Such changes could seriously impair your motorcycle's handling, stability, and braking, making it unsafe to ride.

We also advise you not to make any modifications or remove any equipment (such as the USDA qualified spark arrester or emission control system components) that would make the motorcycle illegal in your area.

Safety Labels

This page shows the locations of safety labels on your motorcycle. Some labels warn you of potential hazards that could cause serious injury. Others provide important safety information. Read these labels carefully and don't remove them.

If a label comes off or becomes hard to read, contact your dealer for a replacement.

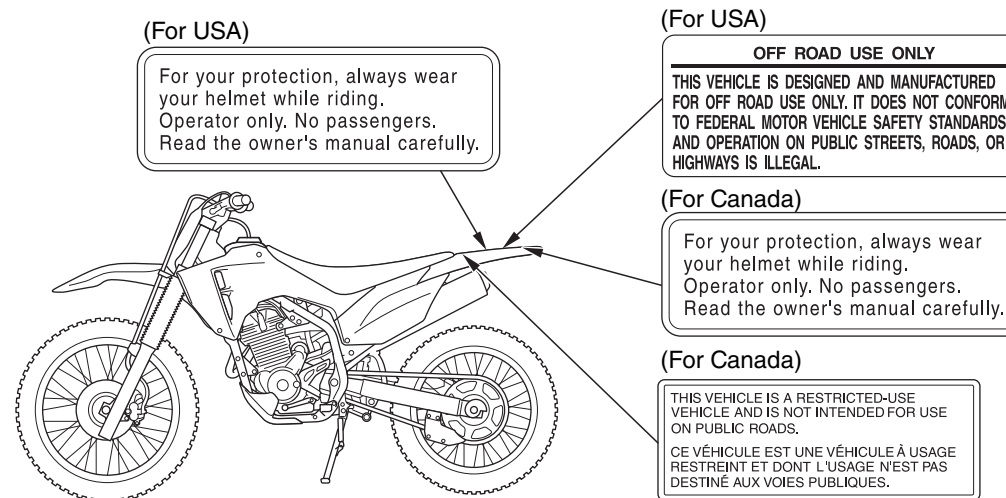

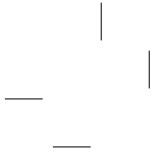

This page intentionally left blank.

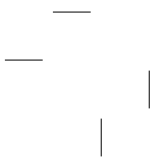

Operating Controls

When you ride off-road, you need to operate the throttle, clutch, brakes, and other controls without stopping to look at them. Read this section carefully before you ride. It describes the location, function, and operation of all the basic controls on your motorcycle.

Operation Component Locations	12
Operating Controls	15
Ignition Switch.....	15
Start Button	16
Engine Stop Button	16
Front Brake Lever	16
Throttle.....	16
Clutch Lever.....	17
Shift Pedal	17
Rear Brake Pedal.....	17
Side Stand	17
PGM-FI Malfunction Indicator Lamp (MIL).....	18
Fuel Reserve Indicator	18

Operation Component Locations

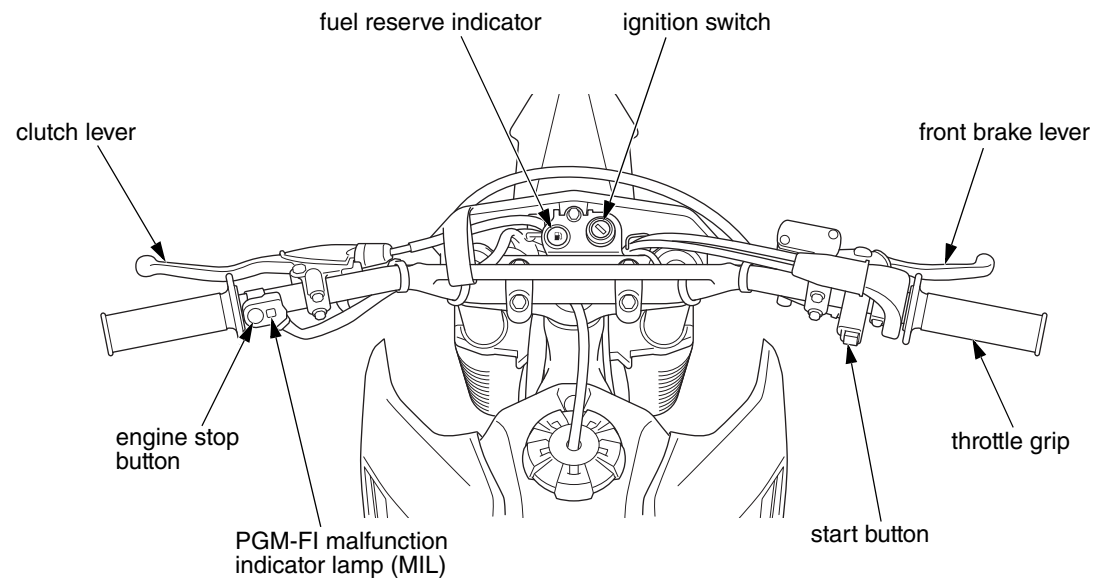

12 Operating Controls

Operation Component Locations

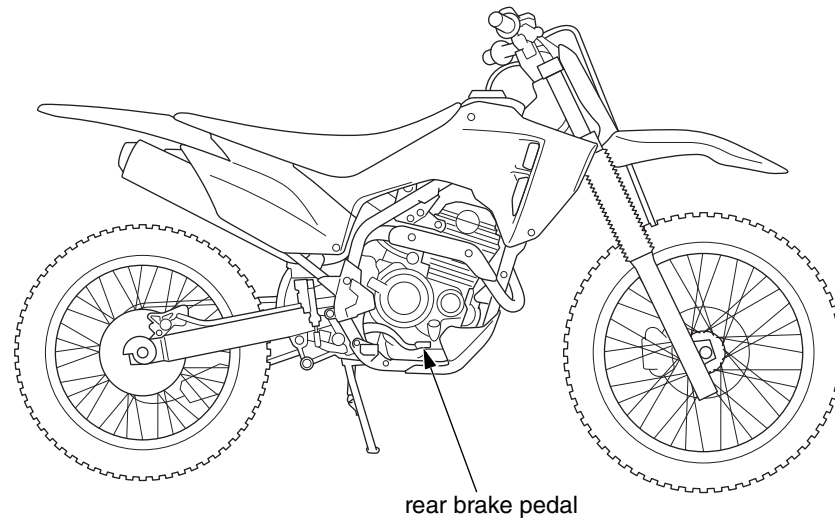

Operation Component Locations

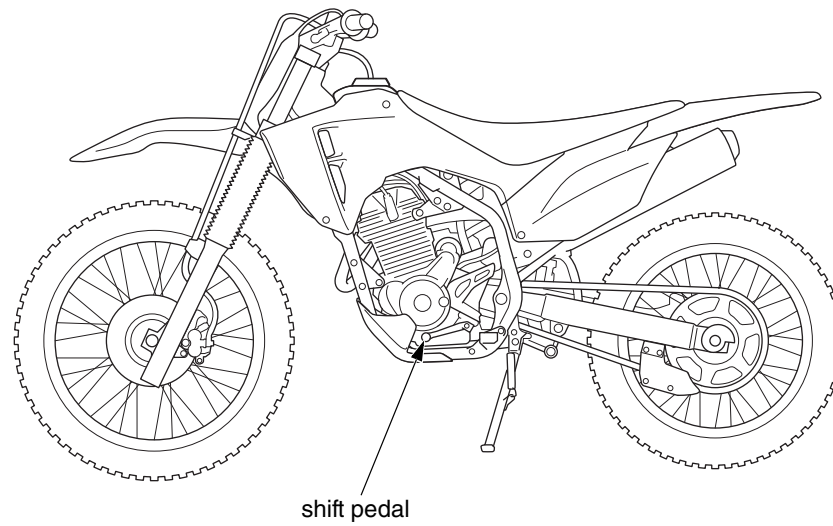

Operating Controls

Ignition Switch

The ignition switch (1) is used to prevent unauthorized use of the motorcycle.

Before riding, insert the key and turn it to the ● (ON) position.

Key Position	Function	Key Removal
OFF	The engine cannot be operated.	The key can be removed.
● (ON)	With the transmission in neutral or in gear with the clutch lever pulled in, the engine can be started.	The key cannot be removed.

After parking the motorcycle, remove the key.

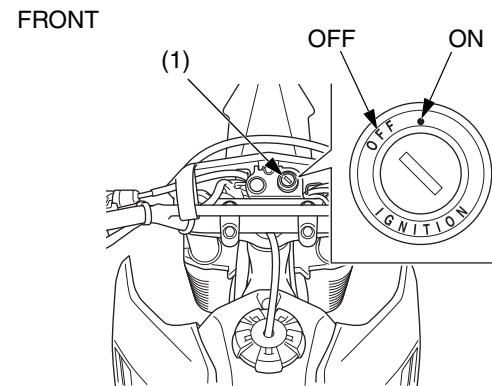

(1) ignition switch

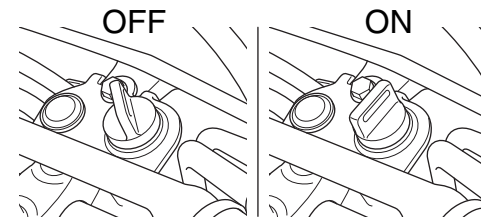

Operating Controls

Start Button



The start button is used for starting the engine. Pushing the button in starts the engine. See *Starting Procedure*, page 27.

When the start button is pushed, the starter motor will crank the engine.

Engine Stop Button

The engine stop button is used to turn the engine off in an emergency. To operate, push the button in and hold it in until the engine stops completely.

Front Brake Lever

The front brake lever is used to slow or stop your motorcycle. To operate, pull the lever. For information on braking techniques, see page 31.

Throttle

The throttle controls engine rpm (speed). To increase engine rpm, rotate the grip toward you. To reduce engine rpm, rotate the grip away from you. The throttle will automatically return to the closed position (engine idle) when you remove your hand.

Operating Controls

Clutch Lever

The clutch lever is used to disengage the clutch whenever you shift gears. To operate, pull the clutch lever in all the way before shifting, then slowly release it after shifting.

Shift Pedal

The shift pedal is used to select the next higher or lower gear in the transmission. To operate, raise the shift pedal (after pulling in the clutch lever) to engage the next higher gear or depress the shift pedal to engage the next lower gear. See *Shifting Gears*, page 29.

Rear Brake Pedal

The rear brake pedal is used to slow or stop your motorcycle. To operate, depress the pedal. For information on braking techniques, see page 31.

Side Stand

The side stand is used to support your motorcycle while parked (page 33). To operate, use your foot to lower the stand. Before riding, raise the stand. The side stand is only designed to support the weight of the motorcycle. Do not sit on the motorcycle with the side stand down where the side stand is supporting the weight of both the motorcycle and the rider. Do not use the side stand as a pivot to spin the motorcycle around. The side stand is directly mounted to the frame, so any misuse of the side stand will damage the frame.

Operating Controls

PGM-FI Malfunction Indicator Lamp (MIL)

Lights when there is any abnormality in the PGM-FI (Programmed Fuel Injection) system. The indicator should also light for a few seconds and then go off when the ignition switch is turned on. If the indicator does not come on when it should, have your dealer check for problems. If it comes on at any other time, reduce speed and take the motorcycle to your dealer as soon as possible.

Fuel Reserve Indicator



When this indicator comes on while riding, fuel reserved in the tank is about: 0.34 US gal (1.3 l).

The indicator should also light for a few seconds and then go off when the ignition switch is turned on. If the indicator does not come on when it should, have your dealer check for problems.

Before Riding

Before each ride, you need to make sure you and your Honda are both ready to ride. To help get you prepared, this section discusses how to evaluate your riding readiness, and how to perform the recommended pre-ride inspection of your Honda.

Are You Ready to Ride?	20
Protective Apparel	20
Is Your Motorcycle Ready to Ride?.....	22
Pre-ride Inspection	22

Are You Ready to Ride?

Before you ride your motorcycle for the first time, we strongly recommend that you:

- read this owner's manual
- make sure you understand all the safety messages
- know how to operate all the controls

Before each ride, we also suggest that you make sure you:

- are in good physical and mental condition
- are free of alcohol and drugs
- are wearing an approved motorcycle helmet (with chin strap tightened securely), eye protection, and other protective clothing

Protective Apparel

For your safety, we strongly recommend that you always wear an approved motorcycle helmet, eye protection, boots, gloves, long pants, and a long-sleeved jersey, shirt, or jacket whenever you ride. Although complete protection is not possible, wearing the proper gear can reduce the chance of injury when you ride. Following are suggestions to help you choose the proper gear.

Are You Ready to Ride?

⚠ WARNING

Not wearing a helmet increases the chance of serious injury or death in a crash.

Be sure you always wear a helmet, eye protection and other protective apparel when you ride.

Helmets and Eye Protection

Your helmet is your most important piece of riding gear because it offers the best protection against head injuries. A helmet should fit your head comfortably and have a chin strap that can be tightened securely.

An open-face helmet offers some protection, but a full-face helmet offers more. Regardless of the style, look for a DOT (Department of Transportation) sticker on any helmet you buy

(USA only). Always wear a face shield or goggles to protect your eyes and help your vision.

Additional Riding Gear

In addition to a helmet and eye protection, we also recommend:

- Sturdy off-road motorcycle boots to help protect your feet, ankles, and lower legs.
- Off-road motorcycle gloves to help protect your hands.
- Riding pants with knee and hip pads, a riding jersey with padded elbows, and a chest/shoulder protector.

Is Your Motorcycle Ready to Ride?

Before each ride, it's important to inspect your motorcycle and make sure any problem you find is corrected. A pre-ride inspection is a must because off-road riding can be tough on a motorcycle and you don't want to have a breakdown far from help.

⚠️ WARNING

Improperly maintaining this motorcycle or failing to correct a problem before riding can cause a crash in which you can be seriously hurt or killed.

Always perform a pre-ride inspection before every ride and correct any problems.

Pre-ride Inspection

Check the following items before you get on the motorcycle:

- | | |
|--------------------------|---|
| <i>Tires</i> | Use a gauge to check the air pressure. Adjust if needed. Also look for signs of damage or excessive wear (page 94). |
| <i>Spokes & Rims</i> | Make sure the spokes and rim locks are tight. Also check the rims for damage (page 88). |
| <i>Leaks</i> | Look under the motorcycle for signs of leaking fluids (fuel, engine oil, brake fluid). |

Is Your Motorcycle Ready to Ride?

Engine Oil Check the level and add oil if needed (page 60).

Fuel Check the level and add fuel (page 55) if needed. Also make sure the fuel fill cap is securely fastened.

Drive Chain Check the condition and slack. Adjust and lubricate if needed. Also check the chain slider, guide slider, and roller for wear and replace if needed (page 98).

Cables Check the cable housings for wear. Check the fittings for looseness. Replace or tighten as needed.

Nuts & Bolts Use a wrench to make sure all accessible nuts, bolts, and fasteners are tight.

Spark Plug & Cap Check for looseness (page 75).

Is Your Motorcycle Ready to Ride?

Check these items after you get on the motorcycle:

Throttle Check the freeplay and adjust if needed. Rotate the throttle to make sure it moves smoothly without sticking, and snaps shut automatically when it is released, in all steering positions (page 71).

Brakes Squeeze the front brake lever and step on the rear brake pedal to check that the controls operate normally (pages 82, 86). Check for proper adjustment (page 82).

Clutch Lever Check for smooth operation and adjust if needed (page 72).

Indicators Turn the ignition on and check for normal operation of the indicators (page 18).

Remember, be sure to take care of any problem you find or have your dealer correct it before you ride.

Basic Operation & Riding

This section gives basic information on how to begin riding your motorcycle. It includes how to start and stop your engine, how to use the throttle, clutch, and brakes, and what to do when you're through riding.

For more information on how to make turns, ride on hills, etc., see the *Tips & Practice Guide for the Off-Highway Motorcyclist* booklet that came with your Honda (USA only).

To protect your new engine and enjoy optimum performance and service life, refer to Break-in Guidelines (page 149).

Safe Riding Precautions	26
Starting & Stopping the Engine	27
Preparation	27
Starting Procedure.....	27
Flooded Engine	28
Bank Angle Sensor Ignition Cut-off System.....	28
How to Stop the Engine	28
Shifting Gears	29
Braking	31
Parking	33
Post-ride Inspection.....	34

Basic Operation & Riding

Safe Riding Precautions

Before riding your motorcycle for the first time, please review the *Important Safety Information* beginning on page 2 and the previous section, titled *Before Riding*.

Even if you have ridden other motorcycles, take time to become familiar with how this motorcycle works and handles. Practice in a safe area until you build up your skills and get accustomed to your motorcycle's size and weight.

For your safety, avoid starting or operating the engine in an enclosed area such as a garage. Your motorcycle's exhaust contains poisonous carbon monoxide gas which can collect rapidly in an enclosed area and cause illness or death.

⚠ WARNING

Running the engine of your vehicle while in an enclosed or even partially enclosed area can cause a rapid build-up of toxic carbon monoxide gas.

Breathing this colorless, odorless gas can quickly cause unconsciousness and lead to death.

Only run your vehicle's engine when it is located in a well ventilated area outdoors.

Your motorcycle is not equipped with lights. Do not ride at night.

Starting & Stopping the Engine

Always follow the proper starting procedure described below.

Your motorcycle can be started with the transmission in gear by pulling in the clutch lever before operating the starter.

Preparation

Before starting, insert the key and turn the ignition switch to ● (ON), and confirm the following:

- The transmission is in neutral.
- The PGM-FI malfunction indicator lamp (MIL) is off.

Starting Procedure

This motorcycle has a fuel-injected engine. Follow the procedure indicated below.

Any Air Temperature

1. With the throttle completely closed, press the start button.
2. If you cannot start the engine, open the throttle slightly (about 0.1 in (3 mm), without freeplay).

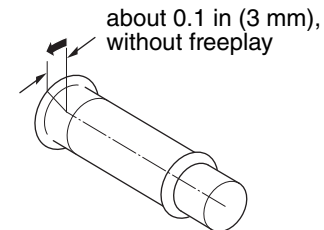

Starting & Stopping the Engine

Flooded Engine

If the engine fails to start after repeated attempts, it may be flooded with excess fuel. To clear a flooded engine:

1. Open the throttle fully.
2. While pushing the engine stop button, press the start button for 5 seconds.
3. Release the engine stop button.
4. Follow the normal engine starting procedure (page 27).

Bank Angle Sensor Ignition Cut-off System

Your motorcycle's banking (lean angle) sensor system is designed to automatically stop the engine and fuel pump if the motorcycle is overturned.

Before restarting the engine, you must turn the ignition switch to the OFF position and then back to ● (ON). The engine will not restart until you perform this procedure.

How to Stop the Engine

To stop the engine, shift into neutral, and turn the ignition switch to the OFF position.

Shifting Gears

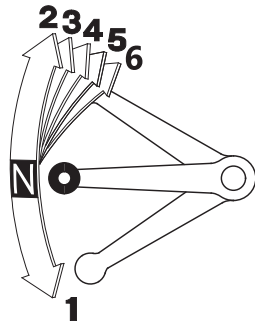

Your motorcycle has six forward gears.

To start riding, after the engine has been warmed and the side stand raised:

1. Close the throttle and pull the front brake lever in.
2. Pull the clutch lever all the way in.

3. Depress the shift pedal from neutral down to first gear.

4. Release the front brake. Gradually open the throttle while you slowly release the clutch lever.

If engine rpm (speed) is too low when you release the clutch lever, the engine will stall.

If engine rpm is too high or you release the clutch lever too quickly, your motorcycle may lurch forward.

5. When you attain a moderate speed, close the throttle, pull the clutch lever in, and raise the shift pedal. After shifting, release the clutch lever and apply the throttle.

(cont'd)

Shifting Gears

6. To continue shifting up to each higher gear, repeat step 5.
7. To shift down to a lower gear, close the throttle, pull the clutch lever in, and depress the shift pedal. After shifting, release the clutch lever and apply the throttle.

Remember to close the throttle and pull the clutch lever in completely before shifting.

NOTICE

Improper shifting may damage the engine, transmission, and drive train.

Learning when to shift gears comes with experience. Upshift to a higher gear or reduce throttle before engine rpm (speed) gets too high. Downshift to a lower gear before you feel the engine laboring (lugging) at low rpm.

NOTICE

Downshifting can help slow your motorcycle, especially on downhills. However, downshifting when engine rpm is too high can cause engine damage.

NOTICE

To prevent transmission damage, do not coast or tow the motorcycle for long distances with the engine off.

Braking

To slow or stop, apply the front brake and rear brake smoothly, while downshifting to match your speed. Gradually increase braking as you feel the brakes slowing your speed. To prevent stalling the engine, pull the clutch lever in before coming to a complete stop. For support, put your left foot down first, then your right foot when you have finished using the rear brake.

For maximum braking, close the throttle and firmly apply the brake lever and pedal controls.

Applying the brakes too hard may cause the wheels to lock and slide, reducing control of your motorcycle. If this happens, release the brake controls, steer straight ahead until you regain control, then reapply the brakes more gently.

Generally, reduce your speed or complete braking before beginning a turn. Avoid braking or closing the throttle quickly while turning. Either action may cause one or both wheels to slip. Any wheel slip will reduce your control of your motorcycle.

When riding in wet or rainy conditions, or on loose surfaces, the ability to maneuver and stop will be reduced. All of your actions should be smooth under these conditions. Rapid acceleration, braking or turning may cause loss of control. For your safety, exercise extreme caution when braking, accelerating, or turning.

Braking

When descending a long, steep grade, use engine compression braking by downshifting, with intermittent use of both brakes.

When you brake to a stop, pull the clutch lever in before stopping completely to prevent stalling the engine. For support, put your left foot on the ground first, then your right foot when you have finished braking.

Parking

Lower the side stand to support your motorcycle. Turn the ignition switch OFF and remove the key. Always choose a level place to park.

Post-ride Inspection

When you return home after riding, thoroughly clean your motorcycle and remove any dirt, mud, brush, rocks or other objects you may have picked up along the way.

After cleaning, carefully inspect your motorcycle for leaks or damage.

Be sure to lubricate the drive chain (page 103) to prevent rusting.

Servicing Your Honda

Keeping your motorcycle well maintained is absolutely essential to your safety. It's also a good way to protect your investment, get maximum performance, avoid breakdowns, and have more fun.

To help keep your motorcycle in good shape, this section includes a Maintenance Schedule for required servicing and step-by-step instructions for specific maintenance tasks. You'll also find important safety precautions, information on oils, and tips for keeping your Honda looking good.

For information about the exhaust emission and noise emission requirements of the U.S. Environmental Protection Agency (EPA), the California Air Resources Board (CARB), and Environment and Climate Change Canada (ECCC), see page 150.

For information about replacing fuse, see page 132.

An optional tool kit may be available. Check with your dealer's parts department.

USA only

Maintenance, replacement or repair of the emission control devices and systems may be performed by any motorcycle repair establishment or individual using parts that are "certified" to EPA standards.

Before You Service Your Honda

The Importance of Maintenance	37
Maintenance Safety	39
Important Safety Precautions	39
Maintenance Schedule	41
Maintenance Record	45
Competition Inspection	46

(cont'd)

Servicing Your Honda

Service Preparations

Maintenance Component Locations	49
Tools	52
Side Cover Removal	53

Service Procedures

Fluids & Filters

Fuel	54
Engine Oil	57
Air Cleaner	64
Crankcase Breather	68

Engine

Throttle	69
Clutch System	72
Spark Plug	75
Spark Arrester	77

Chassis

Suspension	79
Brakes	82
Wheels	87
Tires & Tubes	93
Side Stand	97
Drive Chain	98

Electrical

Battery	105
---------------	-----

Appearance Care	110
-----------------------	-----

The Importance of Maintenance

A well-maintained motorcycle is essential for safe, economical, and trouble-free riding. It will also help reduce air pollution. Careful pre-ride inspections and good maintenance are especially important because your motorcycle is designed to be ridden over rough off-road terrain.

To help you properly care for your motorcycle, this section of the manual provides a Maintenance Schedule. The service intervals in this schedule are based on average riding conditions.

More frequent service is needed if you subject your motorcycle to severe use (see the Competition Inspection checklist, page 46) or ride in unusually wet or dusty areas.

Frequent servicing of the air cleaner is especially important to help you avoid a possible costly engine repair.

If your motorcycle overturns or is involved in a crash, be sure your dealer inspects all major parts, even if you are able to make some repairs.

⚠ WARNING

Improperly maintaining this motorcycle or failing to correct a problem before you ride can cause a crash in which you can be seriously hurt or killed.

Always follow the inspection and maintenance recommendations and schedules in this owner's manual.

The Importance of Maintenance

Remember, proper maintenance is the owner's responsibility. Be sure to inspect your motorcycle before each ride and follow the Maintenance Schedule in this section.

Maintenance Safety

The maintenance section includes instructions on how to perform some important maintenance tasks. Some of the most important safety precautions follow. However, we cannot warn you of every conceivable hazard that can arise in performing maintenance. Only you can decide whether or not you should perform a given task.

⚠ WARNING

Failure to properly follow maintenance instructions and precautions can cause you to be seriously hurt or killed.

Always follow the procedures and precautions in this owner's manual.

Important Safety Precautions

- Make sure the engine is off before you begin any maintenance or repairs. This will help eliminate several potential hazards:

Carbon monoxide poisoning from engine exhaust. Be sure there is adequate ventilation whenever you operate the engine.

Burns from hot motorcycle parts. Let the engine and exhaust system cool before touching.

Injury from moving parts. Do not run the engine unless instructed to do so.

(cont'd)

Maintenance Safety

- Read the instructions before you begin, and make sure you have the tools and skills required.
 - To help prevent the motorcycle from falling over, park it on a firm, level surface, using the side stand or a maintenance stand to provide support.
 - To reduce the possibility of a fire or explosion, be careful when working around gasoline. Use only a non-flammable (high flash point) solvent such as kerosene – not gasoline – to clean parts. Keep cigarettes, sparks, and flames away from all fuel-related parts.
- Remember that your Honda dealer knows your motorcycle best and is fully equipped to maintain and repair it. To ensure the best quality and reliability, use only new Honda Genuine Parts or their equivalents for repair and replacement. If you have the tools and skills required for additional maintenance jobs, you can purchase an official Honda Service Manual (page 158).

Maintenance Schedule

To maintain the safety and reliability of your motorcycle, regular inspection and service is required as shown in the Maintenance Schedule that follows.

The Maintenance Schedule lists items that can be performed with basic mechanical skills and hand tools. Procedures for these items are provided in this manual.

The Maintenance Schedule also includes items that involve more extensive procedures and may require special training, tools, and equipment. Therefore, we recommend that you have your dealer perform these tasks unless you have advanced mechanical skills and the required tools. Procedures for items in this schedule are provided in a service manual available for purchase from your dealer (page 158).

Because your motorcycle does not have an odometer, service intervals in the maintenance schedules are expressed in terms of riding days as well as miles. To avoid overlooking required service, we urge you to develop a convenient way to record the number of days and/or miles you ride.

If you do not feel capable of performing a given task or need assistance, remember that your Honda dealer knows your motorcycle best and is fully equipped to maintain and repair it. If you decide to do your own maintenance, use only Honda Genuine Parts or their equivalents for repair or replacement to ensure the best quality and reliability.

Maintenance Schedule

Perform the pre-ride inspection (page 22) at each scheduled maintenance period.

Each item on the maintenance schedule requires some mechanical knowledge. Certain items (particularly those marked * and **) may require more technical information and tools. Consult your dealer.

* Should be serviced by your dealer, unless the owner has the proper tools and service data and is mechanically qualified. Refer to the official Honda Service Manual (page 158).

**In the interest of safety, we recommend these items be serviced only by your dealer.

Summary of Maintenance Schedule Notes and Procedures:

NOTES:

1. Service more frequently when ridden in wet or dusty conditions.
2. Replace every 2 years. Replacement requires mechanical skill.

Maintenance Procedures:

- I: inspect and clean, adjust, lubricate, or replace, if necessary
- C: clean
- A: adjust
- L: lubricate
- R: replace

Maintenance Schedule

Items	Frequency	Whichever Comes First		Initial Maint.	Regular Maint. Interval					Refer to page:
		⇒	mi	100	600	1,200	1,800	2,400		
			km	150	1,000	2,000	3,000	4,000		
Note	Month	1	6	12	18	24				
* Fuel Line						I		I	–	
** Fuel Filter				R: every 4,800 mi (8,000 km)					–	
* Throttle Operation						I		I	69	
Air Cleaner	Note 1			C	C	C	C	C	64	
Crankcase Breather				I	I	I	I	I	68	
Spark Plug				I	I	I	I	I	75	
* Valve Clearance				I	I	I	I	I	–	
Engine Oil				R	R	R	R	R	60	
Engine Oil Filter				R	R	R	R	R	62	
** Engine Idle Speed				I	I	I	I	I	–	

* Should be serviced by your dealer, unless the owner has the proper tools and service data and is mechanically qualified. Refer to the official Honda Service Manual (page 158).

** In the interest of safety, we recommend these items be serviced only by your dealer.

Maintenance Schedule

Items	Frequency	Which-ever Comes First ⇒	Initial Maint.	Regular Maint. Interval					Refer to page:
			mi	600	1,200	1,800	2,400		
			km	1,000	2,000	3,000	4,000		
Note	Month	1	6	12	18	24			
Drive Chain		Note 1	I, L	I, L: every 300 mi (500 km) or 3 months					98
Drive Chain Slider				I	I	I	I	I	99
Brake Fluid		Note 2		I	I	I	I	I	83
Brake Pads Wear				I	I	I	I	I	85
Brake System			I	I	I	I	I	I	82
Clutch System			I	I	I	I	I	I	72
Side Stand					I			I	97
* Suspension					I			I	79
* Spark Arrester			C: every 1,000 mi (1,600 km) or every 100 operating hours					77	
* Nuts, Bolts, Fasteners			I		I			I	–
** Wheels/Tires			I	I	I	I	I	I	87, 93
** Steering Head Bearings			I		I			I	–

* Should be serviced by your dealer, unless the owner has the proper tools and service data and is mechanically qualified. Refer to the official Honda Service Manual (page 158).

** In the interest of safety, we recommend these items be serviced only by your dealer.

Maintenance Record

Keeping an accurate maintenance record will help ensure that your motorcycle is properly maintained. Use the space under Notes to record anything you want to remind yourself about or mention to your dealer. Of course, if you find any problem while servicing your motorcycle, be sure it is corrected as soon as possible.

Miles (km) or Months	Date	Performed By:	Notes
600 (1,000) or 6			
1,200 (2,000) or 12			
1,800 (3,000) or 18			
2,400 (4,000) or 24			
3,000 (5,000) or 30			
3,600 (6,000) or 36			
4,200 (7,000) or 42			
4,800 (8,000) or 48			
5,400 (9,000) or 54			

Competition Inspection

All items should be checked before each competition event. See your dealer unless you are mechanically qualified and have the proper tools.

Damage from competition use is not covered by the Distributor's Limited Warranty on your Honda.

NOTE: Refer to the Maintenance Schedule (page 42) for regular service intervals.

No	Item	Inspect For:	Action	Refer to Page:
1	all pre-ride inspection items			22
2	engine oil	contaminants	change	60
3	fuel line	deterioration, damage, or leakage	replace	–
4	valve clearance	correct clearance	adjust	–

Competition Inspection

No	Item	Inspect For:	Action	Refer to Page:
5	clutch discs	proper operation, see NOTE 1	replace	–
6	air cleaner	contamination or tears	clean or replace	64
7	spark plug	gap, tightness, proper heat range, high-tension terminal security	tighten, replace or secure	75
8	steering head bearings	free rotation of handlebar and steering stem nut tightness	adjust or retighten	–
9	front suspension	smooth operation, oil capacity, no oil leaks, good boot condition	replace or adjust	79
10	rear suspension	smooth operation, no oil leaks	replace or adjust	80

NOTE 1: Competition use may cause more rapid clutch disc wear. Refer to the official Honda Service Manual, or see your dealer for clutch disassembly and wear inspection.

Competition Inspection

No	Item	Inspect For:	Action	Refer to Page:
11	swingarm bearings	smooth operation	replace	80
12	rear suspension linkage bearings	smooth operation and secure installation	replace or tighten	80
13	brake pads	wear beyond service limit	replace	85
14	drive chain: max. length/pin	25.1 in (638 mm) / 41 pins	replace	100
15	sprockets	wear and secure installation	replace or tighten	101
16	seat	security	tighten	–
17	control cables	smooth operation, kinks and correct routing	lubricate or replace	–
18	engine mounting bolts	tightness	tighten	–

Maintenance Component Locations

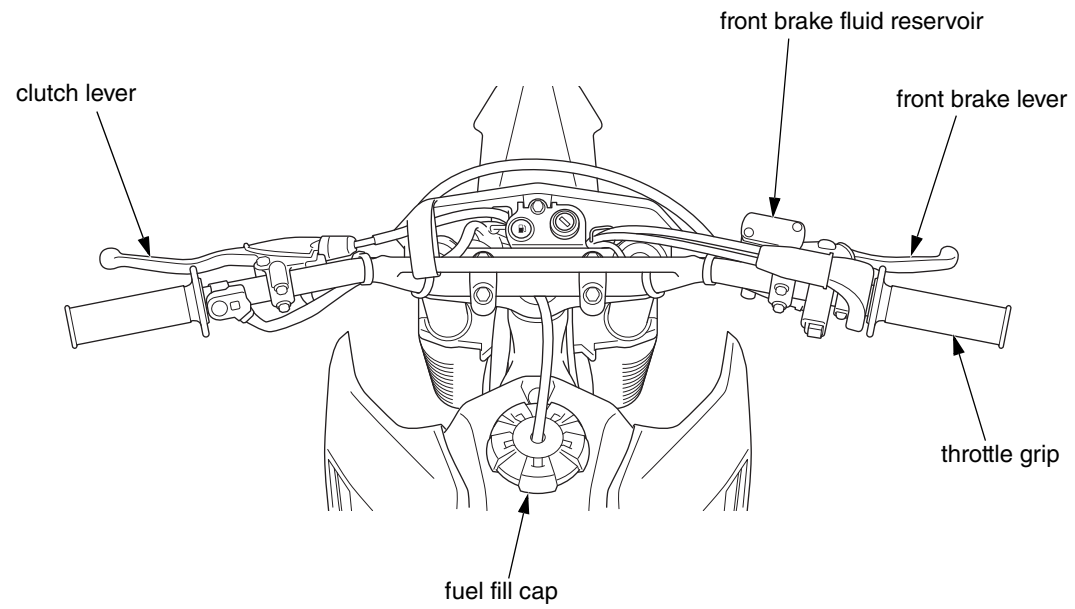

Maintenance Component Locations

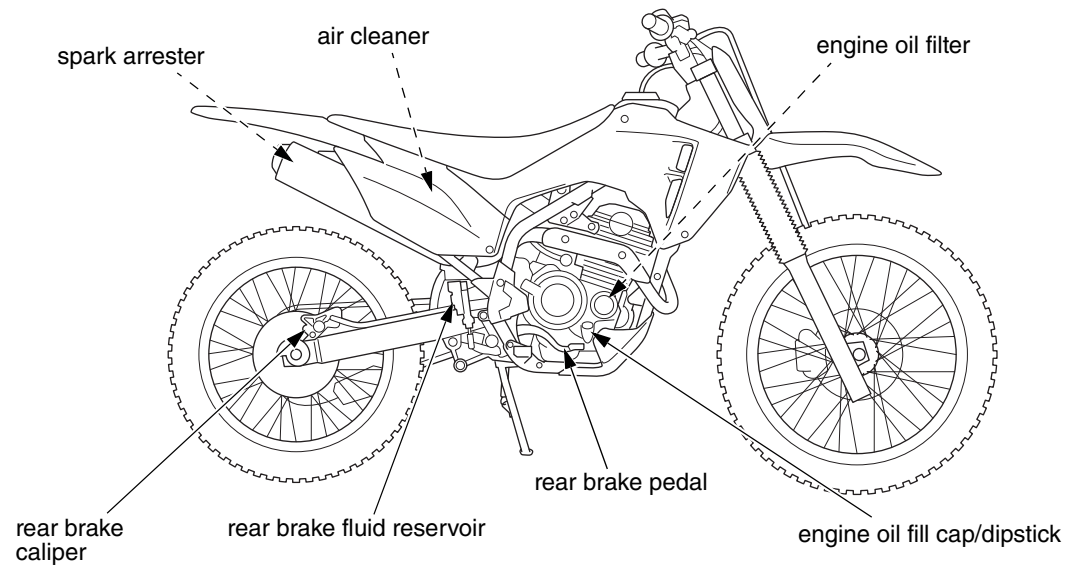

Maintenance Component Locations

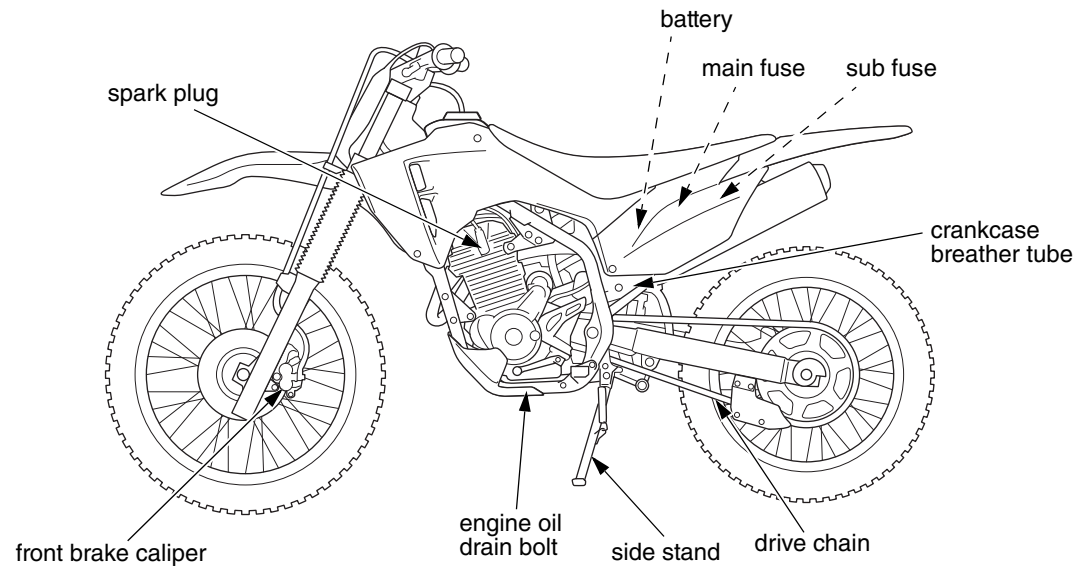

Tools

Refer to *Safety Precautions* on page 39.

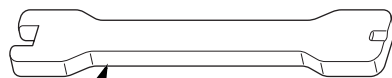

(1)

(1) spoke wrench

The spoke wrench is delivered with your motorcycle for tightening or loosening the spokes (USA only).

You will need to provide your own tools to perform any owner maintenance.

Side Cover Removal

Refer to *Safety Precautions* on page 39.

RIGHT SIDE

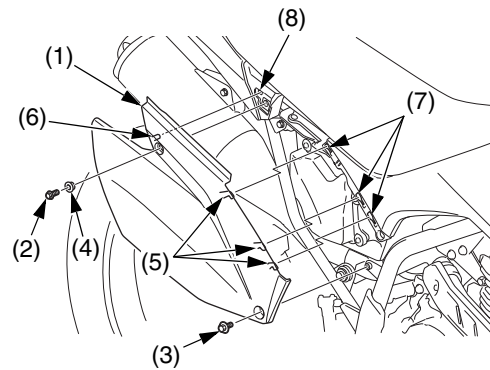

(1) right side cover
(2) bolt A
(3) bolt B
(4) collar

(5) hooks
(6) prong
(7) guides
(8) hole

The right and left side covers can be removed in the same manner.

The right side cover (1) must be removed to service the air cleaner.

The left side cover must be removed to service the battery, main fuse and sub fuse.

Removal

1. Remove the bolt A (2) and bolt B (3).
2. Pull out the prong (6) from the hole on the rear fender.
3. Slide the side cover in a backward direction and pull out the hooks (5) from the guides (7).

Installation

1. Slide the top of the side cover under the bottom edge of the seat.
2. Align the hooks (5) with the guides (7) and slide the side cover in a forward direction.
3. Align the prong (6) with the hole (8) on the rear fender.
4. Install the bolt and tighten it securely.

Fuel

Refer to *Safety Precautions* on page 39.

Fuel Recommendation

Type	unleaded
Pump Octane Number	86 (or higher)

Your engine is designed to use any unleaded gasoline that has a pump octane number of 86 or higher. Gasoline pumps at service stations normally display the pump octane number. For information on the use of oxygenated fuels, see page 155.

Use of lower octane gasoline can cause persistent “pinging” or “spark knock” (a louder rapping noise) which, if severe, can lead to engine damage. (Light pinging experienced while operating under a heavy load, such as climbing a hill, is no cause for concern.)

If pinging or spark knock occurs at a steady engine speed under normal load, change brands of gasoline. If pinging or spark knock persists, consult your dealer.

Use only unleaded fuel in your Honda. If you ride your Honda in a country where leaded fuel might be available, take precautions to use only unleaded fuel.

Never use stale or contaminated gasoline or an oil/gasoline mixture. Avoid getting dirt, dust, or water in the fuel tank.

Fuel

Refueling Procedure

Fuel Tank Capacity, including reserve:
1.6 US gal (6 ℓ)

Reserve Capacity:
0.34 US gal (1.3 ℓ)

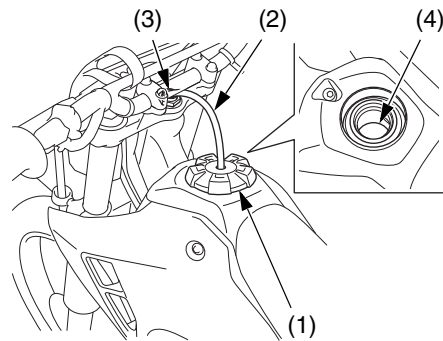

(1) fuel fill cap
(2) breather tube
(3) steering stem nut
(4) bottom of the filler neck

1. To open the fuel fill cap (1), pull the breather tube (2) out of the steering stem nut (3). Turn the fuel fill cap counterclockwise and remove it.
2. Add fuel until the level reaches the bottom of the filler neck (4). Avoid overfilling the tank. There should be no fuel in the filler neck.

⚠ WARNING

Gasoline is highly flammable and explosive. You can be burned or seriously injured when handling fuel.

- Stop the engine and keep heat, sparks and flame away.
- Handle fuel only outdoors.
- Wipe up spills immediately.

(cont'd)

Fuel

3. After refueling, turn the fuel fill cap clockwise until it clicks.
4. Insert the breather tube in the steering stem nut.

If you replace the fuel fill cap, use a Honda Genuine replacement part or equivalent.

Engine Oil

Refer to *Safety Precautions* on page 39.

Using the proper oil, and regularly checking, adding, and changing oil will help extend your engine's life. Even the best oil wears out. Changing oil helps get rid of dirt and deposits held in the engine. Operating the engine with old or dirty oil can damage your engine. Running the engine with insufficient oil can cause serious damage to the engine and transmission.

Oil Recommendation

API classification	SJ or higher except oils labeled as energy conserving or resource conserving on the circular API service label
viscosity (weight)	SAE 10W-30*
JASO T 903 standard	MA
suggested oil**	Pro Honda GN4 4-stroke oil (USA & Canada), or Honda 4-stroke oil, or an equivalent motorcycle oil

Engine Oil

- * For normal air temperatures. See next page for additional temperature/viscosity information.
- **Suggested oils are equal in performance to SJ oils that are not labeled as energy conserving or resource conserving on the circular API service label.

- Your motorcycle does not need oil additives. Use the recommended oil.
- Do not use oils with graphite or molybdenum additives. They may adversely affect clutch operation.
- Do not use API SH or higher oils displaying a circular API “energy conserving” or “resource conserving” service label on the container. They may affect lubrication and clutch performance.

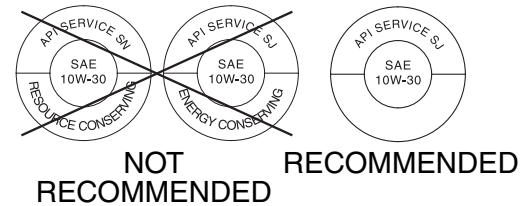

- Do not use non-detergent, vegetable, or castor based racing oils.

Engine Oil

Other viscosities shown in the following chart may be used when the average temperature in your riding area is within the indicated range.

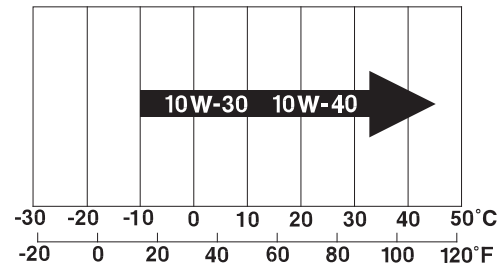

JASO T 903 standard

The JASO T 903 standard is an index for engine oils for 4-stroke motorcycle engines.

There are two classes: MA and MB.

Oil conforming to the standard is labeled on the oil container. For example, the following label shows the MA classification.

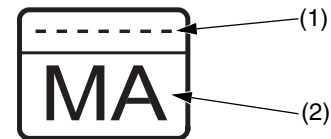

- (1) oil code
- (2) oil classification

Engine Oil

Checking & Adding Oil

RIGHT SIDE

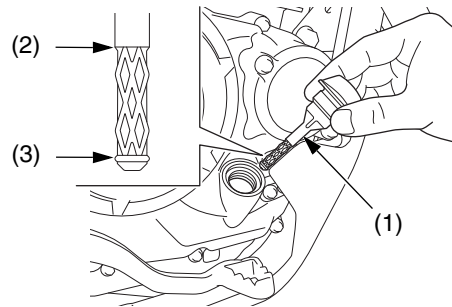

(1) oil fill cap/dipstick
(2) upper level mark
(3) lower level mark

1. Park your motorcycle on a firm, level surface.
2. Clean around the oil fill cap/dipstick (1) and nearby surfaces.

3. Start the engine and let it idle for 3-5 minutes. Stop the engine. Wait 2-3 minutes.
4. Unscrew and remove the oil fill cap/dipstick. Wipe it clean.
5. Hold the motorcycle upright.
6. Insert the oil fill cap/dipstick until it seats, but do not screw it in.
7. Remove the oil fill cap/dipstick and check the oil level.
 - If the oil is at or near the upper level mark (2), you do not have to add oil.
 - If the oil is below or near the lower level mark (3), add the recommended oil until it reaches the upper level mark. (Do not overfill.)
8. Insert the oil fill cap/dipstick and screw it in tightly.
9. Check for oil leaks.

Engine Oil

Changing Engine Oil

UNDER ENGINE

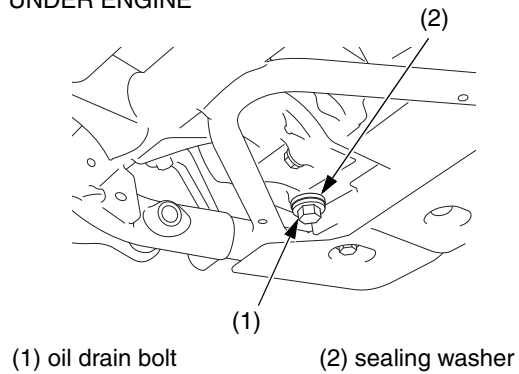

1. If the engine is cold, start it and let it idle for 3-5 minutes. Turn the engine off. Wait 2-3 minutes for the oil to settle.
2. Park your motorcycle on its side stand on a firm, level surface.
3. Place a drain pan under the crankcase.
4. To drain the oil, remove the oil fill cap/ dipstick, oil drain bolt (1) and sealing washer (2).

(cont'd)

Engine Oil

RIGHT SIDE

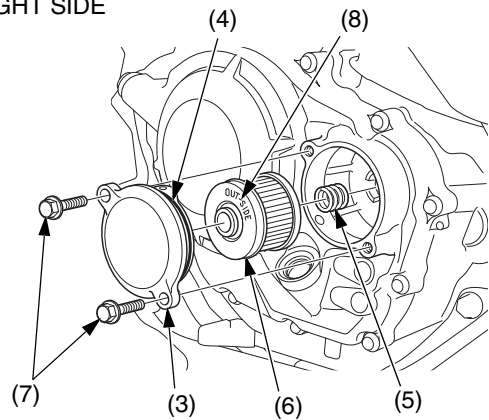

- | | |
|----------------------|----------------------------|
| (3) oil filter cover | (6) oil filter |
| (4) O-ring | (7) oil filter cover bolts |
| (5) spring | (8) "OUT-SIDE" mark |

5. Remove the oil filter cover (3)/O-ring (4), spring (5) and oil filter (6) by removing the oil filter cover bolts (7).

6. Pour the drained oil into suitable container and dispose of it in an approved manner (page 123).

NOTICE

Improper disposal of drained fluids is harmful to the environment.

7. Install the spring, and then install a new oil filter with the "OUT-SIDE" mark (8) facing out. Use only the Honda Genuine oil filter or a filter of equivalent quality specified for your model. Using the wrong Honda filter or a non-Honda filter which is not of equivalent quality may cause engine damage.

NOTICE

Improper installation of the oil filter can cause serious engine damage.

Engine Oil

8. Replace the O-ring and apply a thin coat of engine oil to the new O-ring before installing it.
9. Install the oil filter cover/O-ring and oil filter cover bolts. Tighten the bolts to the specified torque:
9 lbf·ft (12 N·m, 1.2 kgf·m)
10. Install a new sealing washer onto the drain bolt.
11. Tighten the oil drain bolt to the specified torque:
18 lbf·ft (24 N·m, 2.4 kgf·m)
12. Pour the recommended oil into the crankcase.
If the oil filter was replaced:
1.7 US qt (1.6 ℓ)
If the oil filter was not replaced, use approximately:
1.6 US qt (1.5 ℓ)
13. Install the oil fill cap/dipstick securely.
14. Start the engine and let it idle for 3-5 minutes. Stop the engine. Wait 2-3 minutes.
15. With the motorcycle held upright on level ground, check the oil level.
If needed, add oil (page 60) until it reaches the upper level mark. (Do not overfill.)
16. Check for oil leaks.

Air Cleaner

Refer to *Safety Precautions* on page 39.

Proper air cleaner maintenance is very important for off-road vehicles. A dirty, water-soaked, worn-out, or defective air cleaner will allow dirt, dust, mud, and other impurities to pass into the engine.

Service the air cleaner more frequently if you ride in unusually wet or dusty areas. Your dealer can help you determine the correct service interval for your riding conditions.

Your motorcycle's air cleaner has very specific performance requirements. Use a new Honda Genuine air cleaner specified for your model or an air cleaner of equal quality.

NOTICE

Using the wrong air cleaner may result in premature engine wear.

Proper air cleaner maintenance can prevent premature engine wear or damage, expensive repairs, low engine power, poor gas mileage, and spark plug fouling.

NOTICE

Improper or lack of proper air cleaner maintenance can cause poor performance and premature engine wear.

Air Cleaner

Cleaning

RIGHT SIDE

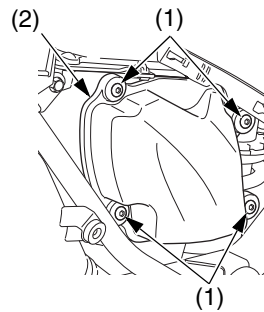

(1) screws
(2) air cleaner housing cover

1. Remove the right side cover (page 53).
2. Remove the screws (1) and air cleaner housing cover (2).

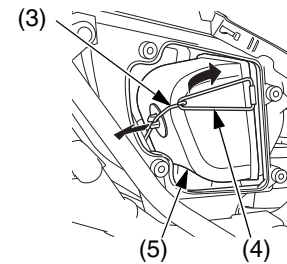

(3) set spring
(4) set spring holder
(5) air cleaner

3. Unhook the set spring (3), take care to avoid bending the set spring and set spring holder (4).
4. Remove the air cleaner (5).

(cont'd)

Air Cleaner

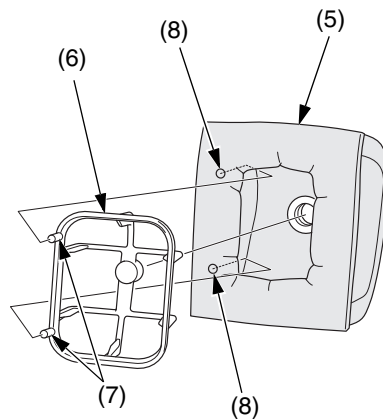

(5) air cleaner
(6) air cleaner holder
(7) tabs
(8) air cleaner holes

5. Remove the air cleaner holder (6) from the air cleaner (5).
6. Gently wash the air cleaner in clean, non-flammable (high flash point) solvent such as kerosene – not gasoline. After cleaning, gently squeeze out the remaining solvent. Avoid twisting or wringing the air cleaner. This can tear the foam.
7. Inspect for tears or cracks in the foam or seams of the air cleaner. Replace the air cleaner if it is damaged.
8. Allow the air cleaner to dry thoroughly before applying oil. A wet air cleaner will not fully absorb the oil.

Air Cleaner

9. Pour clean Pro Honda Foam Filter Oil or an equivalent (Canada: Honda Foam Filter Oil or an equivalent) over the entire surface of the air cleaner. Use both hands to evenly spread the oil into the air cleaner. Gently squeeze out any excess oil. (To keep your hands dry, place the air cleaner in a clean plastic bag before spreading the oil into the air cleaner.)
10. Assemble the air cleaner and holder.
Insert the tabs (7) in the air cleaner holes (8).
11. Clean the inside of the air cleaner housing.
12. Apply a thin coat of grease to the sealing surface of the air cleaner.
13. Install the air cleaner assembly by inserting the tabs (9) on the air cleaner holder into the holes (10) in the air cleaner housing.
Hook the set spring.
Check that the air cleaner is properly seated.

14. Install the air cleaner housing cover and screws.
4 lbf·ft (5 N·m, 0.5 kgf·m)
15. Install the right side cover (page 53).

RIGHT SIDE

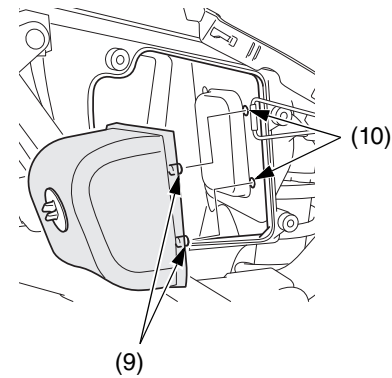

(9) tabs

(10) holes

Crankcase Breather

Refer to *Safety Precautions* on page 39.

Service more frequently if your motorcycle is ridden in the rain or often at full throttle, or after the motorcycle is washed or overturned.

LEFT SIDE

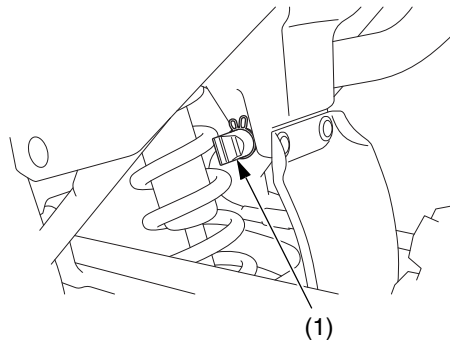

(1) crankcase breather tube

If the drain tube overflows, the air filter may become contaminated with engine oil causing poor engine performance.

1. Place a suitable container under the crankcase breather tube.
2. Drain the deposits into a suitable container by pinching the crankcase breather tube (1).

Throttle

Refer to *Safety Precautions* on page 39.

Throttle Freeplay

RIGHT SIDE

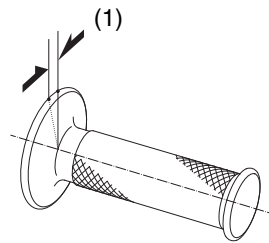

(1) freeplay

Inspection

Check freeplay (1).

Freeplay: 1/16 – 1/4 in (2 – 6 mm)

If necessary, adjust to the specified range.

Upper Adjustment

Minor adjustments are generally made with the upper adjuster.

RIGHT SIDE

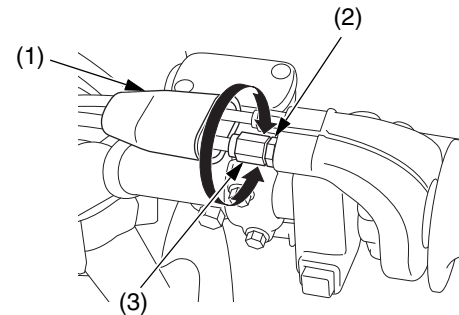

(1) rubber dust cover (3) upper adjuster
(2) upper lock nut

1. Pull the rubber dust cover (1) back.
2. Loosen the upper lock nut (2) on the throttle cable mechanism.
3. Turn the upper adjuster (3).

(cont'd)

Throttle

4. Tighten the lock nut. Return the dust cover to its normal position.
5. After adjustment, check for smooth rotation of the throttle grip from fully closed to fully open in all steering positions.

Lower Adjustment

The lower adjuster is used for major freeplay adjustment, such as after replacing the throttle cables or removing the throttle body. It is also used if you cannot get the proper adjustment with the upper adjuster.

LEFT SIDE

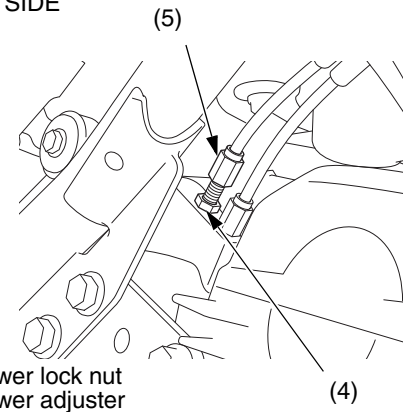

(4) lower lock nut
(5) lower adjuster

1. Loosen the lower lock nut (4).
2. Turn the lower adjuster (5).
3. Tighten the lock nut.

If you can't get the freeplay within the specified range, contact your dealer.

Throttle

Throttle Inspection

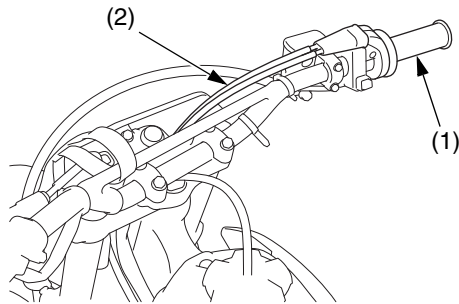

- (1) throttle
- (2) throttle cables

1. Check that the throttle assembly is positioned properly, and the securing bolts are tight.
2. Check for smooth rotation of the throttle (1) from fully open to fully closed in all steering positions. If there is a problem, see your dealer.

3. Inspect the condition of the throttle cables (2) from the throttle grip down to the throttle body. If the cable is kinked or chafed, have it replaced.
4. Check the cables for tension or stress in all steering positions.
5. Lubricate the cables with a commercially available cable lubricant to prevent premature rust and corrosion.

Clutch System

Refer to *Safety Precautions* on page 39.

Clutch Freeplay

LEFT SIDE

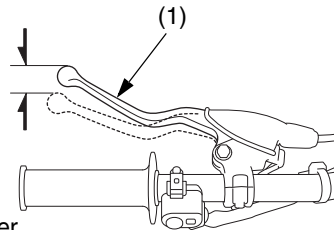

(1) clutch lever

Inspection

Check freeplay.

Freeplay: 3/8 – 13/16 in (10 – 20 mm)

If necessary, adjust to the specified range.

Improper freeplay adjustment can cause premature clutch wear.

Upper Adjustment

Minor adjustments are generally made with the upper clutch cable adjuster.

Upper clutch assembly adjuster:

LEFT SIDE

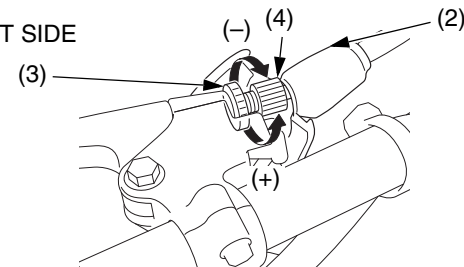

(2) rubber dust cover (+) increase freeplay
(3) upper lock nut (-) decrease freeplay
(4) upper clutch cable adjuster

1. Pull the rubber dust cover (2) off.
2. Loosen the upper lock nut (3).
3. Turn the upper clutch cable adjuster (4) to obtain the specified freeplay.

Clutch System

4. Tighten the lock nut and check the freeplay again.
5. Return the dust cover to its normal position.

Lower Adjustment

The lower clutch cable adjuster is used if the upper clutch cable adjuster is threaded out near its limit, or the correct freeplay cannot be obtained.

1. Loosen the upper lock nut (3) and turn the upper clutch cable adjuster (4) all the way in (to provide maximum freeplay).
2. Tighten the upper lock nut and pull the rubber dust cover (2) back to its normal position.
3. Pull the cable boot (5) off the clutch cable lower adjuster (6).
4. Hold the lower clutch cable adjuster and loosen the lock nut (7).

RIGHT SIDE

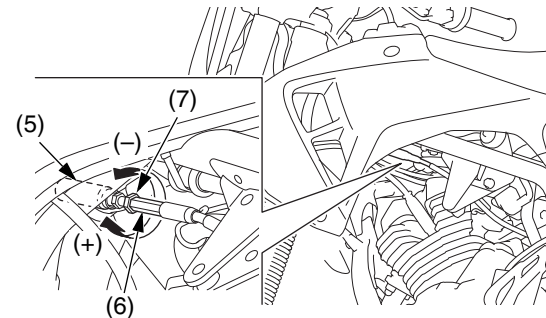

- (5) cable boot
(6) lower adjuster
(7) lock nut
- (+) increase freeplay
(-) decrease freeplay

5. Turn the clutch cable lower adjuster to obtain the specified freeplay. Hold the lower clutch cable adjuster and tighten the lock nut. Return the cable boot to its normal position. Check the clutch lever freeplay.

(cont'd)

Clutch System

6. Start the engine, pull the clutch lever in, and shift into gear. Make sure the engine does not stall and the motorcycle does not creep. Gradually release the clutch lever and open the throttle. Your motorcycle should move smoothly and accelerate gradually.

If you can't get proper adjustment, or the clutch does not work properly, the cable may be kinked or worn, or the clutch discs may be worn. See your dealer or refer to the official Honda Service Manual (page 158).

Other Inspections & Lubrication

- Check that the clutch lever assembly is positioned properly, and the securing bolts are tight.
- Check the clutch cable for kinks or signs of wear. If necessary, have it replaced.
- Lubricate the clutch cable with a commercially available cable lubricant to prevent premature wear and corrosion.

Spark Plug

Refer to *Safety Precautions* on page 39.

Spark Plug Recommendation

The recommended standard spark plug is satisfactory for most riding conditions.

Standard	SILMAR7D9DS (NGK)
----------	-------------------

Use only the recommended type of spark plugs in the recommended heat range.

NOTICE

Using spark plugs with an improper heat range can cause engine damage.

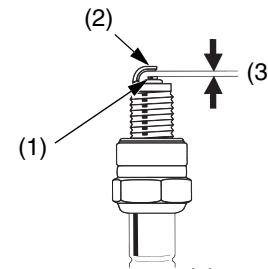

(1) center electrode
(2) side electrode

(3) spark plug gap

1. Clean any dirt from around the spark plug base.
2. Disconnect the spark plug cap.
3. Using a spark plug wrench, remove the spark plug.

(cont'd)

Spark Plug

4. Inspect the spark plug electrodes for wear. The center electrode (1) should have square edges. The side electrode (2) should not be eroded. The insulator should not be cracked or chipped.
5. Check the spark plug gap (3), using a wire-type feeler gauge. If adjustment is necessary, bend the side electrode carefully. The gap should be:
0.03 – 0.04 in (0.8 – 0.9 mm)
Make sure the plug washer is in good condition.
If you have to install a new plug, first check the gap.
6. With the plug washer attached, thread the spark plug in by hand (to prevent cross-threading).
7. Tighten the spark plug:
 - If the old plug is good:
 - 1/5 turn after it seats.
 - If installing a new plug, tighten it twice to prevent loosening:
 - a) First, tighten the plug:
 - 1/4 turn after it seats.
 - b) Then loosen the plug.
 - c) Next, tighten the plug again:
 - 1/5 turn after it seats.
8. Reinstall the spark plug cap. Take care to avoid pinching any cables or wires.

NOTICE

An improperly tightened spark plug can damage the engine. If a plug is too loose, a piston may be damaged. If a plug is too tight, the threads may be damaged.

Spark Arrester

Refer to *Safety Precautions* on page 39.

The spark arrester must be serviced every 100 operating hours to maintain its efficiency.

Regular servicing prevents carbon buildup (which can diminish engine performance) and also complies with USDA regulations for regular maintenance to assure proper function. The spark arrester prevents random sparks from the combustion process in your engine from reaching the environment.

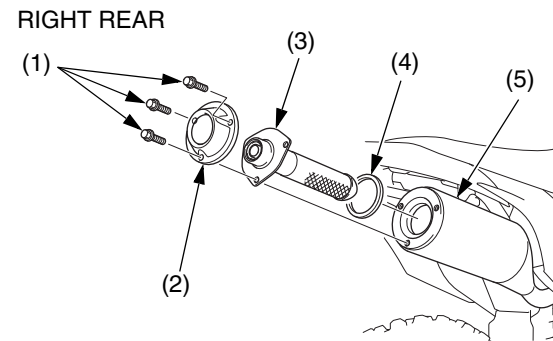

- (1) bolts
- (2) tail cover
- (3) spark arrester
- (4) gasket
- (5) muffler

1. Allow the engine and muffler to cool.
2. Remove the bolts (1) and tail cover (2), the spark arrester (3), and the gasket (4) from the muffler (5).

(cont'd)

Spark Arrester

3. Use a brush to remove carbon deposits from the spark arrester screen (6). Be careful to avoid damaging the spark arrester screen. The spark arrester must be free of breaks and holes. Replace, if necessary.

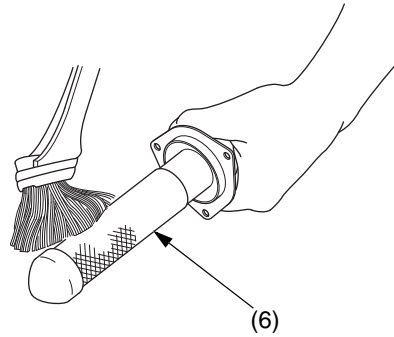

(6) spark arrester screen

4. Install the new gasket, the spark arrester and tail cover, and tighten the bolts to the specified torque:
9 lbf·ft (12 N·m, 1.2 kgf·m)

Suspension

Refer to *Safety Precautions* on page 39.

Loose, worn, or damaged suspension components may adversely affect the handling and stability of your motorcycle. If any suspension components appear worn or damaged, see your dealer for further inspection. Your dealer is qualified to determine whether or not replacement parts or repairs are needed.

Front Suspension Inspection

1. Check fork operation. Pull the front brake lever in, to lock the brake. Then pump up and down on the fork legs several times. The suspension should function smoothly. There should be no oil leakage.

FRONT

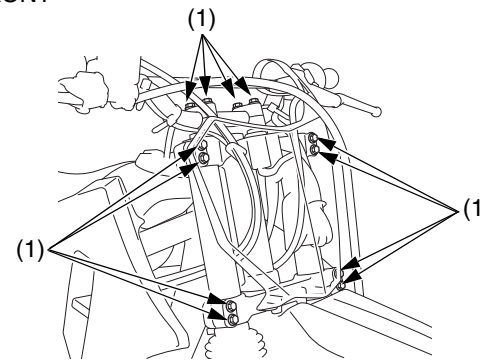

(1) mounting bolts

2. Check the security of all handlebar and fork mounting bolts (1). If any front suspension components appear worn or damaged, see your dealer for further inspection.

Suspension

Rear Suspension Inspection

RIGHT SIDE

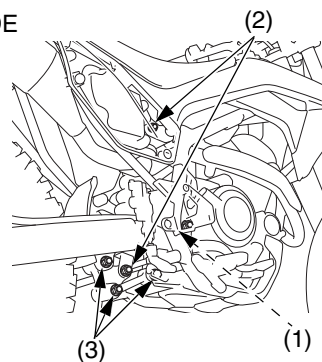

- (1) swingarm bearing
- (2) shock absorber attachment points
- (3) suspension linkage attachment points

LEFT SIDE

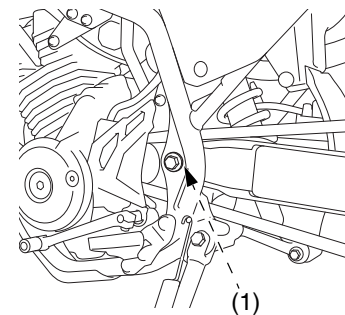

(1) swingarm bearing

1. Place the motorcycle on a maintenance stand. Push hard against the side of the rear wheel and feel for any freeplay which indicates worn swingarm bearings (1).

Suspension

2. Check that the fasteners for the shock absorber attachment points (2) and rear suspension linkage attachment points (3) are secure.
3. Check for oil leaks in the shock absorber. If any rear suspension components appear worn or damaged, see your dealer for further inspection.

Brakes

Refer to *Safety Precautions* on page 39.

The front brake is the hydraulic disc type. As the brake pads wear, the brake fluid level will drop. A leak in the system will also cause the level to drop.

Frequently inspect the system to ensure there are no fluid leaks. Periodically inspect the brake fluid level and the brake pads for wear.

If the front brake lever or brake pedal freeplay does not feel within the normal range while riding, check the brake pads. If they are not worn beyond the recommended limit (page 85), there is probably air in the brake system. See your dealer to have the air bled from the system.

Front Brake Lever Adjustment

RIGHT HANDLEBAR

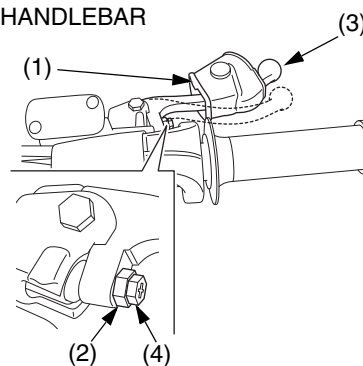

- (1) rubber dust cover
- (2) lock nut
- (3) front brake lever
- (4) adjuster

Never use adjusters other than those designed for this motorcycle. Install a new adjuster from the lever side with the lock nut under the head of the adjuster.

Brakes

1. Pull the rubber dust cover (1) back.
2. Loosen the lock nut (2).
3. To position the front brake lever (3) farther away from the handgrip, turn the adjuster (4) clockwise.
To position the front brake lever closer to the handgrip, turn the adjuster counterclockwise.
4. Tighten the lock nut. Return the dust cover to its normal position.
5. Apply the brake, release it, then spin the wheel and check that it rotates freely. Repeat this procedure several times.

Fluid Level Inspection

Front Brake Fluid Level

RIGHT
HANDLEBAR

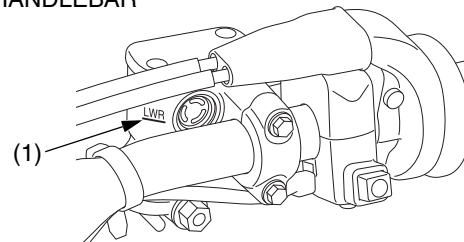

(1) LWR mark

With the motorcycle in an upright position, check the fluid level. It should be above the LWR mark (1). If the level is at or below the LWR mark, check the brake pads for wear (page 85).

Brakes

Rear Brake Fluid Level

RIGHT SIDE

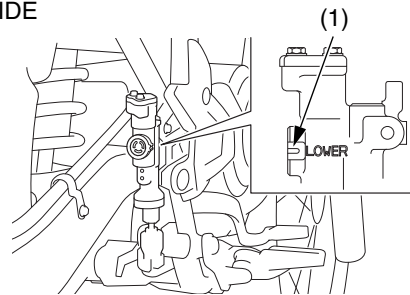

(1) LOWER mark

With the motorcycle in an upright position, check the fluid level.

It should be above the LOWER mark (1). If the level is at or below the LOWER mark, check the brake pads for wear.

Worn brake pads should be replaced. If the pads are not worn, have your brake system inspected for leaks.

The recommended brake fluid is Honda DOT 4 brake fluid from a sealed container, or an equivalent.

NOTICE

Brake fluid can damage plastic and painted surfaces. Handle with care.

Wipe up spills immediately. Avoid brake fluid contact with skin or eyes. If it comes in contact with your eyes, wash them out with clean water and immediately call a doctor. If it comes in contact with your skin, wash with clean water and, if necessary, call a doctor.

Other Inspections

- Make sure there are no fluid leaks.
- Check for deterioration or cracks in the hoses and fittings.

Brakes

Brake Pad Wear

Brake pad wear depends on the severity of usage, the type of riding, and riding area conditions. (Generally, the pads will wear faster on wet and dirty riding terrain.) Inspect the pads at each regular maintenance interval (page 44).

Check the cutouts (2) in each pad. If either pad is worn to the cutout, replace both pads as a set. See your dealer for this service.

LEFT FRONT

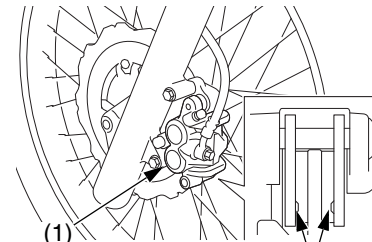

(1) front brake caliper
(2) cutouts

RIGHT REAR

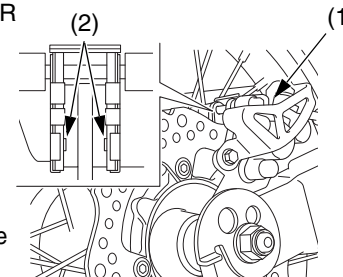

(1) rear brake caliper
(2) cutouts

Brakes

Other Inspections

Check that the front lever and rear brake pedal assembly are positioned properly, and the securing bolts are tight.

More About: Brake Fluid

Brake fluid should be added and replaced by your dealer.

The recommended brake fluid is Honda DOT 4 Brake Fluid, or any brake fluid of equal quality and performance. Use fresh brake fluid from a sealed container.

Wheels

Refer to *Safety Precautions* on page 39.

Keeping the wheels true (round) and maintaining correct spoke tension is critical to safe motorcycle operation. During the first 100 miles (150 km), spokes will loosen more rapidly due to the initial seating of the parts. Excessively loose spokes may result in instability at high speeds and the possible loss of control. Neglecting this maintenance may also cause rim or spoke damage. It's also important that the rim locks are secure to prevent tire slippage.

It is not necessary to remove the wheels to perform the recommended service in the Maintenance Schedule. However, information for wheel removal is provided for emergency situations.

Wheels

Wheel Rims & Spokes

REAR

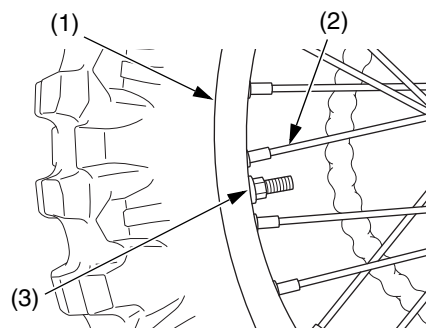

- (1) wheel rim
- (2) spoke
- (3) rim lock

1. Inspect the wheel rims (1) and spokes (2) for damage.
2. Tighten any loose spokes or rim locks (3).
3. Rotate the wheel slowly to see if it appears to “wobble.” If it does, the rim is out of round or not “true.” If the wobble is noticeable, see your dealer for inspection.

Front Wheel Removal

RIGHT FRONT

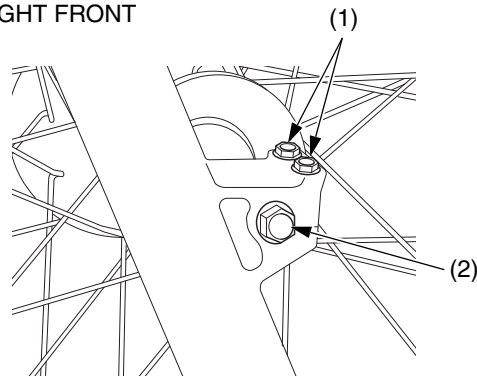

- (1) axle pinch bolts
- (2) front axle shaft

Removal

1. Raise the front wheel off the ground by placing a maintenance stand or support block under the engine. Secure the rear of the motorcycle with tie-down straps.
2. Loosen the axle pinch bolts (1).
3. Unscrew and remove the front axle shaft (2). Remove the wheel and side collars.

Avoid depressing the brake lever when the wheel is off the motorcycle. This will force the caliper pistons out of the cylinders. The result will be loss of brake fluid. If this occurs, the brake system will require service. See your dealer for this service.

Avoid getting grease, oil, or dirt on the disc or pad surfaces. Any contamination can cause poor brake performance or rapid pad wear after reassembly.

Wheels

Installation

1. Installation is the reverse order of removal.
Install the side collars into the wheel in their original locations. Carefully fit the brake disc between the pads to avoid scratching them.
2. Insert the front axle shaft from the right side, through the axle holder, wheel hub and left fork leg.
3. Tighten the front axle shaft to the specified torque:
44 lbf·ft (59 N·m, 6.0 kgf·m)
4. Tighten the axle pinch bolts until lightly seated.
5. Operate the front brake and pump the fork several times.
6. Tighten the axle pinch bolts to the specified torque.
16 lbf·ft (22 N·m, 2.2 kgf·m)
7. After installing the wheel, apply the brake several times and then check if the wheel rotates freely. Recheck the wheel if the brake drags or if the wheel does not rotate freely. Check front brake adjustment (page 82).

If a torque wrench was not used to install the wheel, see your dealer as soon as possible to verify proper assembly. Improper assembly may lead to loss of braking capacity.

Rear Wheel Removal

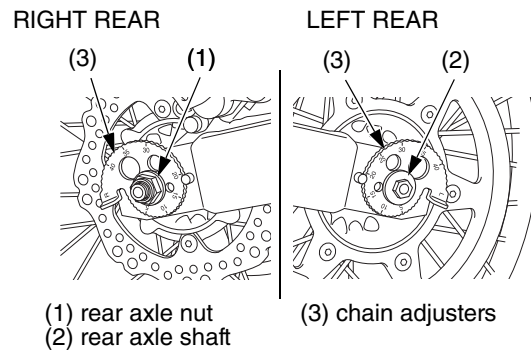

Removal

1. Raise the rear wheel off the ground by placing a maintenance stand or support block under the engine. Secure the front of the motorcycle with tie-down straps.

2. Loosen the rear axle nut (1) while holding the rear axle shaft (2).
3. Turn both chain adjusters (3) so the rear wheel can be moved all the way forward for maximum drive chain slack.
4. Remove the rear axle nut. Push the wheel forward and derail the drive chain from the driven sprocket.
5. Remove the rear axle, chain adjusters, rear wheel and side collars.
Avoid depressing the brake pedal when the wheel is off the motorcycle. This will force the caliper piston out of the cylinder. The result will be a loss of brake fluid. If this occurs, the brake system will require service. See your dealer for this service.
Avoid getting grease, oil, or dirt on the disc or pad surfaces. Any contamination can cause poor brake performance or pad wear after reassembly.

Wheels

RIGHT REAR

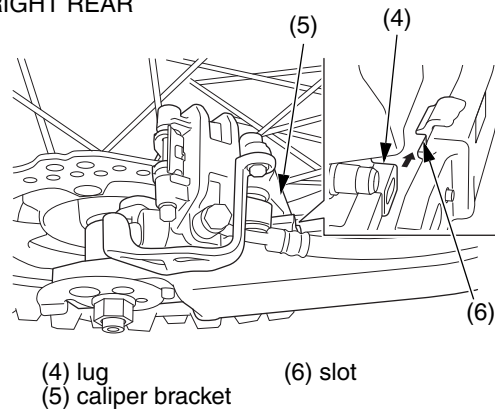

Installation

1. Installation is the reverse order of removal.
Install the side collars into the wheel in their original locations. Carefully fit the brake disc between the pads to avoid scratching them. Make sure the lug (4) on the caliper bracket (5) is located in the slot (6) in the swingarm. Check that the chain adjusters are installed properly.
2. Adjust the drive chain (page 102).
3. Tighten the rear axle nut to the specified torque:
80 lbf·ft (108 N·m, 11.0 kgf·m)
4. After installing the wheel, apply the brake pedal several times, then check if the wheel rotates freely. Recheck the wheel if the brake drags or if the wheel does not rotate freely.

If a torque wrench was not used to install the wheel, see your dealer as soon as possible to verify proper assembly. Improper assembly may lead to loss of braking capacity.

Tires & Tubes

Refer to *Safety Precautions* on page 39.

To safely operate your motorcycle, the tires must be the proper type (off-road) and size, in good condition with adequate tread, and correctly inflated.

⚠ WARNING

Using tires that are excessively worn or improperly inflated can cause a crash in which you can be seriously hurt or killed.

Follow all instructions in this owner's manual regarding tire inflation and maintenance.

The following pages give detailed information on how and when to check your air pressure, how to inspect your tires for wear and damage,

and our recommendations on tire repair and replacement.

Air Pressure

Properly inflated tires provide the best combination of handling, tread life, and riding comfort. Generally, underinflated tires wear unevenly, adversely affect handling, and are more likely to fail from being overheated. Underinflated tires can also cause wheel damage in rocky terrain. Overinflated tires make your motorcycle ride harshly, are more prone to damage from surface hazards, and wear unevenly.

Make sure the valve stem caps are secure. If necessary, install new caps.

Tires & Tubes

Always check air pressure when your tires are “cold.” If you check air pressure when your tires are “warm” – even if your motorcycle has only been ridden for a few miles – the readings will be higher. If you let air out of warm tires to match the recommended cold pressures, the tires will be underinflated.

The correct “cold” tire pressures are:

Front	15 psi (100 kPa, 1.0 kgf/cm ²)
Rear	15 psi (100 kPa, 1.0 kgf/cm ²)

If you decide to adjust tire pressures for a particular riding condition, make changes a little at a time.

Inspection

A flat tire or blowout is inconvenient and may even cause a crash. Take time to inspect your tires and wheels before you ride. For more information about handling flat tires, see page 131.

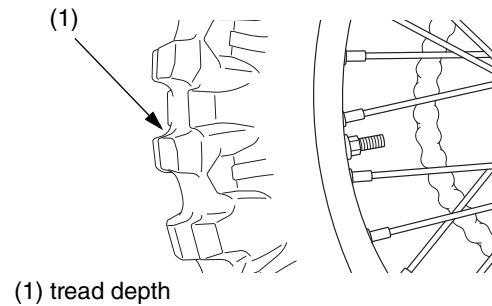

Tires & Tubes

- Inspect carefully for bumps or bulges in the side of the tire or the tread. Replace any tire that has a bump or bulge.
- Look closely for cuts, slits, or cracks in the tires. Replace a tire if you can see fabric or cord.
- Check for rocks or other objects embedded in the tire or tread. Remove any objects.
- Measure tread depth (1). Replace the tire before depth at the center reaches 0.12 in (3 mm), or any time you notice a reduction in traction.
- Check the position of both valve stems. A tilted valve stem indicates the tube is slipping inside the tire or the tire is slipping on the rim. See your dealer.

Tube Replacement

If a tube is punctured or damaged, you should replace it as soon as possible. A repaired tube may not have the same reliability as a new one, and it may fail while you are riding. For information on making a temporary repair, see page 131.

Use a replacement tube equivalent to the original.

We recommend that tubes be replaced by your dealer. Replacing a tube requires removing and reinstalling the wheel. Any time a tube is replaced, carefully inspect the tire as described on page 94.

Tires & Tubes

Tire Replacement

The tires that came on your motorcycle were designed to provide a good combination of handling, braking, durability, and comfort across a broad range of riding conditions.

⚠ WARNING

Installing improper tires on your motorcycle can affect handling and stability. This can cause a crash in which you can be seriously hurt or killed.

Always use the size and type of tires recommended in this owner's manual.

Front	80/100-21 51R NHS
Rear	100/100-18 59R NHS
Type	bias-ply, tube

- Use a replacement tire equivalent to the original.
- Replace the tube any time you replace a tire. The old tube will probably be stretched and, if installed in a new tire, could fail.
- Have the wheel balanced after a new tire is installed.
- We recommend that tires be replaced by your dealer.

Side Stand

Refer to *Safety Precautions* on page 39.

LEFT SIDE

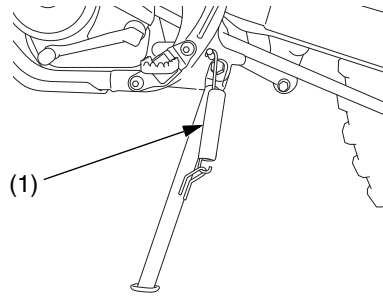

(1) side stand spring

1. Check the side stand spring (1) for damage and loss of tension.
2. Check the side stand assembly for freedom of movement.

If the side stand is stiff or squeaky, clean the pivot area and lubricate the pivot bolt with clean engine oil.

Drive Chain

Refer to *Safety Precautions* on page 39.

The service life of the chain depends on proper lubrication and adjustment. Poor maintenance can cause premature wear or damage to the drive chain or sprockets.

Under severe usage, or when the motorcycle is ridden in unusually dusty or muddy areas, more frequent maintenance will be necessary.

Before servicing your drive chain, turn the engine OFF, lower the side stand, and check that your transmission is in neutral.

It is not necessary to remove or replace the drive chain to perform the recommended service in the Maintenance Schedule.

Inspection

LEFT SIDE

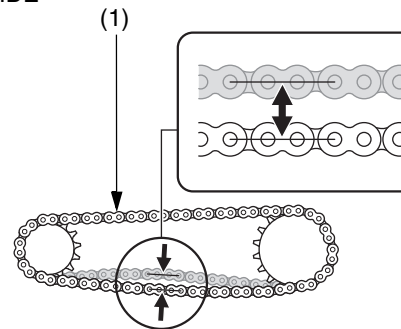

(1) drive chain

1. Move the lower part of the drive chain up and down to check chain slack, midway between the sprockets.
1 3/16 – 1 9/16 in (30 – 40 mm)

Drive Chain

2. Check drive chain slack at several points along the chain. The slack should remain constant. If it isn't, some links may be kinked and binding. Lubricating the chain will often eliminate binding and kinking.

NOTICE

Excessive chain slack may allow the drive chain to damage the engine cases.

3. Inspect the drive chain for:

- damaged rollers
- loose pins
- dry or rusted links
- kinked or binding links
- excessive wear
- damaged or missing O-rings

Replace the drive chain (page 104) if it has damaged rollers, loose pins, or kinks that cannot be freed. Lubricate the drive chain (page 103) if it appears dry or shows signs of rust. Lubricate any kinked or binding links and work them free. Adjust chain slack if needed.

(cont'd)

Drive Chain

4. Check the chain slider (2), chain guide slider (3) and chain roller (4) for wear. If the chain slider is worn to the bottom of the cutout (5), have your dealer replace the slider.

Replace the chain guide slider if the chain is visible through the wear inspection window (6). New chain guide slider should be installed by sliding from the front of the vehicle.

Replace the chain roller if it is smaller than 0.7 in (18 mm).

LEFT SIDE

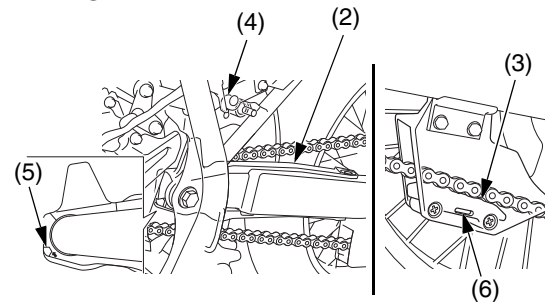

- (2) chain slider (5) cutout
(3) chain guide slider (6) wear inspection window
(4) chain roller

5. Replace the drive chain if chain slack is excessive when the rear axle is moved to the farthest limit of adjustment. Excessive slack indicates the chain is worn beyond its service limit.

Drive Chain

To check the chain's service limit, measure the distance between a span of 41 pins, from pin center to pin center. If the distance exceeds the service limit, the drive chain is worn out and should be replaced.

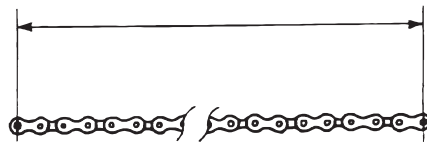

Measure a span of 41 pins

New Chain: 25.0 in (635 mm)

Service Limit: 25.1 in (638 mm)

This motorcycle has a staked master link drive chain which requires a special tool for cutting and staking. Do not use an ordinary master link with this chain.

6. Inspect the front and rear sprocket teeth for excessive wear or damage. If necessary, have your dealer replace a worn sprocket.

Damaged Sprocket
Teeth

Worn Sprocket
Teeth

REPLACE

REPLACE

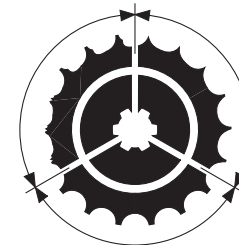

Normal Sprocket Teeth
GOOD

NOTICE

Use of a new chain with worn sprockets will cause rapid chain wear.

Drive Chain

Adjustment

LEFT REAR

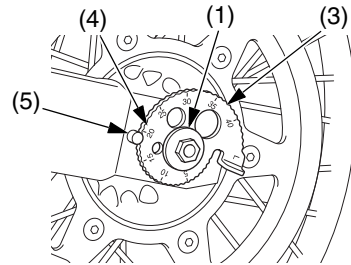

RIGHT REAR

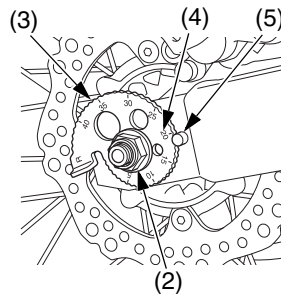

- (1) rear axle shaft
- (2) rear axle nut
- (3) chain adjusters
- (4) index marks
- (5) stopper pins

1. Hold the rear axle shaft (1) and loosen the rear axle nut (2).
2. Turn both the right and left chain adjusters (3) equally to increase or decrease chain slack.
3. After adjusting, be sure the same adjuster index marks (4) align with the stopper pins (5) on both sides of the swingarm.
4. Tighten the rear axle nut to the specified torque:
80 lbf·ft (108 N·m, 11.0 kgf·m)
5. Recheck drive chain slack.

If a torque wrench is not used for this installation, see your dealer as soon as possible to verify proper assembly.

Drive Chain

Lubrication

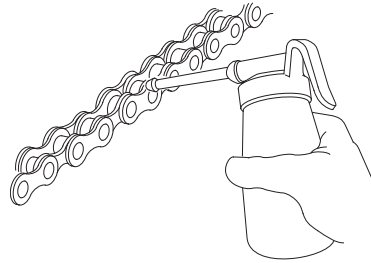

Lubricate every 300 miles (500 km) or sooner if chain appears dry.
The O-rings in this chain can be damaged by steam cleaning, high pressure washers, and certain solvents.

Recommended lubricant: Pro Honda HP Chain Lube or equivalent.

Commercial chain lubricants not designed for motorcycle drive chains may contain solvents which could damage the O-rings.

Drive Chain

Removal, Cleaning & Replacement

Your motorcycle has an endless (riveted master link) type chain. It should only be removed or replaced by your dealer.

When the drive chain becomes extremely dirty, it should be cleaned prior to lubrication.

1. Clean the side surfaces of the chain with a dry cloth.
Do not brush the rubber O-rings. Brushing will damage them. Use of a solvent may also damage the O-rings.
2. Inspect the drive chain for possible wear or damage. Replace the drive chain if it has damaged rollers, loose fitting links, or otherwise appears unserviceable.

Replacement chain:
DID 520VD2

3. Inspect the sprocket teeth for wear or damage. We recommend replacing the sprocket whenever a new chain is installed.
4. Lubricate the drive chain.

Battery

Your motorcycle has a maintenance-free type battery. You do not have to check the battery electrolyte level or add distilled water as you would with a conventional-type battery.

NOTICE

Your battery is a maintenance-free type and can be permanently damaged if the cap strip is removed.

Electrical accessories use current from the battery, even when the ignition is OFF. Limited operation also allows the battery to discharge. If you have electrical accessories on your motorcycle or do not ride frequently, we recommend that you charge the battery frequently (see *Battery Charging*, page 109).

If you do not expect to ride your motorcycle for at least two weeks, we recommend you remove the battery, or at least disconnect the battery cables (negative cable first).

If you plan to store your motorcycle, see *Battery Storage*, page 106.

If your battery seems weak and/or is leaking electrolyte (causing slow starting or other electrical problems), see your dealer.

WARNING: Battery posts, terminals and related accessories contain lead and lead compounds. **Wash hands after handling.**

Battery

Battery Storage

Refer to *Safety Precautions* on page 39.

If you plan to store your motorcycle, we recommend you remove the battery and store it where it can be charged at least every 30 days to maintain its service life.

If you do not remove the battery, we recommend disconnecting the battery cables (negative cable first).

You will get the best storage results from removing the battery and slow charging it every 30 days (see *Battery Charging*, page 109).

Before you remove the battery, be sure to read all the information that follows, as well as the information on the battery label.

⚠ WARNING

The battery gives off explosive hydrogen gas during normal operation.

A spark or flame can cause the battery to explode with enough force to kill or seriously hurt you.

Wear protective clothing and a face shield, or have a skilled mechanic do the battery maintenance.

Battery

The battery is located in the battery compartment behind the left side cover.

Removal

1. Make sure the ignition switch is OFF.
2. Remove the left side cover (page 53).

LEFT SIDE

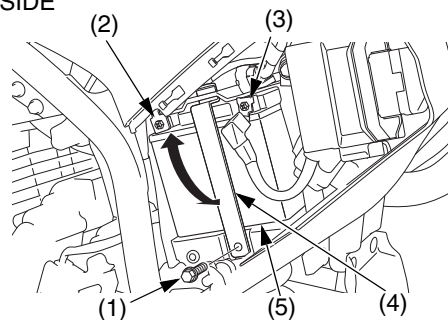

- (1) battery holder bolt
- (2) negative (-) terminal
- (3) positive (+) terminal
- (4) battery holder
- (5) battery

3. Remove the battery holder bolt (1).
4. Disconnect the negative (-) terminal (2) from the battery.
5. Disconnect the positive (+) terminal (3) from the battery.
6. Raise the battery holder (4), then remove the battery (5) taking care not to drop the terminal nuts.

(cont'd)

Battery

7. Charge the battery (see following section), unless you have been riding regularly.
8. Store your battery in an easy-to-reach location off the floor, in an area protected from freezing temperatures and direct sunlight.
9. Clean the battery box after removing the battery for storage.
10. Slow charge the battery (see following section) once every 30 days.

Installation

1. Reinstall in the reverse order of removal. Be sure to connect the positive (+) terminal first, then the negative (-) terminal.
2. Check all bolts and other fasteners are secure.

Battery

Battery Charging

Refer to *Safety Precautions* on page 39.

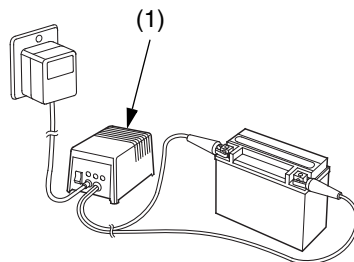

(1) charger

Be sure to read the information that came with your battery charger and follow the instructions on the battery. Improper charging may damage the battery.

We recommend using a charger (1) designed specifically for your Honda, which can be purchased from your dealer. These units can be left connected for long periods without risking damage to the battery. However, do not intentionally leave the charger connected longer than the time period recommended in the charger's instructions.

Avoid using an automotive-type battery charger. An automotive charger can overheat a motorcycle battery and cause permanent damage.

Appearance Care

Refer to *Safety Precautions* on page 39.

Frequent cleaning and polishing will keep your Honda looking newer longer. Frequent cleaning also identifies you as an owner who values your motorcycle. A clean motorcycle is also easier to inspect and service.

While you're cleaning, be sure to look for damage, wear, and gasoline or oil leaks.

General Recommendations

- To clean your motorcycle, you may use:
 - water
 - a mild, neutral detergent and water
 - a mild spray and wipe cleaner/polisher
 - a mild spray and rinse cleaner/degreaser and water
- Avoid products that contain harsh detergents or chemical solvents that could damage the metal, paint, and plastic on your motorcycle.
- If your motorcycle is still warm from recent operation, give the engine and exhaust system time to cool off.

Appearance Care

- We recommend the use of a low pressure garden hose to wash your motorcycle. High pressure washers (like those at coin-operated car washes) can damage certain parts of your motorcycle. If you use a high pressure washer, avoid spraying the following areas:

- wheel hubs
- muffler outlet
- area under seat
- engine stop button
- brake master cylinder
- under fuel tank
- drive chain
- throttle body

NOTICE

High pressure water (or air) can damage certain parts of your motorcycle.

Washing Your Motorcycle with a Mild Detergent

1. Rinse your motorcycle thoroughly with cool water to remove loose dirt.
2. Fill a bucket with cool water. Mix in a mild, neutral detergent, such as dish washing liquid or a product made especially for washing motorcycles or automobiles.
3. Wash your motorcycle with a sponge or a soft towel. As you wash, check for heavy grime. If necessary, use a mild cleaner/degreaser to remove the grime.
4. After washing, rinse your motorcycle thoroughly with plenty of clean water to remove any residue. Detergent residue can corrode alloy parts.

(cont'd)

Appearance Care

5. Dry your motorcycle with a chamois or a soft towel. Leaving water on the surface to air dry can cause dulling and water spots. As you dry, inspect for chips and scratches.
6. Lubricate the drive chain to prevent rusting.
7. Start the engine and let it idle for several minutes. The engine heat will help dry moist areas.
8. As a precaution, ride at a slow speed and apply the brakes several times. This will help dry the brakes and restore normal braking performance.

Exhaust Pipe and Muffler Maintenance

When the exhaust pipe and muffler are painted, do not use a commercially available abrasive kitchen cleaning compound. Use a neutral detergent to clean the painted surface on the exhaust pipe and muffler. If you are not sure if your exhaust pipe and muffler are painted, contact your dealer.

Appearance Care

Clean the Matte Painted Surface

Refer to *Safety Precautions* on page 39.

Use a soft cloth or sponge, plenty of water, and a mild detergent to clean the matte paint. Dry with a soft, clean cloth.

Do not use polishing compounds or wax containing polishing compounds. These can damage or discolor the paint.

To keep your Honda looking new, clean and polish it frequently.

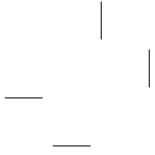

This page intentionally left blank.

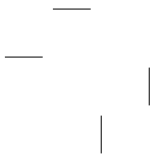

Tips

Here's helpful advice on how to prepare for an off-road adventure, how to transport and store your Honda, and how to be an environmentally responsible motorcycle owner.

Preparing for a Ride	116
Transporting Your Honda	118
Storing Your Honda	120
You & the Environment.....	123

Preparing for a Ride

A safe and enjoyable ride begins with good planning and preparation. Always ride with at least one other person in case you have trouble, and let someone know where you're going and when you expect to return.

Before riding in an unfamiliar area, find out in advance if you need special permits, get maps so you can study the terrain, and talk to other riders who know the area. The Forest Service and the Bureau of Land Management (USA only), the Ministry of Natural Resources (Canada only), riding clubs, and off-road magazines are good sources of information.

What to Take to the Riding Area

Along with your motorcycle and riding gear, you should take along some tools and supplies in case you have a problem. For some of the difficulties you might encounter, see *Taking Care of the Unexpected*, which begins on page 125.

We recommend that you always take water, food, a first aid kit, and your owner's manual. Other items you should consider loading on your truck or trailer include:

- a tool kit
- tire repair supplies and tools, tubes, and tires
- extra parts, such as a drive chain, control levers, cables, and spark plugs
- wire, duct tape, and rope
- extra gasoline

Preparing for a Ride

For safety, all refueling should be done at a gas station on the way to the riding area or at your base camp.

What to Take on the Trail

What you take with you during a ride depends on the kind of terrain, how long you expect to ride, how far you might go from your base camp or help, and how experienced you or your companions are in making repairs.

If you decide to take some tools, spare parts, or other supplies on the trail, be sure you can carry them safely and know how to use them. Also, be sure to follow the loading guidelines and weight limit (page 6).

Transporting Your Honda

If you use a truck or motorcycle trailer to transport your Honda, we recommend that you follow these guidelines:

- Use a loading ramp.
- Secure the motorcycle in an upright position, using motorcycle tie-down straps. Avoid using rope, which can loosen and allow the motorcycle to fall over.

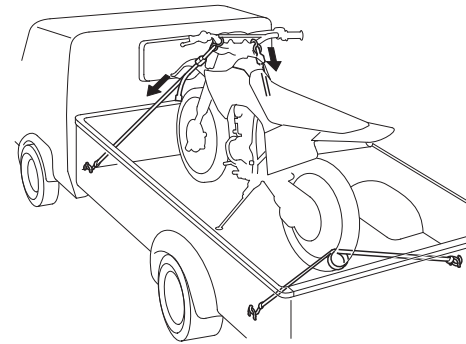

To secure your motorcycle, brace the front wheel against the front of the truck bed or trailer rail. Attach the lower ends of two straps to the tie-down hooks on your vehicle. Attach the upper ends of the straps to the handlebar (one on the right side, the other on the left), close to the fork.

Transporting Your Honda

Check that the tie-down straps do not contact any control cables or electrical wiring.

Tighten both straps until the front suspension is compressed about half-way. Too much pressure is unnecessary and could damage the fork seals.

Use another tie-down strap to keep the rear of the motorcycle from moving.

We recommend that you do not transport your motorcycle on its side. This can damage the motorcycle, and leaking gasoline could be a hazard.

Storing Your Honda

If you won't be riding for an extended period, such as during the winter, thoroughly inspect your motorcycle and correct any problem before storing it. That way, needed repairs won't be forgotten and it will be easier to get your motorcycle running again.

USA: For more information about storage, refer to the *Honda Winter Storage Guide*, available from your dealer.

Canada: For more information about storage, visit our website at www.honda.ca and look up "Storage Tips" under the "Honda Warranty" in the Warranty tab for your model.

We suggest you perform the following procedures to keep your motorcycle in top condition. These storage procedures will reduce the deterioration that can occur during storage.

Storing Your Honda

Preparation for Storage

1. Change the engine oil (page 61).
2. Fill the fuel tank. Make sure the fuel fill cap is properly installed.

(cont'd)

Tips 121

Storing Your Honda

3. Remove the battery and charge it fully. Store it in an area protected from freezing temperatures and direct sunlight. Slow charge the battery (page 109) once a month.
4. Wash and dry your motorcycle.
5. Lubricate the drive chain (page 103).
6. Inflate the tires to their recommended pressures (page 93).
7. Store your motorcycle in an unheated area, free of dampness, away from sunlight, with a minimum of daily temperature variation.
8. Cover your motorcycle with a porous material. Avoid using plastic or similar non-breathing, coated materials that restrict air flow and allow heat and moisture to accumulate.

Removal from Storage

1. Uncover and clean your motorcycle.
2. If your motorcycle has been stored for more than four months – change the engine oil (page 61).
3. If your motorcycle has been stored for more than two months – drain and replace the fuel.
4. Charge the battery (page 109) as required. Install the battery.
5. Lubricate the drive chain (page 103).
6. Perform a pre-ride inspection (page 22), then test-ride your motorcycle at low speeds.

You & the Environment

Owning and riding a motorcycle can be enjoyable, but you must do your part to protect nature. When you show respect for the land, wildlife, and other people, you also help preserve the sport of off-road riding.

Following are tips on how you can be an environmentally responsible motorcycle owner.

- **Tread Lightly.** Stay on existing roads and trails, avoid surfaces that are easily damaged, and ride only in areas approved for off-road vehicles.
- **Keep the Noise Down.** Loud motorcycles can be offensive. Ride as quietly as possible, don't remove your spark arrester, and don't modify the muffler or any other part of your air intake and exhaust systems. Such modifications not only increase noise, they also reduce engine performance and may be illegal.

- **Choose Sensible Cleaners.** Use a biodegradable detergent when you wash your motorcycle. Avoid aerosol spray cleaners that contain chlorofluorocarbons (CFCs) which damage the atmosphere's protective ozone layer. Don't throw cleaning solvents away; see the following guidelines for proper disposal.

(cont'd)

You & the Environment

- **Recycle Wastes.** It's illegal and thoughtless to put used engine oil in the trash, down a drain, or on the ground. Used oil, gasoline, and cleaning solvents contain poisons that can hurt refuse workers and contaminate our drinking water, lakes, rivers, and oceans. Before changing your oil, make sure you have the proper containers. Put oil and other toxic wastes in separate sealed containers and take them to a recycling center. Call your local or state office of public works or environmental services to find a recycling center in your area and get instructions on how to dispose of non-recyclable wastes.

Taking Care of the Unexpected

With all the challenges you can encounter off-road, there's a chance that sometime something may go wrong. This section gives practical advice to help you deal with a wide range of problems. Take time to read this section before you ride. Also review the tips in *Preparing for a Ride* (page 116).

General Guidelines.....	126
If Your Engine Quits or Won't Start.....	127
If You Have a Flat Tire	131
If a Fuse Blows	132
If You Crash.....	135
If You Lose Your Key.....	136
If a Component Fails.....	137
If Your Battery Is Low (or Dead)	138

Taking Care of the Unexpected

General Guidelines

If something goes wrong during a ride, the first thing to do is stop as soon as you safely can. Do not continue riding if you have a flat tire, or you hear an unusual noise, or your motorcycle just doesn't feel right. If you continue riding, you could cause more damage and endanger your own safety.

After a stop, take time to assess the situation. Carefully inspect your motorcycle to identify the problem, then consider your options before you decide what to do.

If a problem is relatively minor and you have the tools, supplies, and skills to make a permanent repair, you may be able to fix it on the trail and continue riding. Or, you may be able to make a temporary repair that allows you to slowly ride back to your base where you can make a permanent repair or get help.

When a problem is more serious – or you don't have the tools, supplies, experience, or time to deal with it – you need to choose the safest way to get yourself and your motorcycle back to base. For example, if you are close enough, you (or you and another person) might be able to push it back.

Whatever the problem, the most important rules are:

- Always put personal safety first.

Taking Care of the Unexpected

- If the problem is relatively minor and you have the tools, supplies, and skills to make a temporary repair, be sure to have permanent repairs made as soon as possible.
- Do not continue riding if you are hurt or your motorcycle is not in safe riding condition.

Additional recommendations for specific problems follow.

If Your Engine Quits or Won't Start

Proper operation and maintenance can prevent starting and engine performance problems. In many cases, the cause of the problem may be a simple operational oversight.

If you have a problem starting the engine – or experience poor engine performance – the following information may help you. If you can't correct the problem, see your dealer.

If your motorcycle won't start, listen as you press the start button. If you don't hear the starter motor turning, refer to the *Starter motor doesn't operate* symptom. If you can hear the starter motor working normally, refer to the *Starter motor works, but the engine won't start* symptom.

Taking Care of the Unexpected

SYMPTOM: Starter motor doesn't operate.	
POSSIBLE CAUSE	WHAT TO DO
ignition switch OFF	Turn the ignition switch ON.
transmission not in neutral	Shift into neutral.
blown fuse	Replace with a new fuse of the same rating (page 132).
battery lead loose	Tighten the battery lead.
low (or dead) battery	Charge the battery (page 109). If charging doesn't help, see your dealer.
faulty starter motor	If all possible causes are negative, the starter motor may be faulty. See your dealer.

Taking Care of the Unexpected

SYMPTOM: Starter motor works, but the engine won't start.	
POSSIBLE CAUSE	WHAT TO DO
out of fuel	Fill the fuel tank.
flooded engine	See <i>Flooded Engine</i> (page 28).
loose or unconnected spark plug cap	Install the spark plug cap securely. If the engine still won't start, see your dealer.
loose battery cables	Tighten the battery terminal bolts.
weak battery	Charge the battery (page 109). If charging doesn't help, see your dealer.

SYMPTOM: Engine starts, but runs poorly.	
POSSIBLE CAUSE	WHAT TO DO
idles roughly, too fast, stalls	See your dealer.
runs erratically, misfires	See your dealer.
blubbers (rich fuel mixture)	See your dealer.

Taking Care of the Unexpected

SYMPTOM: Engine starts, but runs poorly. (cont'd)	
POSSIBLE CAUSE	WHAT TO DO
sooty exhaust (rich fuel mixture)	See your dealer.
detonates or pings under load	If applicable, switch to the recommended octane gasoline (page 54) or change your brand of gasoline. If the problem persists, see your dealer.
afterfires (backfires)	See your dealer.
pre-ignition (runs on after ignition switched OFF)	See your dealer.

Taking Care of the Unexpected

If You Have a Flat Tire

How you handle a flat tire on the trail depends on how serious the tube or tire damage is, and what tools and supplies you have with you.

If you have a slow leak or a minor puncture, there are two ways to try making a temporary repair:

- Use an aerosol tire sealer to seal the puncture and inflate the tube. (This can be done without removing the tire or wheel.)
- Use a tube patch kit to repair the puncture. (This requires removing the tire.)

If the leak is more serious, or a temporary repair doesn't hold, the tube must be replaced. The tire will also need to be replaced if it is damaged (page 96). Replacing a tube or tire involves removing and re-installing the wheel (pages 89, 91).

If you are unable to repair a flat tire on the trail, you will need to push the motorcycle back to your base or send for help. We strongly recommend that you do not try to ride with a flat tire. The motorcycle will be hard to handle, and if the tire comes off the rim, it may lock up the wheel and cause you to crash.

Taking Care of the Unexpected

⚠ WARNING

Riding your motorcycle with a temporary tire repair can be risky.

If the temporary repair fails, you can crash and be seriously injured or killed. If you must ride with a temporary tire repair, ride slowly and carefully until the tire is permanently repaired or replaced.

If a Fuse Blows

All of the electrical circuits on your motorcycle have fuses to protect them from damage caused by excess current flow (short circuit or overload).

If something electrical on your motorcycle stops working, the first thing you should check for is a blown fuse.

Check the fuses before looking elsewhere for another possible cause of the problem. Replace any blown fuse and check component operation.

The main fuse and sub fuse are located behind the left side cover.

Recommended Fuses

main fuse	10 A
sub fuse	5 A

Taking Care of the Unexpected

1. To prevent an accidental short circuit, turn the ignition switch OFF before checking or replacing the fuse.
2. For access the main fuse (1) and sub fuse (2), remove the left side cover (page 53).

Main Fuse Access:

3. Remove the starter magnetic switch (3) from the ribs (4) of the battery box.
4. Disconnect the wire connector (5) of the starter magnetic switch.
5. Pull the fuse out. If the main fuse is blown (6), install the spare main fuse (7).
6. Reconnect the wire connector.
7. Install the starter magnetic switch.

LEFT SIDE

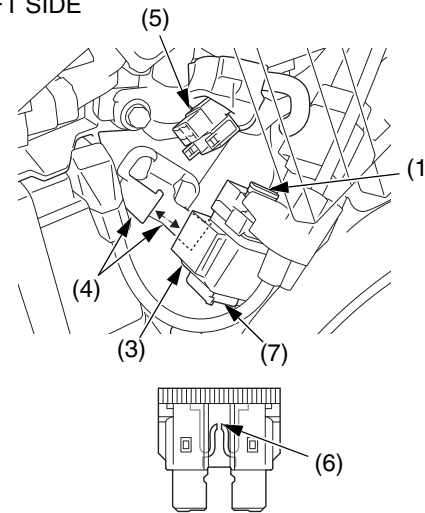

- | | |
|-----------------------------|---------------------|
| (1) main fuse | (5) wire connector |
| (3) starter magnetic switch | (6) blown fuse |
| (4) ribs | (7) spare main fuse |

Taking Care of the Unexpected

Sub Fuse Access:

8. Remove the fuse case (8) from the rib (9) of the battery box.
9. Open the fuse case cover and pull the sub fuse out. If the fuse is blown (10), replace it with a spare fuse (11).
10. Install the left side cover.

If you do not have a replacement fuse with the proper rating for the circuit, install one with a lower rating.

NOTICE

Replacing a fuse with one that has a higher rating greatly increases the chance of damage to the electrical system.

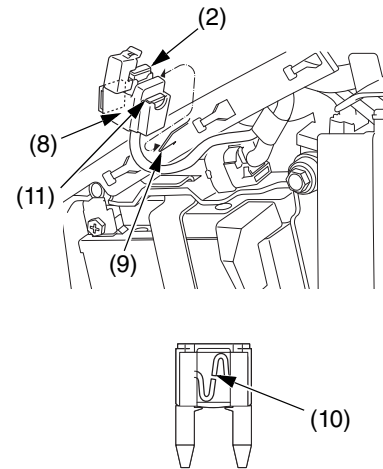

(2) sub fuse
(8) fuse case
(9) rib

(10) blown fuse
(11) spare fuse

Taking Care of the Unexpected

If You Crash

Personal safety is your first priority after a crash. If you or anyone else has been injured, take time to assess the severity of the injuries and whether it is safe to continue riding. If you cannot ride safely, send someone for help. Do not ride if you will risk further injury.

If you decide that you are capable of riding safely, first evaluate the condition of your motorcycle. If the engine is still running, turn it off and look it over carefully; inspect it for fluid leaks, check the tightness of critical nuts and bolts, and secure such parts as the handlebar, control levers, brakes, and wheels.

If there is minor damage, or you are unsure about possible damage but decide to try riding the motorcycle back to your base, ride slowly and cautiously.

Sometimes, crash damage is hidden or not immediately apparent. When you get home, thoroughly check your motorcycle and correct any problems you find. Also, be sure to have your dealer check the frame and suspension after any serious crash.

Taking Care of the Unexpected

If You Lose Your Key

Be sure to record the key number provided with the original keys. Store the spare key and recorded key number in a safe location. You'll need this number to have a duplicate key made.

If you lose your key and aren't carrying a duplicate, either get your spare or have one made. If you don't know your key number, call the dealer where you purchased your Honda. They may have it listed in their records. If they don't, transport your motorcycle to them or the nearest dealer. The dealer will probably have to remove the ignition switch assembly to find the key number so they can make a key for you.

Taking Care of the Unexpected

If a Component Fails

The drive chain, brake lever or pedal, control cables, and other components can be damaged as you ride in dense brush or over rocky terrain. Making a trailside repair depends on how serious the damage is and what tools and supplies you have with you.

- If the chain breaks or does other damage when it comes off, you may not be able to make a trailside repair.

- If any component of the front brake system is damaged, you may be able to ride carefully back to your base using the rear brake for slowing or stopping.
- If the clutch lever breaks, you may be able to temporarily switch the front brake lever to the clutch side, then ride carefully back to base using the rear brake for slowing or stopping.
- If you damage a throttle cable or other critical component, your motorcycle may be unsafe to ride. Carefully assess the damage and make any repairs that you can. But if there is any doubt, it's best to be conservative and safe.

Taking Care of the Unexpected

If Your Battery Is Low (or Dead)

Jump starting is not recommended, especially if you use an automobile battery. The greater amperage of an automobile battery when the car engine is running can damage your motorcycle's electrical system.

Bump starting is also not recommended.

If you can't charge the battery or it appears unable to hold a charge, contact your dealer.

Taking Care of the Unexpected

If Unstable Engine Operation Occurs Intermittently

If the fuel pump filter is clogged, unstable engine operation will occur intermittently while riding.

Even if this symptom occurs, you can continue to ride your motorcycle.

If unstable engine operation occurs even if sufficient fuel is available, have your motorcycle inspected by your dealer as soon as possible.

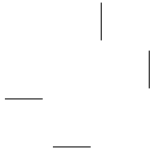

This page intentionally left blank.

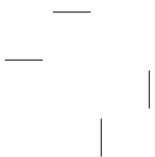

Technical Information

This section contains dimensions, capacities, and other technical data, plus information on government requirements and how to break-in your motorcycle.

Vehicle Identification.....	142
Specifications	144
Break-in Guidelines	149
Emission Control Systems	150
Oxygenated Fuels.....	155

Vehicle Identification

Serial Numbers

The VIN and engine serial number are required when you register your motorcycle. They may also be required when ordering replacement parts. You may record these numbers in the *Quick Reference* section at the rear of the manual.

The VIN (1) is stamped on the right side of the steering head.

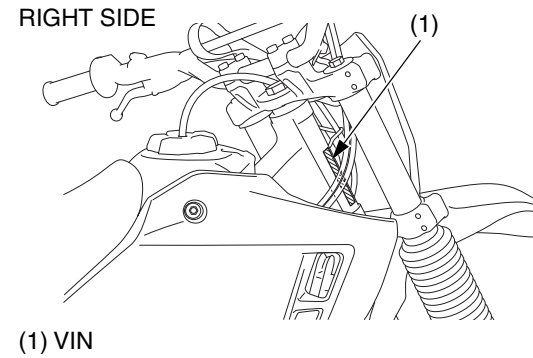

Vehicle Identification

The engine number (2) is stamped on the left side of the engine.

LEFT SIDE

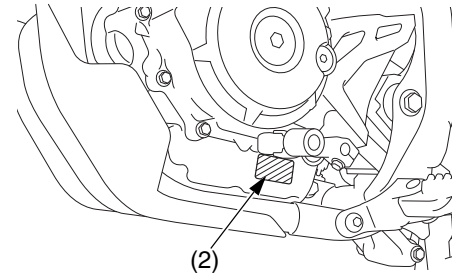

(2) engine number

Specifications

Dimensions	
Overall length	82.9 in (2,105 mm)
Overall width	31.5 in (800 mm)
Overall height	46.9 in (1,190 mm)
Wheelbase	55.9 in (1,420 mm)

Fuel & Lubricants	
Fuel tank capacity	1.6 US gal (6 ℓ) including reserve
Fuel tank reserve	0.34 US gal (1.3 ℓ)
Fuel recommendation	unleaded gasoline, pump octane number of 86 or higher
Engine oil capacity	after draining: 1.6 US qt (1.5 ℓ) after draining and oil filter change: 1.7 US qt (1.6 ℓ) after disassembly: 2.1 US qt (2.0 ℓ)

Specifications

Fuel & Lubricants	
Engine oil recommendation	API Service Classification SJ or higher except oils labeled as energy conserving or resource conserving on the circular API service label, SAE 10W-30, JASOT 903 standard MA, Pro Honda GN4 4-stroke oil (USA & Canada), or Honda 4-stroke oil, or an equivalent motorcycle oil
Drive chain lubricant	Pro Honda HP Chain Lube or equivalent

Fuel & Lubricants	
Air cleaner oil	Pro Honda (USA only) or Honda Foam Filter Oil or an equivalent

Capacities	
Passenger capacity	operator only; no passenger
Maximum weight capacity	220 lb (100 kg)
Cargo capacity	none

Engine Specifications	
Displacement	17.9 cu-in (293 cm ³)
Bore & stroke	3.0 × 2.5 in (77.0 × 63.0 mm)
Compression ratio	9.3 : 1

Specifications

Engine Specifications	
Valve clearance (cold)	Intake: 0.005 ± 0.001 in (0.12 ± 0.03mm) Exhaust: 0.008 ± 0.001 in (0.20 ± 0.03 mm)
Spark plug (standard)	SILMAR7D9DS (NGK)
Spark plug gap	0.03–0.04 in (0.8–0.9 mm)
Idle speed (non-adjustable)	1,500 ±100 rpm

Power Transmission	
Primary reduction	2.652
Gear ratio, 1st	3.272
2nd	2.058
3rd	1.500
4th	1.260
5th	1.080
6th	0.962
Final reduction	3.571
Final drive	chain

Specifications

Power Transmission	
Drive chain freeplay	1 3/16 – 1 9/16 in (30 – 40 mm)
New chain length	25.0 in (635 mm) distance between a span of 41 pins
Used chain service limit length	25.1 in (638 mm) distance between a span of 41 pins

Chassis & Suspension	
Caster	25° 48'
Trail	3.9 in (100 mm)
Tire size, front	80/100-21 51R NHS
Tire size, rear	100/100-18 59R NHS
Tire type	bias-ply, tube
Tire pressure, front (cold)	15 psi (100 kPa, 1.0 kgf/cm ²)
Tire pressure, rear (cold)	15 psi (100 kPa, 1.0 kgf/cm ²)
Suspension, front	8.5 in (216 mm) axle travel
Suspension, rear	9.1 in (230 mm) axle travel

Specifications

Electrical	
Battery	YTZ7S 12 V – 6 Ah (10 HR)
Generator	0.14 kW/5,000 rpm

Fuse	
Main	10 A
Sub	5 A

Torque Specifications	
Oil drain bolt	18 lbf·ft (24 N·m, 2.4 kgf·m)
Front wheel axle	44 lbf·ft (59 N·m, 6.0 kgf·m)
Axle holder nuts	16 lbf·ft (22 N·m, 2.2 kgf·m)
Rear wheel axle	80 lbf·ft (108 N·m, 11.0 kgf·m)
Oil filter cover bolt	9 lbf·ft (12 N·m, 1.2 kgf·m)
Muffler tail cover bolt	9 lbf·ft (12 N·m, 1.2 kgf·m)

Break-in Guidelines

Help assure your motorcycle's future reliability and performance by paying extra attention to how you ride during the first operating day or 15 miles (25 km). During this period, avoid full-throttle starts and rapid acceleration.

Emission Control Systems

Exhaust Emission Requirements

The U.S. Environmental Protection Agency (EPA), the California Air Resources Board (CARB), and Environment and Climate Change Canada (ECCC) require that your motorcycle comply with applicable exhaust emissions standards during its useful life, when operated and maintained according to the instructions provided.

The Vehicle Emission Control Information Label (1) (2) is attached to the rear fender.

REAR FENDER
(For USA)

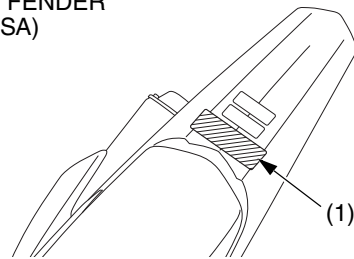

(For Canada)

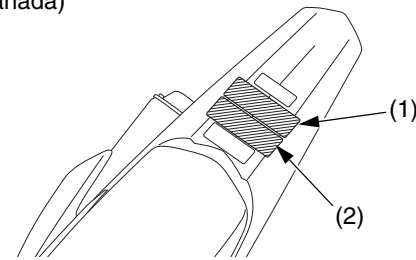

(1) vehicle emission control
information label

(2) vehicle emission control
information label (Canada only)

Noise Emission Requirements

The EPA also requires that motorcycles built after January 1, 1983 comply with applicable noise emission standards for one year or 1,865 miles (3,000 km) after the time of sale to the ultimate purchaser, when operated and maintained according to the instructions provided. (USA only)

Emission Control Systems

Source of Emissions

The combustion process produces carbon monoxide (CO), oxides of nitrogen (NO_x), and hydrocarbons (HC). Control of hydrocarbons and oxides of nitrogen is very important because, under certain conditions, they react to form photochemical smog when subjected to sunlight. Carbon monoxide does not react in the same way, but it is toxic.

Honda Motor Co., Ltd. utilizes various systems to reduce carbon monoxide, oxides of nitrogen and hydrocarbons.

Exhaust Emission Control System

The exhaust emission control system includes a PGM-FI system.

No adjustment to this system should be made although periodic inspection of the components is recommended.

The exhaust emission control system is separate from the crankcase emission control system.

Emission Control Systems

Evaporative Emission Control System (USA - 50 states [meets California])

An evaporative emission control system uses pressure proof fuel tank and fuel fill cap which maintains inside of the fuel tank at a high pressure to keep fuel vapor in itself while the engine is off.

Models sold in and used in California

An add-on or modified part must be compliant with applicable ARB evaporative emission control standards. A violation of this requirement is punishable by civil and/or criminal punishment.

Crankcase Emission Control System

The engine is equipped with a closed crankcase system to prevent discharging crankcase emissions into the atmosphere.

Blow-by gas is returned to the combustion chamber through the air cleaner and the throttle body.

Noise Emission Control System

TAMPERING WITH THE NOISE CONTROL SYSTEM IS PROHIBITED: U. S. federal law prohibits, or Canadian provincial laws may prohibit the following acts or the causing thereof: (1) The removal or rendering inoperative by any person, other than for purposes of maintenance, repair or replacement, of any device or element of design incorporated into any new vehicle for the purpose of noise control prior to its sale or delivery to the ultimate purchaser or while it is in use; or (2) the use of the vehicle after such device or element of design has been removed or rendered inoperative by any person.

Emission Control Systems

AMONG THOSE ACTS PRESUMED TO CONSTITUTE TAMPERING ARE THE ACTS LISTED BELOW:

- Removal of, or puncturing the muffler, baffles, header pipes, or any other component which conducts exhaust gases.
- Removal of, or puncturing of any part of the intake system.
- Lack of proper maintenance.
- Removing or disabling any emissions compliance component, or replacing any compliance component with a non-compliant component.

Problems that May Affect Motorcycle Emissions

If you are aware of any of the following symptoms, have the vehicle inspected and repaired by your Honda Motorcycle Dealer:

1. Hard starting or stalling after starting
2. Rough idle
3. Misfiring or backfiring during acceleration
4. After-burning (backfiring)
5. Poor performance (drivability) and poor fuel economy

Federal regulations prohibit removing or disabling a device or element of design that may affect your engine's emission performance unless your motorcycle will be used exclusively in competition. If you modify your engine for use in sanctioned competition events, you must deface or destroy the emission control information label.

Emission Control Systems

If you loan, sell, or give your competition modified motorcycle to someone else, according to applicable law, you must inform the new owner/operator in writing that the vehicle is to be used for competition only.

Fuel Permeation Emission Control System

This vehicle complies with the Fuel Permeation Emission Control regulations of the U.S. Environmental Protection Agency (EPA), the California Air Resources Board (CARB), and Environment and Climate Change Canada (ECCC).

The fuel tank, fuel hoses, and fuel vapor charge hoses used on this vehicle incorporate fuel permeation control technologies. Tampering with the fuel tank, fuel hoses, or fuel vapor charge hoses to reduce or defeat the effectiveness of the fuel permeation technologies is prohibited by federal regulations.

Oxygenated Fuels

Some conventional gasolines are being blended with alcohol or an ether compound. These gasolines are collectively referred to as oxygenated fuels. To meet clean air standards, some areas of the United States and Canada use oxygenated fuels to help reduce emissions.

If you use an oxygenated fuel, be sure it is unleaded and meets the minimum octane rating requirement.

Before using an oxygenated fuel, try to confirm the fuel's contents. Some states/provinces require this information to be posted on the pump.

The following are percentages of oxygenates:

ETHANOL (ethyl or grain alcohol) up to 10% by volume

You may use gasoline containing up to 10% ethanol by volume. Gasoline containing ethanol may be marketed under the name "Gasohol".

Do not use gasoline containing METHANOL (methyl alcohol).

Oxygenated Fuels

If you notice any undesirable operating symptoms, try another service station or switch to another brand of gasoline.

Fuel system damage or performance problems resulting from the use of an oxygenated fuel containing more than the percentages of oxygenates mentioned above are not covered under warranty.

Oxygenated fuels can damage paint and plastic. Be careful not to spill fuel when filling the fuel tank. Wipe up any spills immediately.

NOTICE

Oxygenated fuels can damage paint and plastic. Damage caused by spilled fuel is not covered under warranty.

Consumer Information

This section contains information on your warranty and how to get an official Honda service manual.

Authorized Manuals	158
Warranty Coverage	159
Warranty Service.....	160
Contacting Honda	161
Your Honda Dealer	162

Authorized Manuals

USA The Service Manual used by your authorized dealer is available from your Honda dealer or Helm, Inc.

Canada See your dealer to order authorized manuals.

Also available, but not necessary to service your model, is the Honda Common Service Manual, which explains basic service information for various systems on Honda motorcycles, scooters, and ATV.

USA The Winter Storage Guide in conjunction with the Owner's Manual and Service Manual can help you prepare your Honda motorcycle, scooter, ATV, and SxS for winter storage.

These Honda manuals are written for the professional technician. However, if you possess the proper tools, observe the safety standards, and are mechanically capable, you should find them easy to use.

Special Honda tools are necessary for some procedures.

USA
Order online: www.helminc.com

Order Toll Free: 1-888-CYCLE93
 (1-888-292-5393)

(NOTE: For Credit Card Orders Only)
 Monday – Friday 8:00 AM – 6:00 PM EST

Description
2026 CRF300F Service Manual
Common Service Manual (61CSM00)
USA Winter Storage Guide (S9507)
2026 CRF300F Owner's Manual

Warranty Coverage

Your new Honda is covered by these warranties:

- Motorcycle Limited Warranty
- Emission Control System Warranty
- Noise Control Warranty (USA only)

There are responsibilities, restrictions, and exclusions which apply to these warranties. Please read the Warranties Booklet given to you by your Honda dealer at the time of purchase. Be sure to keep your Honda owner's card with your Warranties Booklet.

Canada: Please refer to the Warranty Booklet posted on our website at www.honda.ca.

It is important to realize that your warranty for your Honda applies to defects in material or factory workmanship. Your warranty coverage does not apply to normal wear or deterioration associated with using the motorcycle.

Your warranty coverage will not be voided if you choose to perform your own maintenance. However, you should have the proper tools and service information and be mechanically qualified. Failures that occur due directly to improper maintenance or lack of maintenance are not covered.

Almost all of your warranty coverage can be extended through the HondaCare® Protection Plan (USA only). For more information, see your dealer.

Warranty Service

Please remember that recommended maintenance interval servicing is not included in your warranty coverage. Additionally, your warranty does not apply to the normal wear of items (such as brakes, tires, etc.).

If you believe you have a problem with your Honda, call the service department of your dealer. Make an appointment for an inspection and diagnosis. Remember, as the owner of the motorcycle, you will be asked to authorize that inspection. Your dealer will give you the results of the inspection. If the problem is covered under warranty, your dealer will perform the warranty repairs for you.

If you have questions about warranty coverage or the nature of the repair, it is best to talk to the Service Manager of your dealer.

Sometimes, despite the best intentions of all concerned, a misunderstanding may occur. If you aren't satisfied with your dealer's handling of the situation, we suggest you discuss your problem with the appropriate member of the dealership's management team. If the problem has already been reviewed with the Service Manager, Parts Manager, Sales Manager, etc., contact the Owner of the dealership or their designated representative.

Contacting Honda

Your owner's manual was written to cover most of the questions you might ask about your Honda. Any questions not answered in the owner's manual can be answered by your dealer. If they don't have the answer right away, they will get it for you.

If you have a difference of opinion with your dealer, please remember that each dealership is independently owned and operated. That's why it's important to work to resolve any differences at the dealership level.

If you wish to contact Honda directly to comment on your experiences with your Honda or with your dealer, please send your comments using one of the following methods:

USA:

 Post Mail
Powersports Customer Relations
American Honda Motor Co., Inc.
4900 Marconi Drive
Alpharetta, GA 30005-8847

 Phone

Telephone: (866) 784-1870

 Online Customer Service

Website:

<https://power.sports.honda.com/contact-us>

Canada: Honda Canada Inc., Customer Relations Dept, 180 Honda Boulevard, Markham, Ontario L6C 0H9, telephone: (888) 946-6329, facsimile: (877) 939-0909.

E-mail: honda_cr@ch.honda.com

Please include the following information in your letter:

- name, address, and telephone number
- product model, year, and VIN
- date of purchase
- dealer name and address

We will likely ask your dealer to respond, or possibly acknowledge your comments directly.

Your Honda Dealer

Once you purchase your new Honda, get familiar with the organization of your Honda dealer so you can utilize the full range of services available.

The service department is there to perform regular maintenance and unexpected repairs. It has the latest available service information from Honda. The service department will also handle warranty inspections and repairs.

The parts department offers Honda Genuine Parts, Pro Honda products, Honda Accessories (USA only), and Honda accessories and products (Canada only). The same quality that went into your Honda can be found in Honda Genuine replacement parts. You'll also find comparable quality in the accessories and products available from the parts department.

The sales department offers the HondaCare[®] Protection Plan to extend almost all of your warranty coverage (USA only).

Your dealer can inform you about competition and other riding events in your area. You'll also find that your dealer is a source of information (USA only) about safety training available in your local area.

We're sure you'll be as pleased with the service your Honda dealer continues to provide after the sale as you are with the quality and dependability of your Honda.

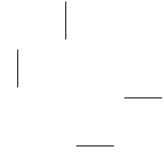
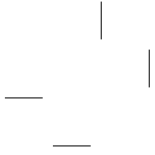

This page intentionally left blank.

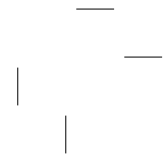
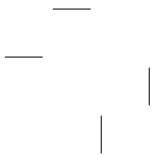

Index

A

accessories	7
air cleaner	64
air pressure, tires	93
altering your motorcycle	8
arrester, spark	77
authorized manuals	158

B

bank angle sensor ignition cut-off system	28
battery	105
brakes,	
fluid level	83
lever, front	16
lever, front adjustment	82
pad wear	85
pedal, rear	17
braking	31

break-in guidelines	149
button,	
engine stop	16
start	16

C

capacity, fuel	55
cleaner, air	64
cleaning, appearance care	110
clutch system,	
adjustment	72
lever	17
competition inspection	46

Index

consumer information 157
controls, operating 11
cover removal, side 53
crankcase breather 68
customer service 161

D

drive chain 98

E

education, rider 3, 162
emission control systems 150
emission requirements 150
engine number 143
engine,
 flooded 28
 pinging 54

starting 27
stop button 16
stopping 28
won't start 127
environment, protecting 123

F

filter, air 64
flat tire 131
flooded engine, starting 28
fork 79
front brake,
 lever 16
 lever freeplay 82
front suspension 79
front wheel removal 89

Index

fuel,
oxygenated 155
recommendation 54
reserve indicator 18
tank capacity 55
fuse 132

G

gap, spark plug 75
gasohol 155
gasoline 54
gears, shifting 29

H

Honda service manual 158
Honda, contacting 161

I

ignition switch 15
inspection,
competition 46
post-ride 34
pre-ride 22

K

key, lost 136

L

lever,
clutch 17
front brake 16
shift 17

Index

limit, weight 6
loading 5

M

maintenance,
 component locations 49
 record 45
 safety 39
 schedule 41
manual, service 158
modifications 8

O

oil, engine 57
operating controls 11
operation component locations 12
oxygenated fuels 155

P

parking 33
pedal, rear brake 17
pgm-fi malfunction indicator lamp (MIL) ... 18
pinging, engine 54
plug, spark 75
post-ride inspection 34
pre-ride inspection 22

Index

R

rear wheel removal	91
reserve capacity, fuel tank	55
rider training	3, 162
riding,	
basic operation	25
before	19
clothing	20
precautions	26
safety	2
rim lock	88

S

schedule, maintenance	41
service,	
customer	161
manuals	158
warranty	160

shifting gears	29
side cover, removal	53
side stand	17, 97
spark arrester	77
spark knock	54
spark plug	75
specifications	144
stand, side	17, 97
start button	16
starting, engine	27
stop button, engine	16
stopping engine	28
storage	120
suspension,	
front	79
rear	80

Index

T

throttle,	
freeplay	69
operation	16
tires,	
air pressure	93
flat	131
replacing	96
tools	52
towing	30
training, rider	3, 162
transporting	118
troubleshooting, starting	127

V

vehicle identification no. (VIN)	142
--	-----

W

warranty,	
coverage	159
extended	159
service	160
washing your motorcycle	111
weight limit	6
wheels	87

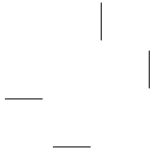

170 Memo

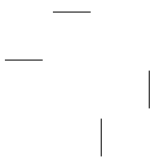

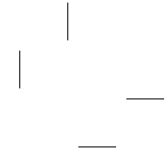
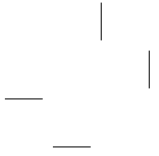

Memo 171

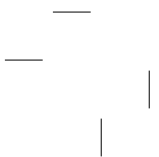

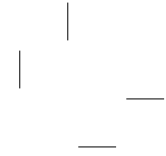
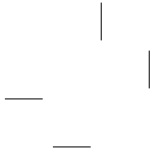

172 Memo

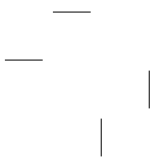

Quick Reference

The following is a brief, but important collection of information you need to know about your Honda. You'll also find space to record important notes.

How To Avoid Costly Repairs

Your Honda engine can be the most expensive component to repair. Proper maintenance, especially the use of the recommended fluids and filters, prevents premature wear and damage.

Frequent causes of costly engine repairs are:

- Engine oil -- insufficient quantity, improper oil.
- Air cleaner -- dirty, cleaned but not oiled, leaking because of improper installation (poor seal).

Frequent causes of costly chassis repair are:

- Chain -- A loosely adjusted chain or a chain stretched because of lack of lubrication may come off and damage an engine case or wheel hub.
- Spokes -- Loose spoke may break and damage the wheel hub or rim.

Record important information on the following page:

Quick Reference

Quick Reference

Record important information here:

VIN	
Engine No.	
Owner's:	
Name	
Address	
City/State	
Phone	
Dealer's:	
Name	
Address	
City/State	
Phone	
Service Mgr.	

Quick Reference



Quick Reference

Initial Maintenance	about 100 miles (150 km) or 1 month.
Regular Maintenance	about every 600 miles (1,000 km) or 6 months.
Pre-ride Inspection	Check the following items each time before you ride (page 22): tires, spokes & rims, leaks, engine oil, fuel, drive chain, cables, nuts & bolts, spark plug & cap, throttle, brakes, and clutch lever.
Fuel/Capacity	unleaded gasoline, pump octane number of 86 or higher tank: 1.6 US gal (6 ℓ) reserve: 0.34 US gal (1.3 ℓ)
Engine Oil/Capacity	API Service Classification SJ or higher except oils labeled as energy conserving or resource conserving on the circular API service label, SAE 10W-30, JASO T 903 standard MA, Pro Honda GN4 4-stroke oil (USA & Canada), or Honda 4-stroke oil, or an equivalent motorcycle oil after draining: 1.6 US qt (1.5 ℓ) after draining and oil filter change: 1.7 US qt (1.6 ℓ)
Maximum Weight Capacity	220 lb (100 kg) rider only (no passenger or cargo) and any accessories
Tires	Front: 80/100-21 51R NHS Rear: 100/100-18 59R NHS Type: bias-ply, tube
Tire Pressure (cold)	Front: 15 psi (100 kPa, 1.0 kgf/cm ²) Rear: 15 psi (100 kPa, 1.0 kgf/cm ²)
Spark Plug	SILMAR7D9DS (NGK)
Fuse	main: 10 A sub: 5 A

Quick Reference

Quick Reference

These symbols are used in Operating Controls section:

SYMBOL	COMPONENT	SEE PAGE
●	ON – ignition switch	15
OFF	OFF – ignition switch	15
	START button	16
	fuel reserve indicator	18

Quick Reference

California Proposition 65 Warning

⚠ WARNING: Operating, servicing and maintaining a passenger vehicle or off-highway motor vehicle can expose you to chemicals including engine exhaust, carbon monoxide, phthalates, and lead, which are known to the State of California to cause cancer and birth defects or other reproductive harm. To minimize exposure, avoid breathing exhaust, do not idle the engine except as necessary, service your vehicle in a well-ventilated area and wear gloves or wash your hands frequently when servicing your vehicle. For more information go to www.P65Warnings.ca.gov/passenger-vehicle.

Quebec Regulatory Notice

Availability of spare parts, repair service and information for maintenance or repair:

Pursuant to applicable Quebec regulation, Honda does not guarantee the availability of replacement parts, repair services, or information required for the maintenance or repair of this product or its components.

For more information visit: www.honda.ca/en/quebecregulatorynotice