

250 DUKE

ITEM NO.: 3240320EN



Congratulations on your decision to purchase a KTM motorcycle. You are now the owner of a state-of-the-art sports vehicle which, with proper care, will bring you pleasure for a long time to come.

We hope you enjoy your bike and have a safe journey at all times!

You can enter the serial numbers of your vehicle below to find the serial numbers more quickly if required:

<u>Vehicle identification number</u>	Stamp of the contractual partner
<u>Engine number</u>	

The owner's manual contained the latest information for this model series at the time of publication. However, minor differences due to further developments in design cannot be ruled out completely.

All specifications are non-binding. KTM Sportmotorcycle GmbH specifically reserves the right to modify or delete technical specifications, prices, colors, forms, materials, services, designs, equipment, etc., without prior notice and without specifying reasons, to adapt these to local conditions, as well as to stop production of a particular model without prior notice. KTM accepts no liability for delivery options, differences from illustrations and descriptions, misprints, and other errors. The models portrayed partly contain special equipment that does not belong to the regular scope of supply.

© 2026 KTM Sportmotorcycle GmbH, Mattighofen Austria

All rights reserved. Figures: Mitterbauer / Visus Studios / KISKA / KTM

Written permission from the copyright owner is required before any duplication or reproduction.

ISO 9001

KTM applies quality assurance processes that lead to the highest possible product quality as defined in the ISO 9001 international quality management standard.



12 100 6061

Issuing institution:

TÜV SÜD Management Service GmbH

KTM Sportmotorcycle GmbH
Stallhofnerstraße 3
5230 Mattighofen, Austria

This document is valid for:

- 250 DUKE B.D. RW (F4202Z1, F4202Z2)
- 250 DUKE B.D. RW (F4202Z1L, F4202Z2L)
- 250 DUKE JP (F4286Z1, F4286Z2)
- 250 DUKE CO (F4241Z1, F4241Z2)
- 250 DUKE AR (F4242Z1, F4242Z2)



Table of contents

1	Means of representation	7	6.12	Ignition and steering lock	19
1.1	Conventions.....	7	6.13	USB socket	19
1.1.1	Icons	7	6.14	Locking the steering	20
1.1.2	Formatting	7	6.15	Unlocking the steering	20
1.1.3	Abbreviations	7	6.16	Opening the fuel tank cap	20
2	Safety	8	6.17	Closing the fuel tank cap	21
2.1	Safety instructions	8	6.18	Seat lock	22
2.2	Ban on tampering	8	6.19	On-board tool kit	22
2.3	Safe use	9	6.20	Passenger strap	22
2.4	Protective clothing	9	6.21	Passenger footpegs	22
2.5	Work rules	9	6.22	Gear shift lever	23
2.6	Environment	10	6.23	Brake pedal	23
2.7	Owner's manual	10	6.24	Side stand	24
2.8	Defined use	10	7	Combination instrument	25
2.9	Improper use	10	7.1	Combination instrument	25
3	Important notes	11	7.2	activation and testing	25
3.1	Manufacturer's warranty, implied warranty	11	7.2.1	Activation	25
3.2	Auxiliary material, operating material	11	7.2.2	Test.....	26
3.3	Spare parts, accessories	11	7.3	warnings	26
3.4	Service	11	7.4	indicator lamps	26
3.5	Figures	11	7.5	Display	28
3.6	Customer service	11	7.6	speed	28
3.7	Roadside Assistance	12	7.7	shift light	29
4	View of the vehicle	13	7.8	speed display	29
4.1	View of vehicle, front left (example)	13	7.9	time	29
4.2	View of vehicle, rear right (example)	14	7.10	ABS display	30
5	Serial number	15	7.11	coolant temperature indicator	30
5.1	Vehicle identification number	15	7.12	fuel level display	31
5.2	Type approval label	15	7.13	Favorites display	31
5.3	Engine number	15	7.14	Quick Selector 1 display	31
5.4	Key number	15	7.15	Quick Selector 2 display	31
6	Controls	16	7.16	Navigation display (optional)	32
6.1	Clutch lever	16	7.17	Call display	32
6.2	Handbrake lever	16	7.18	Remote Control Mode (optional)	32
6.3	Throttle grip	16	7.19	Menu	33
6.4	Combination switch	16	7.19.1	ABS	33
6.5	Hazard warning flasher switch	17	7.19.2	Bike info	34
6.5.1	Hazard warning flasher switch.....	17	7.19.3	Bike info	34
6.6	Menu buttons	17	7.19.4	Warning	34
6.7	Horn button	17	7.19.5	Trip info	34
6.8	Light switch	18	7.19.6	Trip 1	35
6.9	Turn signal switch	18	7.19.7	Trip 2	35
6.10	Kill switch	18	7.19.8	Navigation (optional)	35
6.11	Electric starter	19	7.19.9	Volume (optional)	36
			7.19.10	start/stop navigation (optional)	36
			7.19.11	Audio	37
			7.19.12	Lap timer	37
			7.19.13	Delete All Rounds	38
			7.19.14	Settings	38
			7.19.15	favorites	38
			7.19.16	Quick selector 1	38

























7.19.17	Quick selector 2	39	12.4	Taking the motorcycle off the front lifting gear	63
7.19.18	connectivity	39	12.5	Cleaning the dust boots of the fork legs	64
7.19.19	Bluetooth	39	12.6	Removing the passenger seat	64
7.19.20	pairing a phone	40	12.7	Mounting the passenger seat	65
7.19.21	headset pairing	41	12.8	Remove the front rider's seat	65
7.19.22	Type of audio device	42	12.9	Mounting the front rider's seat	65
7.19.23	QUICKSHIFTER+ (optional)	42	12.10	Checking the chain for dirt	66
7.19.24	Shift Light	42	12.11	Cleaning the chain	66
7.19.25	Shift light state	43	12.12	Checking the chain tension	67
7.19.26	RPM1	43	12.13	Adjusting the chain tension	67
7.19.27	RPM2	43	12.14	Checking the chain, rear sprocket, and engine sprocket	68
7.19.28	Setting the time and date	44	13	Brake system	70
7.19.29	Date format	44	13.1	Anti-lock braking system	70
7.19.30	Units	44	13.2	Checking the brake discs	71
7.19.31	Distance	45	13.3	Checking the brake fluid level for the front brake	72
7.19.32	Temperature	45	13.4	Adding brake fluid for the front brake 	72
7.19.33	Consumption	45	13.5	Checking that the brake pads of the front brake are secured	73
7.19.34	Extra Functions	46	13.6	Checking the brake fluid level for the rear brake	74
8	Preparing for use	47	13.7	Adding brake fluid for the rear brake 	74
8.1	Notes on preparing for first use	47	13.8	Checking that the brake pads of the rear brake are secured	76
8.2	Running in the engine	48	14	Wheels, tires	77
8.3	Loading the vehicle	48	14.1	Removing the front wheel 	77
9	Riding instructions	50	14.2	Installing the front wheel 	77
9.1	checks and maintenance measures when preparing for use	50	14.3	Removing the rear wheel 	78
9.2	Starting	50	14.4	Installing the rear wheel 	79
9.3	Starting off	51	14.5	Checking the rear hub damping rubber pieces 	80
9.4	Quickshifter+ (optional)	52	14.6	Checking the tire condition	81
9.5	Shifting, riding.	52	14.7	Checking the tire pressure	82
9.6	Braking.	55	15	Electrics	83
9.7	Stop, park	56	15.1	Removing the 12 V battery 	83
9.8	Transport	57	15.2	Installing the 12 V battery 	84
9.9	Towing in the event of a breakdown	57	15.3	Charging the 12 V battery 	84
9.10	Refueling	58	15.4	Changing the main fuse	86
10	Service schedule	59	15.5	Changing the ABS fuses	88
10.1	Service work	59	15.6	Changing the fuses of individual electrical power consumers	89
11	Tuning the chassis	61	15.7	Checking the headlight setting	91
11.1	Adjusting the spring preload of the shock absorber 	61	15.8	Adjusting the headlight range	91
11.2	Adjusting the shift lever	61			
12	Service work on the chassis	62			
12.1	Raising the motorcycle with rear lifting gear	62			
12.2	Removing the rear of the motorcycle from the lifting gear	62			
12.3	Lifting the motorcycle with the front lifting gear	62			

Table of contents

15.9	Diagnostic connector	92	22.4	Fork	115
15.10	Front ACC1 and ACC2	92	22.4.1	Technical data - fork	115
15.11	Rear ACC1 and ACC2	92	22.4.2	Fork oil capacity	116
16	Cooling system	93	22.5	Shock absorber	116
16.1	Cooling system	93	22.5.1	Technical data - shock absorber	116
16.2	Checking the frost protection and coolant level	93	22.6	Tightening torque	116
16.3	Checking the coolant level	95	22.6.1	Engine tightening torques	116
16.4	Draining the coolant 	96	22.6.2	Chassis tightening torques	119
16.5	Filling/bleeding the cooling system 	96	23	Declarations of conformity	124
16.6	Changing the coolant 	98	23.1	Declarations of conformity	124
17	Tuning the engine	101	23.2	Country-specific declarations of conformity	124
17.1	Checking the play in the clutch lever	101	24	Recycling	125
17.2	Adjusting play in the clutch lever 	101	24.1	Recycling	125
18	Service work on the engine	102	Notes	127	
18.1	Checking the engine oil level	102	A	Technical terms	127
18.2	Changing the engine oil and oil filter, cleaning the oil screens 	102	B	Fuels.....	128
18.3	Adding engine oil	104	C	Operating supplies.....	129
19	Cleaning, care	105	D	Electrics.....	131
19.1	Cleaning the motorcycle	105	E	Cleaning agents.....	134
19.2	Checks and maintenance steps for winter operation	106	F	Icons.....	135
20	Storage	108	F.1	Symbol colors	135
20.1	Storage	108	F.1.1	Red symbols.....	135
20.2	Preparing for use after storage	109	F.1.2	Yellow and orange symbols	135
21	Troubleshooting	110	F.1.3	Green and blue symbols	135
21.1	Troubleshooting	110	Index	136	
22	Technical specifications	112			
22.1	Engine	112			
22.1.1	Technical data - engine	112			
22.1.2	Capacities - engine	113			
22.2	Chassis	113			
22.2.1	Technical data - chassis	113			
22.2.2	Technical data - tires	114			
22.2.3	fuel	114			
22.2.4	Capacities - vehicle	115			
22.3	Electrics	115			
22.3.1	Battery	115			
22.3.2	Fuses	115			
22.3.3	Lamps	115			

1.1 Conventions

1.1.1 Icons

-  Indicates a desired result (e.g. of a work step or a function).
-  Indicates an undesired result (e.g. of a work step or a function).
-  All work marked with this symbol requires specialist knowledge and technical understanding. Ensure that this work is carried out or supervised by trained personnel from an authorized contractual partner, and that any special tools required are used.
-  Indicates a page reference.
-  Indicates information with more details.
-  Indicates a tip, e.g. to simplify work.
-  Indicates the result from a test step.
-  Indicates the end of an activity, including any rework.

1.1.2 Formatting

Proprietary name	Indicates a proprietary name.
Name[®]	Indicates a protected name.
Brand[™]	Indicates a brand available on the open market.
<u>Underlined terms</u>	Refer to technical details of the vehicle or indicate technical terms that are explained in the glossary.

1.1.3 Abbreviations

2-pc.	two-part
Part no.	Part number
or	respectively
approx.	circa
etc.	et cetera
poss.	possibly/possible
if necessary	if necessary
cmpl.	complete
min.	at least
no.	number
no fig.	no figure
s.	see
among others	among others/not limited to
and the like	and the like
etc.	et cetera
cf.	compare
e.g.	for example

2.1 Safety instructions

Function of the safety instruction

Safety instruction brings attention to dangers when handling the product. Hazards are classified, named, described, and supplemented with information on how to avoid them.

- If there is a safety instruction before a list of instructions, the danger exists throughout the entire activity.
- If there is a safety instruction immediately before an instruction, the next step presents a danger.

Safety instruction layout

All safety instructions are identified by a signal word and a warning symbol. The combination of signal word and warning symbol determines the degree of danger.



DANGER

Indicates an imminent danger that leads to serious injury or death.



WARNING

Indicates a potentially imminent danger that could lead to serious injury or death.



CAUTION

Indicates a potentially imminent danger that can lead to minor or slight injuries.



NOTE

Indicates a situation that can lead to damage to the product or the product environment.



NOTE

Indicates a situation that can lead to environmental damage.

2.2 Ban on tampering

No changes may be made to the noise control equipment and components.

Tampering that is prohibited

- Removing or disabling any devices or components used for noise control before the new vehicle is sold or delivered to the end customer.
- Removing or disabling any device or component used for noise control for purposes other than service, repair, or replacement during the service life of the vehicle.
- Use of the vehicle after a device or component used for noise control has been removed, disabled, or inadequately maintained.

Examples of prohibited tampering

- Removing or drilling through rear mufflers, baffle plates, manifolds, or other components that conduct exhaust gases.
- Removing or puncturing parts of the intake system.
- Replacing moving parts of the vehicle, or parts of the exhaust system or intake system, with parts other than those specified by the manufacturer.

2.3 Safe use



DANGER

Danger of accidents A rider who is not fit to ride poses a danger to themselves and to others.

- Do not operate the vehicle if you are not fit to ride due to alcohol, drugs, or medication.
- Do not operate the vehicle if you are physically or mentally incapable of doing so.



DANGER

Danger of poisoning Exhaust gases are toxic and inhaling them may result in unconsciousness and death.

- Always ensure that there is sufficient ventilation when running the engine.
- Use suitable exhaust extraction when starting or running the engine in an enclosed space.



WARNING

Danger of burns Some vehicle components become hot when the vehicle is operated.

- Do not touch any parts such as the exhaust system, radiator, engine, damper, or brake system before the vehicle parts have cooled down.
- Allow the vehicle parts to cool down before performing any work on the vehicle.

The vehicle should only be used when it is in perfect technical condition, for its intended purpose, and in a safe and environmentally-friendly manner.

An appropriate driver's license is needed to drive the vehicle on public roads.

Have any faults that impair safety immediately remedied by an authorized contractual partner.

Adhere to the information and warning labels on the vehicle.

2.4 Protective clothing



WARNING

Risk of injury Missing or inadequate protective clothing increases the risk of injury.

- Wear appropriate protective clothing such as helmet, boots, gloves as well as pants and a jacket with protectors on all rides.
- Always wear protective clothing that is in good condition and meets the legal regulations.

2.5 Work rules

Unless specified otherwise, the ignition must be switched off during all work (models with ignition lock, models with transponder key) or the engine must be at a standstill (models without ignition lock or transponder key).

Special tools are required for some work. The tools are not part of the vehicle, but can be ordered using the number in parentheses. Example: bearing puller (15112017000)

Unless otherwise noted, normal conditions apply to all tasks and descriptions.

Ambient temperature	20 °C (68.0 °F)
Ambient air pressure	1,013 mbar (14.69 psi)
Relative air humidity	60 ±5 %

During assembly, use new parts to replace parts which cannot be reused (e.g. self-locking screws and nuts, expansion screws, seals, sealing rings, O-rings, pins, and lock washers).

A thread lock (e.g. **Loctite**®) is required for some screw connections. Observe the manufacturer's specific instructions for use.

If thread lock (e.g. **Precote**®) has already been applied to a new part, do not apply any additional thread lock.

After disassembly, clean the parts that are to be reused and check them for damage and wear. Replace damaged or worn parts.

After completing a repair or service, check the operating safety of the vehicle.

2.6 Environment

Handling the vehicle responsibly reduces the risk of conflict with other road users and the surrounding area. The future of motorcycling also depends on using motorcycles legally, being environmentally conscious and respecting the rights of others.

When disposing of used oil, other operating and auxiliary fluids, and used components, the laws and regulations of the respective country must be observed.

As motorcycles are not subject to the EU regulations governing the disposal of end-of-life vehicles, there are no legal regulations that pertain to the disposal of an end-of-life motorcycle. More information is available from the authorized contractual partner.

2.7 Owner's manual

Read this owner's manual carefully and in full before riding off for the first time. The owner's manual contains information and tips on how to operate, handle, and service your vehicle, as well as advice on optimum tuning and how to avoid injuries.



Tip

Save this owner's manual on your smartphone, for example, so that you can access it at any time.

An authorized contractual partner will be happy to assist you if you are unsure.

The owner's manual is an important component of the vehicle. If the vehicle is sold, the owner's manual must be downloaded again by the new owner.

The owner's manual can be downloaded multiple times using the QR code or the link on the delivery certificate.

The owner's manual is also available for download from your authorized contractual partner and on the KTM website.

International KTM Website: <https://www.ktm.com>

A printed copy can be ordered from the following address.

Website for printed copy: <https://print.ktm.com>

2.8 Defined use

KTM sport motorcycles are designed and constructed to meet the normal demands of regular road operation but not for use on race courses or offroad.



Note

The motorcycle is only authorized for operation on public highways in the homologated version.

2.9 Improper use

The vehicle may only be used as intended.

Improper use can result in danger to people, property and the environment.

Any use of the vehicle beyond the intended and defined use constitutes misuse.

Improper use includes the use of operating and auxiliary materials that do not meet the required specifications for the respective use.

3.1 Manufacturer's warranty, implied warranty

The work prescribed in the service schedule must only be carried out in an authorized contractual partner and confirmed in the **KTM Dealer.net**, as otherwise all warranty claims will be void. Damage or secondary damage caused by tampering with and/or conversions on the vehicle are not covered by the manufacturer's warranty.

3.2 Auxiliary material, operating material

Use operating materials and auxiliary materials in accordance with the operating instructions and specifications.

3.3 Spare parts, accessories

For safety reasons, only spare parts and accessories approved by KTM may be used. They may only be installed by an authorized contractual partner. KTM accepts no liability for other products and any resulting damage or loss. Certain spare parts and accessory products are specified in parentheses in the descriptions. Authorized contractual partners will be happy to help.

The current **KTM PowerParts** are listed for each vehicle on the KTM website.

International KTM Website: <https://www.ktm.com>

3.4 Service

A prerequisite for perfect operation and prevention of premature wear is that the service, care, and tuning work is properly carried out as described in the owner's manual. An incorrect suspension setting can lead to damage and breakage of chassis components.

Use of the vehicle under difficult conditions, such as dusty environments, heavy rain, high heat or with a heavy load, can lead to increased wear of components such as the air filter, powertrain, brake systems, or suspension components. For this reason, it may be necessary to inspect or replace components before the next scheduled service interval.

The prescribed running-in times and service intervals must be observed, otherwise the long-term durability of the vehicle will be severely impaired.

The relevant mileage or time interval is whichever occurs first.

A list of services that have already been carried out on the vehicle can be found in the Service area on the international KTM website:

International KTM Website: <https://www.ktm.com>

Authorized contractual partners will be happy to answer any questions regarding the services performed.

A list of authorized contractual partners can be found on the KTM website.

3.5 Figures

Some of the figures in this document contain optional extras.

For clarity, some components may be shown disassembled or may not be shown at all. Disassembly is not always absolutely necessary in order to carry out the activities described. The textual information takes precedence.

3.6 Customer service

Authorized contractual partners will be happy to answer questions about the vehicle and KTM.

A list of authorized contractual partners can be found on the KTM website.

International KTM Website: <https://www.ktm.com>

3.7 Roadside Assistance

For peace of mind when traveling with your vehicle in Europe, we offer Roadside Assistance free of charge in selected countries (handled in cooperation with a contracting partner).

Each service at your authorized contractual partner extends your free Roadside Assistance until the next service or for a maximum of 12 months.

In the event of a breakdown, call the KTM Assistance Center hotline or contact them directly via the KTMconnect app.

The applicable conditions and benefits can be found on the KTM website:

International KTM Website: <https://www.ktm.com>

4.1 View of vehicle, front left (example)



L05314-10

- | | | | |
|---|--|---|---|
| ① | Combination instrument | ⑥ | Passenger strap  (p. 22) |
| ② | Clutch lever  (p. 16) | ⑦ | Side stand  (p. 24) |
| ③ | Front rider's seat | ⑧ | Gear shift lever  (p. 23) |
| ④ | Seat lock  (p. 22) | ⑨ | Engine number  (p. 15) |
| ⑤ | Passenger seat | | |

4 View of the vehicle

4.2 View of vehicle, rear right (example)

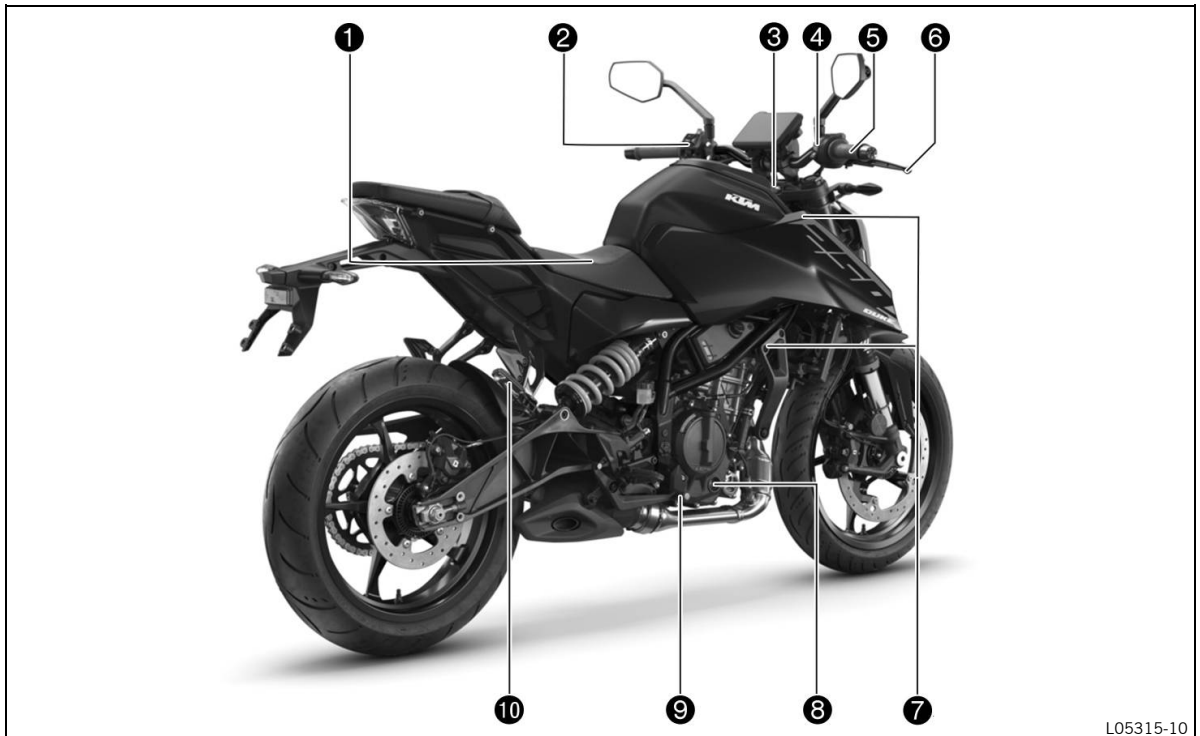

L05315-10

- | | | | |
|---|--------------------------------------|---|---|
| ① | On-board tool kit 📖 (p. 22) | ⑤ | Throttle grip 📖 (p. 16) |
| ② | Light switch 📖 (p. 18) | ⑥ | Handbrake lever 📖 (p. 16) |
| ② | Turn signal switch 📖 (p. 18) | ⑦ | Vehicle identification number 📖 (p. 15) |
| ② | Horn button 📖 (p. 17) | ⑦ | Type approval label 📖 (p. 15) |
| ③ | Ignition and steering lock 📖 (p. 19) | ⑧ | Engine oil level viewer |
| ④ | Kill switch 📖 (p. 18) | ⑨ | Brake pedal 📖 (p. 23) |
| ④ | Electric starter 📖 (p. 19) | ⑩ | Passenger footpegs 📖 (p. 22) |

5.1 Vehicle identification number

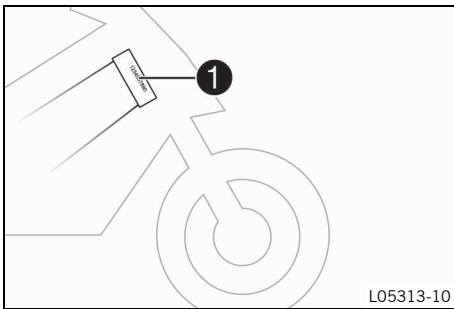

The vehicle identification number ❶ is stamped on the right side of the steering head.

5.2 Type approval label

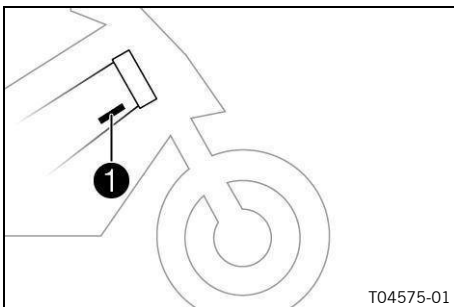

The type label ❶ is on the right of the frame behind the steering head.

5.3 Engine number

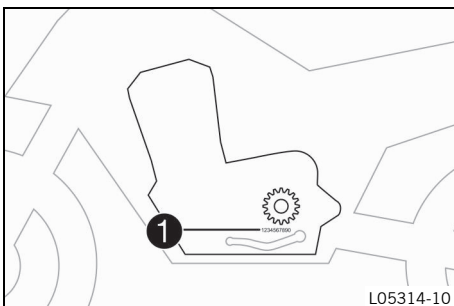

The engine number ❶ is located on the left side of the engine under the engine sprocket.

5.4 Key number

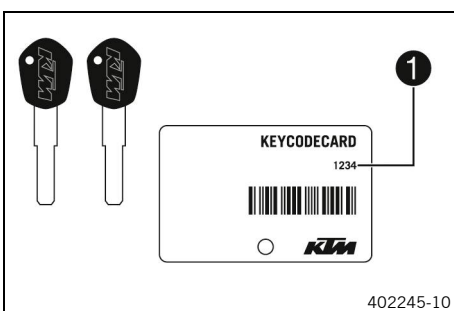

The key number ❶ for the steering lock is stamped onto the key connector.

i Note

The key number is needed to order a spare key. Keep **KEYCODECARD** in a safe place.

If at least one ignition key is still available, a spare key can be produced. If an ignition key is no longer present, the entire lock system must be replaced.

6.1 Clutch lever

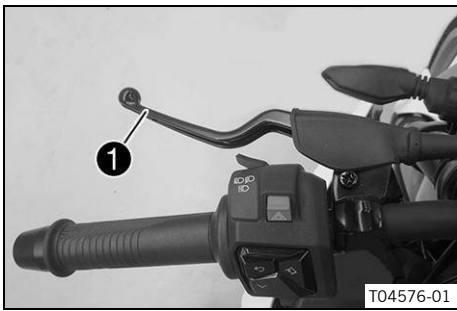

Clutch lever ❶ is fitted on the handlebar on the left.

6.2 Handbrake lever

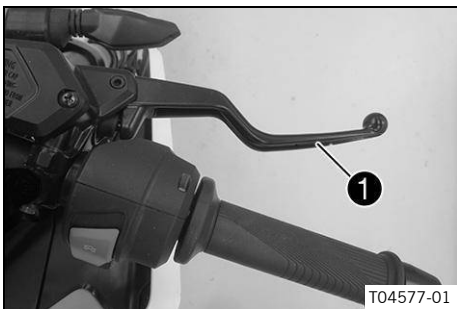

Hand brake lever ❶ is located on the right side of the handlebar. The front brake is engaged using the hand brake lever.

6.3 Throttle grip

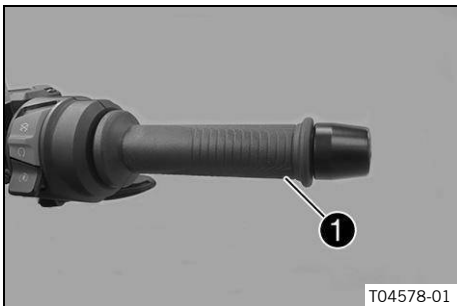

The throttle grip ❶ is fitted on the right side of the handlebar.

6.4 Combination switch

The combination switch is fitted on the left side of the handlebar.

Overview of the left combination switch

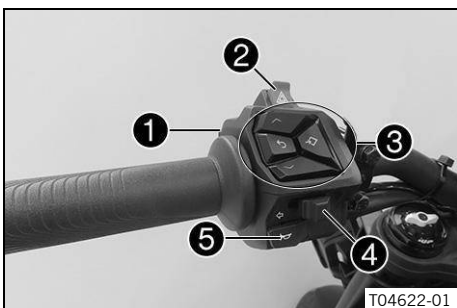

- ❶ Light switch 📖 (p. 18)
- ❷ Hazard warning flasher switch 📖 (p. 17)
- ❸ Menu buttons 📖 (p. 17)
- ❹ Turn signal switch 📖 (p. 18)
- ❺ Horn button 📖 (p. 17)

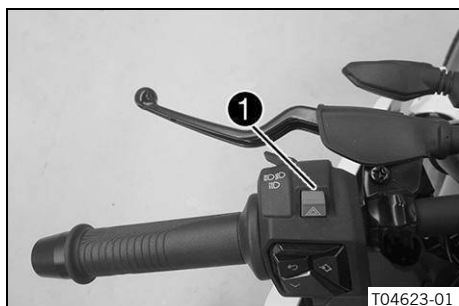

6.5 Hazard warning flasher switch

6.5.1 Hazard warning flasher switch



The hazard warning flasher switch ① is fitted on the combination switch on the left.

The hazard warning flasher is used to indicate emergency situations.

Condition	Meaning
Hazard warning flasher switch  in the basic position	No function
Hazard warning flasher switch  is pressed	All four turn signals and the green turn signal indicator lights in the combination instrument flash.

6.6 Menu buttons

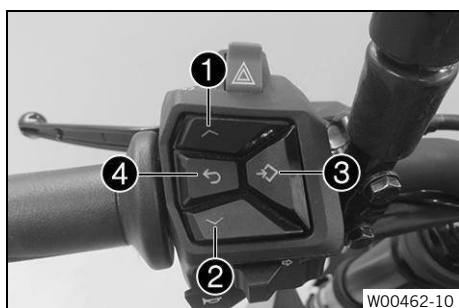

The menu buttons are fitted in the middle of the left combination switch.

The menu buttons are used to control the display on the combination instrument.

Button ① is the **UP** button.

Button ② is the **DOWN** button.



Button ③ is the **SET** button.

Button ④ is the **BACK** button.

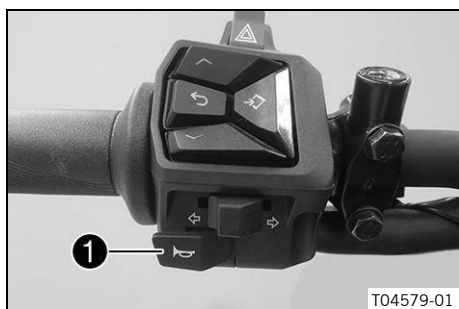
6.7 Horn button



Horn button ① is fitted on the left side of the handlebar.

Condition	Meaning
Horn button  in the basic position	No function
Horn button  pressed	The horn is operated in this position.

6.8 Light switch

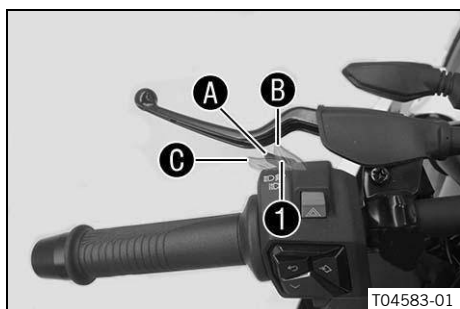

Light switch ① is fitted on the left side of the handlebar.

Condition		Meaning
	Light switch in middle position A	In this position, the low beam and the tail light are switched on.
	Light switch in position B	In this position, the high beam and the tail light are switched on.
	Light switch pulled to the handlebar C	The headlight flasher is operated in this position.

6.9 Turn signal switch

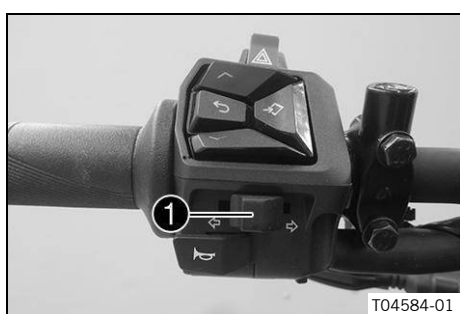

Turn signal switch ① is fitted on the left side of the handlebar.

Condition		Meaning
	Turn signal switch pressed to the left.	Left turn signal on.
	Turn signal switch pressed to the right.	Right turn signal on.

i Note

If the turn signal has been on for at least 10 seconds and the vehicle has traveled 150 meters, the turn signal is automatically switched off by a software function (**ATIR**). If the vehicle is stationary, both counters are stopped. If the turn signal switch is reactivated, both counters are reset.

6.10 Kill switch



The emergency OFF switch ① is fitted on the right side of the combination switch.

Condition		Meaning
	Emergency OFF switch off	In this position, the ignition circuit is interrupted, a running engine stops, and cannot be started. A message appears on the display.
	Emergency OFF switch on	This position is required for operation; the ignition circuit is closed.

6.11 Electric starter



Start button ① is fitted on the right side of the combination switch.

Condition		Meaning
	Electric starter in the basic position	No function
	Electric starter pressed	In this position, the starter motor is actuated.

6.12 Ignition and steering lock



The ignition and steering lock is located in front of the upper triple clamp.

Condition		Meaning
	Ignition off OFF	In this position, the ignition circuit is interrupted, a running engine stops, and an engine at a standstill will not start. The ignition key can be removed.
	Ignition on ON	In this position, the ignition circuit is closed, and the engine can be started.
	Steering locked	In this position, the ignition circuit is interrupted and the steering locked. The ignition key can be removed.

6.13 USB socket



The USB-C socket ① for the power supply to external devices is fitted on the left-hand side of the mask support.
The USB-C socket is switched on with the ignition.

USB socket	
Voltage	5 V
Maximum current consumption	2.1 A

6.14 Locking the steering



NOTE

Material damage The vehicle may be damaged if parked incorrectly. Damage can occur if the vehicle rolls away or falls over.

The components for parking the vehicle are designed only for the weight of the vehicle.

- Park the vehicle on a firm and level surface.
- Make sure that nobody sits on the vehicle when it is parked on a stand.

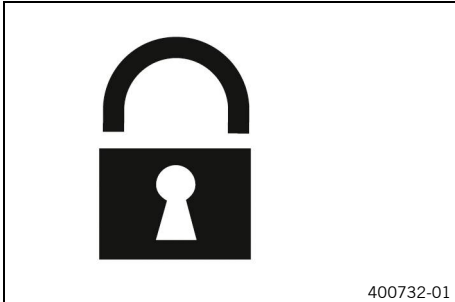

- Park the vehicle.
- Turn the handlebar all the way to the left.
- Insert the ignition key into the ignition and steering lock, press in, and turn to the left. Remove the ignition key.
- ✓ Steering is no longer possible.

6.15 Unlocking the steering

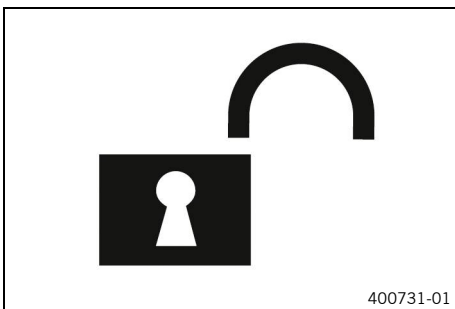

- Insert the ignition key into the ignition and steering lock, press in, and turn to the right. Remove the ignition key.
- ✓ The handlebar can now be moved again.

6.16 Opening the fuel tank cap



DANGER

Fire hazard Fuel is highly flammable.

The fuel in the fuel tank expands when warm and can escape if overfilled.

- Do not refuel the vehicle in the vicinity of open flames, glowing, or smoldering objects.
- Make sure that nobody smokes in the vicinity of the vehicle during the refueling process.
- Switch off the engine for refueling.
- Make sure that no fuel is spilled; particularly not on hot parts of the vehicle.
- If any fuel is spilled, wipe it up immediately.
- Do not overfill the fuel tank.



WARNING

Danger of poisoning Fuel is harmful to health.

- Do not allow fuel to come into contact with skin, eyes, or clothing.
- Consult a doctor immediately if fuel has been ingested.
- Do not inhale fuel vapors.
- Rinse the affected area immediately with plenty of water in the event of contact with skin.
- Rinse eyes thoroughly with water and consult a doctor immediately if fuel comes into contact with eyes.

- If fuel spills on to your clothing, change the clothing.
- Store fuel properly in a suitable container and keep out of the reach of children.



NOTE

Environmental hazard Improper handling of fuel is dangerous to the environment.

- Do not allow fuel to enter the groundwater, the soil, or the sewage system.

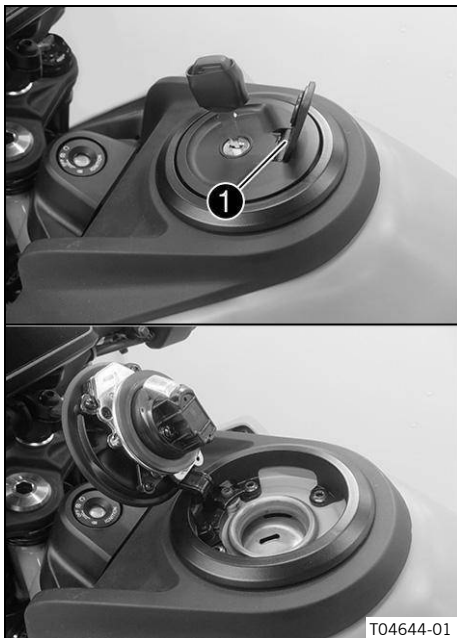

- Lift cover **1** of the fuel tank filler cap and insert the ignition key into the lock.



NOTE

Danger of damage The ignition key may break if overloaded.

- Push down on the fuel tank filler cap to take pressure off the ignition key.

- Turn the ignition key 90° clockwise.
- Lift the fuel tank filler cap.
- Remove the ignition key.

6.17 Closing the fuel tank cap

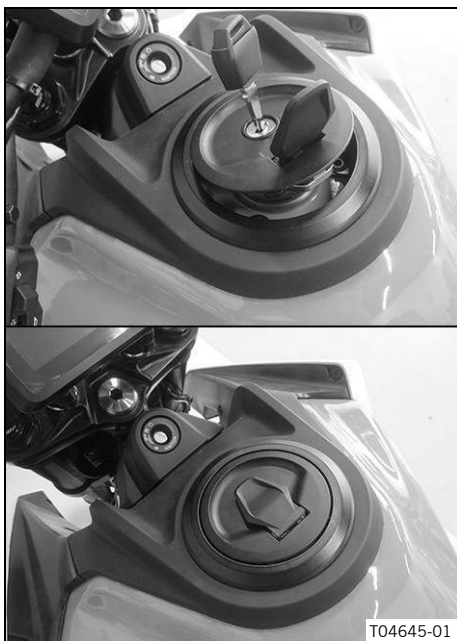

WARNING

Fire hazard Fuel is highly flammable and a health hazard.

- Check that the fuel tank filler cap is locked correctly after closing.
- If fuel spills on to your clothing, change the clothing.
- Rinse the affected area immediately with plenty of water in the event of contact with skin.

- Insert the ignition key into the lock.
- Close the fuel tank filler cap.
- Turn the ignition key 90° clockwise.
- Push down the fuel tank filler cap until the lock engages.
- Remove the ignition key.

6.18 Seat lock

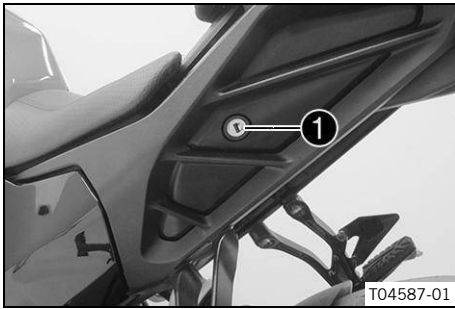

The seat lock ❶ is located to the left of the seat. The seat lock can be locked with the ignition key.

6.19 On-board tool kit

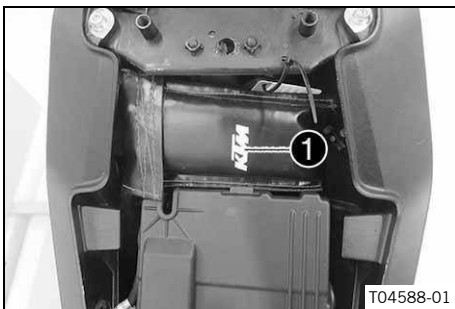

The on-board tool kit ❶ is located under the rider's seat.

6.20 Passenger strap



Supporting strap ❶ is used for maneuvering the motorcycle. If you carry a passenger, the passenger can hold onto the grab handles during the trip.

6.21 Passenger footpegs

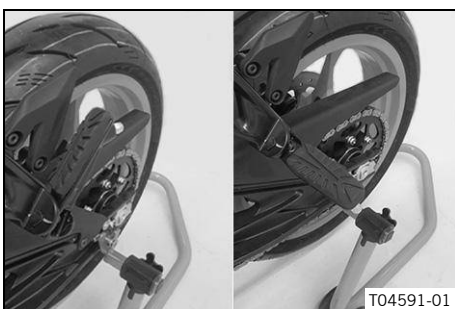

The passenger foot pegs can be folded up and down.

Condition	Meaning
Passenger foot pegs folded up	For operation without a passenger (solo).
Passenger foot pegs folded down	For operation with a passenger.

6.22 Gear shift lever

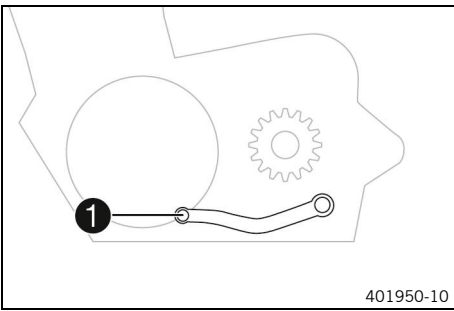

Shift lever ① is mounted on the left of the engine.

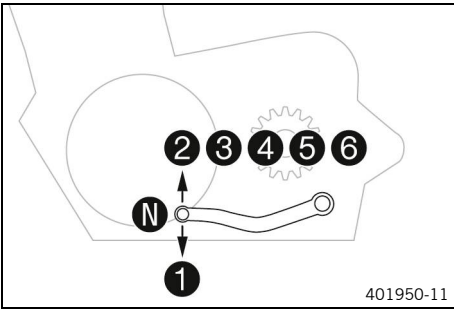

The gear positions can be seen in the figure.
The neutral or idle position is between the first and second gears.

6.23 Brake pedal

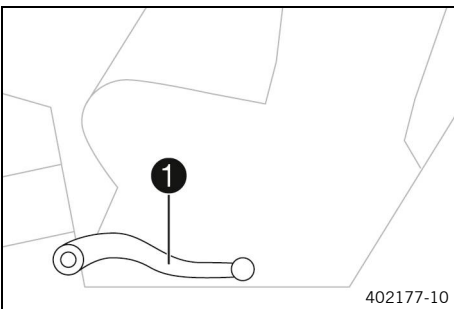

Foot brake lever ① is located in front of the right footrest.
The rear brake is operated with the brake pedal.

6.24 Side stand

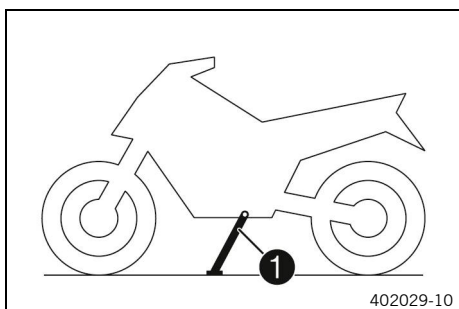

The side stand ❶ is located on the left of the vehicle.
The side stand is used for parking the motorcycle.

Condition	Meaning
Side stand folded out	The vehicle can be supported on the side stand. The safety starting system is active.
Side stand folded in	This position is mandatory when riding the motorcycle. The safety starting system is inactive.

i Note

The side stand must be folded up during motorcycle use.
The side stand is coupled with the safety starting system.
See the instructions in the section on “Stopping, parking”.

7.1 Combination instrument

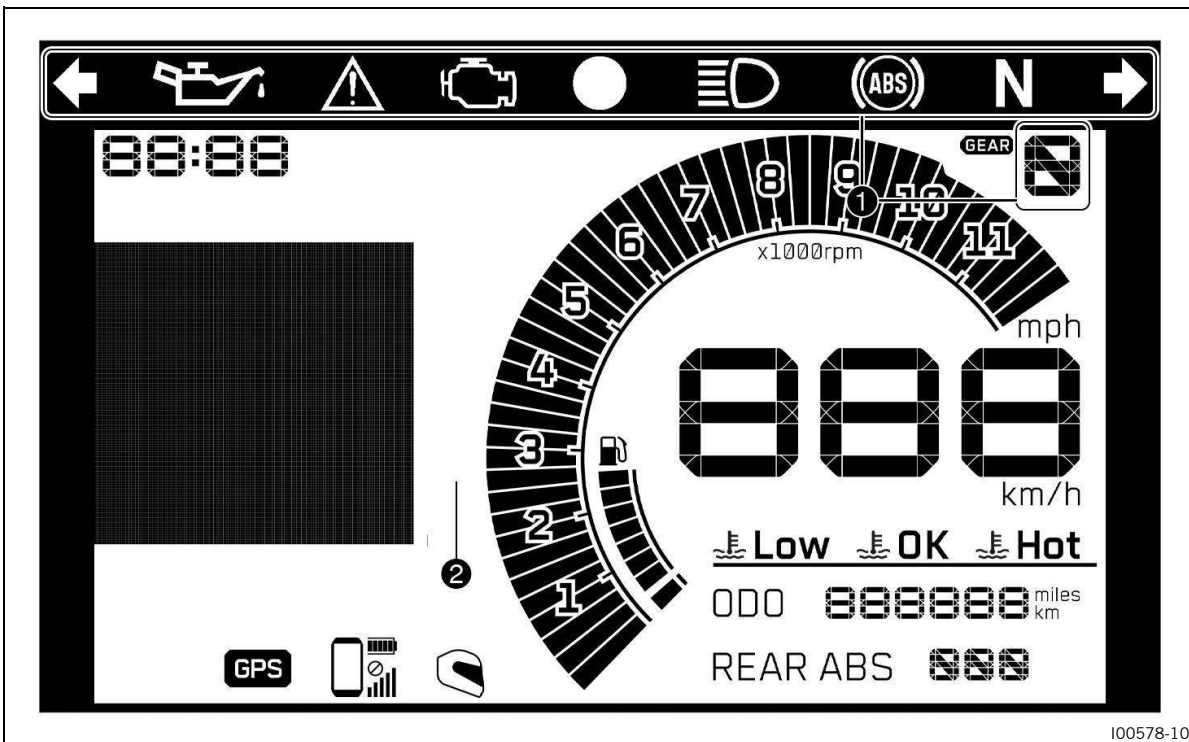

The combination instrument is attached in front of the handlebar.
The combination instrument is divided into two function areas.

- ① indicator lamps (p. 26)
- Display ②

CAUTION
Danger of burns Parts of the combination instrument become hot in certain situations. The display in particular can heat up considerably at ambient temperatures above 55 °C (131 °F) during long periods of inactivity, e.g. at traffic lights, or in direct sunlight.

- Do not touch the combination instrument with bare hands in the situations referred to.
- Where appropriate protective clothing.
- In the event of burns, rinse the area affected immediately with lukewarm water.

7.2 activation and testing

7.2.1 Activation

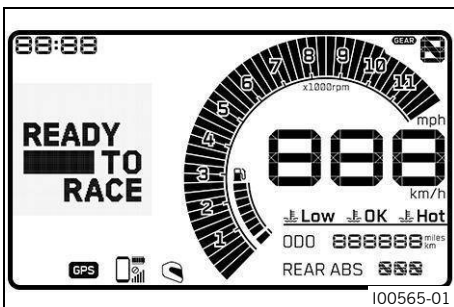

The dashboard is switched on with the ignition.



Note
The brightness of the displays is controlled by an ambient light sensor in the combination instrument.



7 Combination instrument

7.2.2 Test

The welcome text appears on the display and all the indicator lights are briefly activated for a function check.

i Note

The malfunction indicator lamp  always lights up as long as the engine is not running. If the engine is running and the failure indicator light  lights up, stop (taking care not to endanger yourself or other road users in the process) and contact an authorized dealer.

The oil pressure warning lamp  always lights up as long as the engine is not running. If the engine is running and the oil pressure warning lamp  lights up, stop immediately (taking care not to endanger yourself or other road users in the process) and switch off the engine.

The ABS warning lamp  lights up until a speed of approx. 6 km/h (approx. 4 mph) or more has been reached.

7.3 warnings

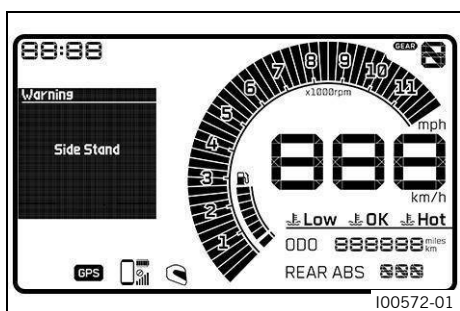

Warnings appear on the left-hand side of the display.

i Note

Warnings can be hidden by pressing any button.



All the existing warnings are displayed in the **Warning** sub-menu until they are no longer active.

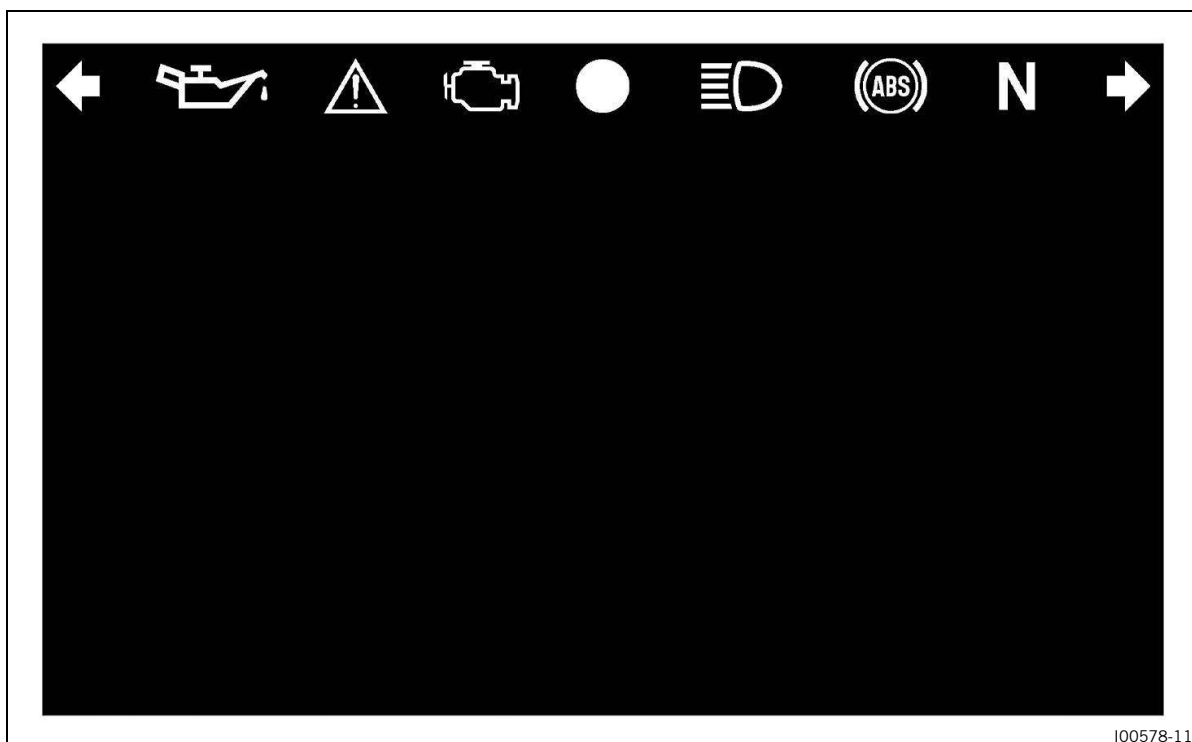

7.4 indicator lamps











The indicator lamps offer additional information about the operating state of the motorcycle. When the ignition is switched on, all indicator lamps light up briefly.

i Note

The malfunction indicator lamp  always lights up as long as the engine is not running. If the engine is running and the failure indicator light  lights up, stop (taking care not to endanger yourself or other road users in the process) and contact an authorized dealer.

The oil pressure warning lamp  always lights up as long as the engine is not running. If the engine is running and the oil pressure warning lamp  lights up, stop immediately (taking care not to endanger yourself or other road users in the process) and switch off the engine.

The ABS warning lamp  lights up until a speed of approx. 6 km/h (approx. 4 mph) or more has been reached.

Condition		Meaning
	The turn signal indicator light flashes green with a steady blinking interval	The turn signal is switched on.
	The malfunction indicator light lights up yellow	The OBD has detected a malfunction in the vehicle electronics. Come safely to a halt, and contact an authorized dealer.
	ABS warning light lights up yellow	Status or error messages relating to ABS .
	The idle indicator lamp lights up green	The transmission is in the neutral position.
	The oil pressure warning light lights up red	The oil pressure is too low. Stop immediately, taking care not to endanger yourself or other road users in the process, and switch off the engine.
	The alarm system indicator lamp lights up or flashes red	Status or error message of the alarm system.
	The high beam indicator lamp lights up blue	The high beam is switched on.
	General warning light lights up yellow	A note/warning note on operating safety has been detected. This is also shown in the display.

7 Combination instrument

7.5 Display

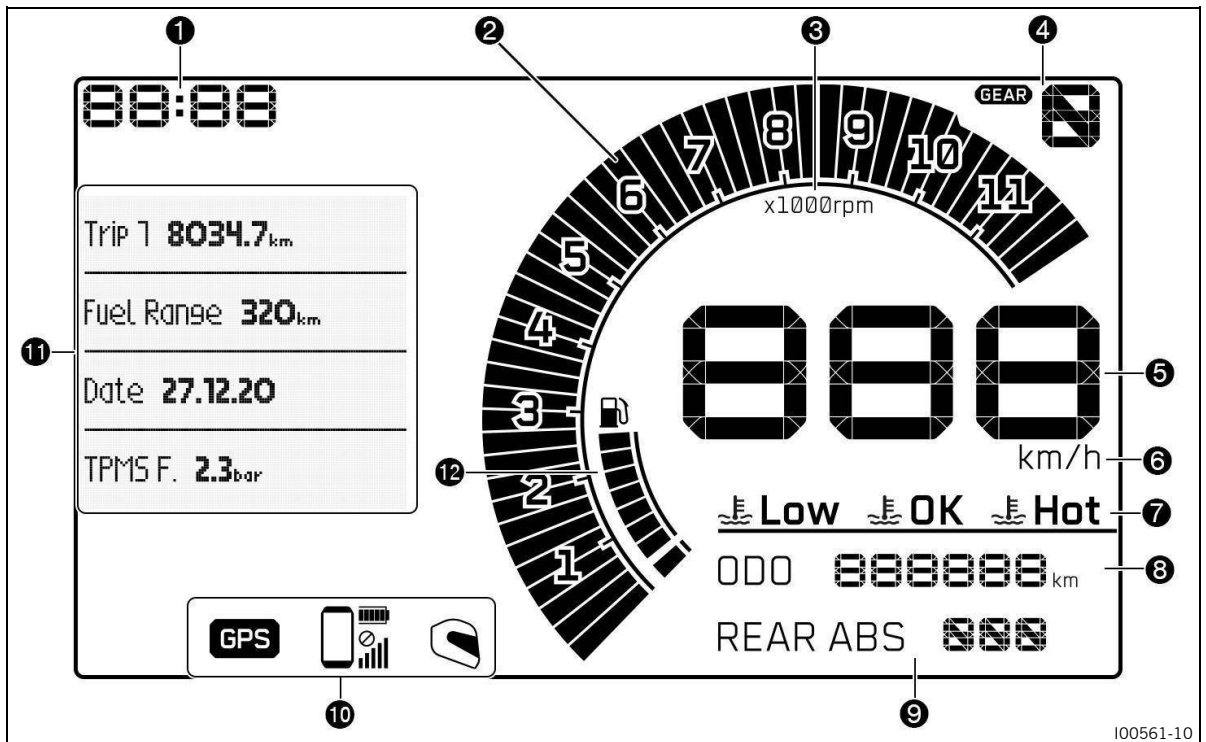

100561-10

- | | |
|--|---|
| <ul style="list-style-type: none"> ① time (p. 29) ② speed (p. 28) ② shift light (p. 29)
The shift light is integrated in the rpm gauge display. ③ Unit for the engine speed display ④ Gear display ⑤ speed display (p. 29) | <ul style="list-style-type: none"> ⑥ Unit of speed ⑦ coolant temperature indicator (p. 30) ⑧ Odometer ⑨ ABS display (p. 30) ⑩ Connected devices ⑪ Favorites display (p. 31) ⑫ fuel level display (p. 31) |
|--|---|

7.6 speed

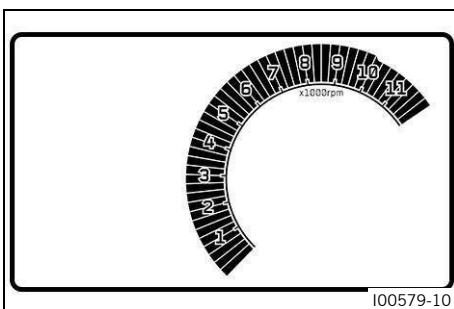

100579-10

The engine speed is displayed in revolutions per minute.

7.7 shift light

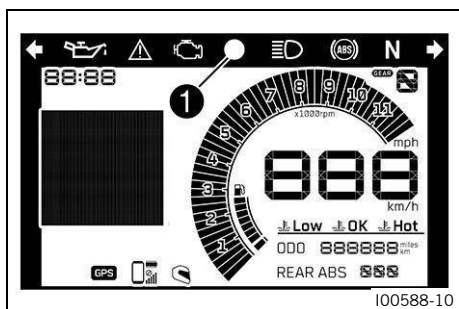

LED ① is used as a shift warning light.

In the **Shift Light** submenu, the engine speed for the shift warning light can be set. During the run-in time (up to 1000 km / 621 miles), the shift light is always active. The shift warning light can only be deactivated, and the values for **RPM1** and **RPM2** can only be adjusted after this. With **RPM1**, LED ① flashes; and with **RPM2**, LED ① lights up continuously.

Note

After the first service, the shift warning light is deactivated when the engine is warm and in sixth-gear.

Coolant temperature	≤ 35 °C (≤ 95.0 °F)
ODO	< 1,000 km (< 621.4 mi)
The shift warning light always flashes at	6,500 rpm (108.33 Hz)

Coolant temperature	> 35 °C (> 95.0 °F)
ODO	> 1,000 km (> 621.4 mi)
RPM1 shift warning light	flashes
RPM2 shift warning light	Lights up continuously.

7.8 speed display

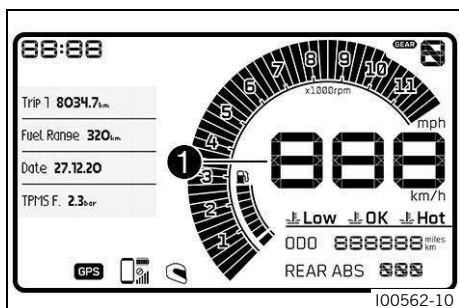

The speed is shown in area ① of the display.

Speed is shown in kilometers per hour **km/h** or in miles per hour **mph**.

The unit of speed can be configured in the **Distance** submenu.

7.9 time

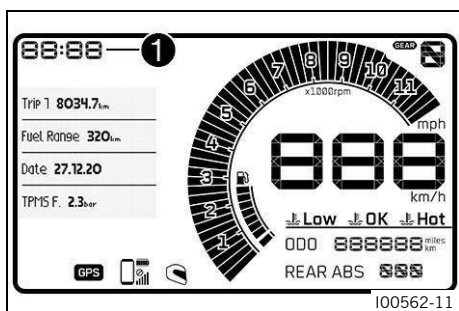

The time is shown in area ① of the display.

Note

The time must be reset if the 12 V battery was disconnected from the vehicle or the fuse was removed.

7.10 ABS display

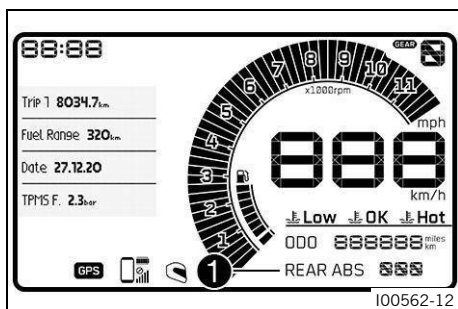

The ABS mode setting is shown in the ❶ area of the display. ABS can be configured separately in the **ABS** submenu.

i Note

When the ABS mode **Road** is active, ABS controls both wheels.

When the **Supermoto** ABS mode is active, ABS only controls the front wheel. The rear wheel is not controlled by ABS and may lock during braking maneuvers.

7.11 coolant temperature indicator

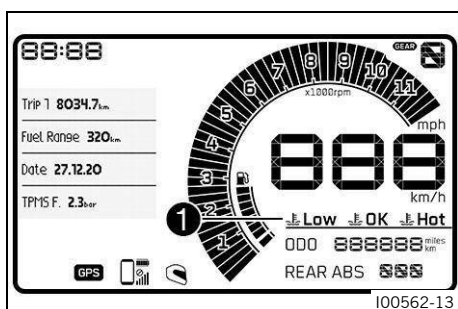

The coolant temperature is displayed by a symbol ❶. The symbol changes between **LOW**, **OK** and **HOT** depending on the temperature.

⚙ NOTE

Engine failure Overheating damages the engine.

- If the coolant temperature warning is displayed, stop immediately and take care not to endanger yourself or other traffic participants in the process.
- Allow the engine and cooling system to cool down.
- Check and, if necessary, correct the coolant level on the cooling system while it is in a cooled state.

i Note

If the coolant temperature indicator ❶ is showing **HOT**, the indicator also starts to flash.

If the cooling system overheats, the maximum engine speed is limited.

Condition	Meaning
The coolant temperature indicator ❶ shows LOW .	The engine is cold
The coolant temperature indicator ❶ shows OK .	Engine warm
The coolant temperature indicator ❶ shows HOT .	Engine hot

7.12 fuel level display

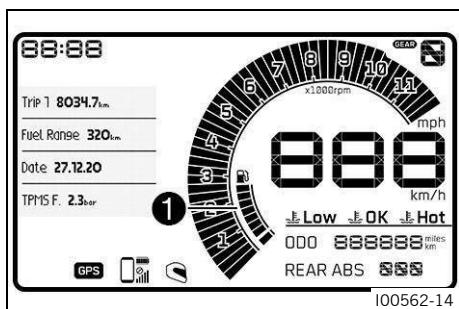

Fuel level display ❶ consists of a bar. The higher the bar is filled, the more fuel there is in the fuel tank.



Note

If the fuel level is getting low, the last segment flashes and the **LOW FUEL** warning also appears.

The fuel level is displayed with a slight delay to prevent the indicator from constantly moving while riding.

Fuel level display ❶ is not updated while the side stand is folded out or the emergency OFF switch is switched off.

Once the side stand is folded up and the kill switch is switched on, the fuel level display is next updated after 2 minutes.

The fuel level display flashes if the combination instrument does not receive a signal from the fuel level sensor.

7.13 Favorites display

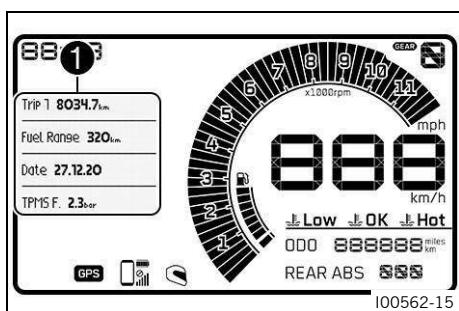

Up to four items of information are displayed in the **Favorites** display ❶.

The **Favorites** display can be freely configured in the **Favorites** sub-menu.

7.14 Quick Selector 1 display

When the menu is closed, the **Quick Selector 1** display is opened by pressing the **UP** button. Press the **BACK** button to close the **Quick Selector 1** display.



Note

The **Quick Selector 1** display can be configured in the **Settings** menu under **Quick Selector 1**. Any information can be selected.

7.15 Quick Selector 2 display

When the menu is closed, the **Quick Selector 2** display is opened by pressing the **DOWN** button. Press the **BACK** button to close the **Quick Selector 2** display.



Note

The **Quick Selector 2** display can be configured in the **Settings** menu under **Quick Selector 2**. Any information can be selected.

7.16 Navigation display (optional)

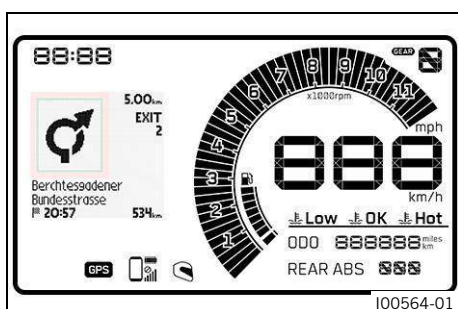

The **Navigation** indicator (optional) appears when the navigation function is activated.

In the **Navigation** display (optional), the direction arrow, the distance from the destination, the estimated arrival time of the cell phone, the distance to the next waypoint, and the street name are displayed.

The **Navigation** display (optional) can be switched on or off in the **Navigation** submenu (optional).

Conditions for use:

- The dashboard is connected to a suitable cell phone.
- The **KTMconnect** app (optional) is installed and connected on a suitable cell phone (Android devices from version 7.0, iOS devices from version 14).

7.17 Call display

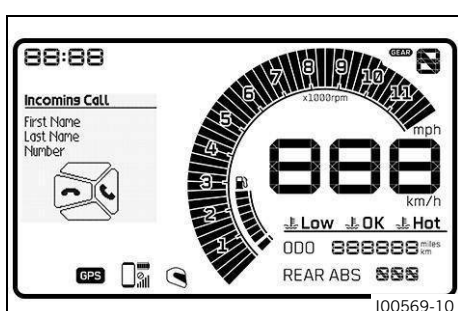

WARNING

Danger of accidents Headphone volume which is too high distracts attention from traffic activity.

- Always select headphone volume which is low enough for you to still clearly hear acoustic signals.

The **Call** indicator appears for incoming or active calls.

Press the **SET** button to accept an incoming call.

Press the **BACK** button to reject an incoming call.

Press the **UP** button to increase the audio volume.

Press the **DOWN** button to reduce the audio volume.



Note

It is not possible to change the audio volume using the combination switch with every cell phone.

The call duration and contact are displayed. Depending on the cell phone settings, the contact is shown by name.

You cannot navigate in the menu during an active phone conversation.

Condition for use:

- The dashboard is connected to a suitable cell phone.

7.18 Remote Control Mode (optional)

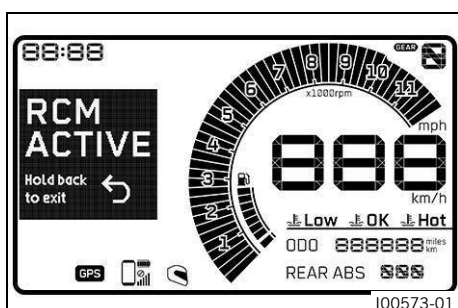

The **Remote Control Mode** indicator (optional) appears when **Remote Control Mode** is activated.

Pressing the **BACK** button for approx. 3 seconds activates the **Remote Control Mode** (optional).

Pressing the **BACK** button for approx. 3 seconds exits the **Remote Control Mode** (optional).

If **Remote Control Mode** (optional) is activated, you can navigate using the combination switch in the app on a cell phone.



Note

In **Remote Control Mode** (optional), you can only navigate within the app.

If **Remote Control Mode** (optional) is active, you cannot navigate in the combination instrument.

Remote Control Mode (optional) cannot be activated when a menu is open.

Conditions for use:

- The dashboard is connected to a suitable cell phone.
- The **KTMconnect** app (optional) must be installed, connected and opened on a suitable cell phone (Android devices from version 7.0, iOS devices from version 14).

7.19 Menu

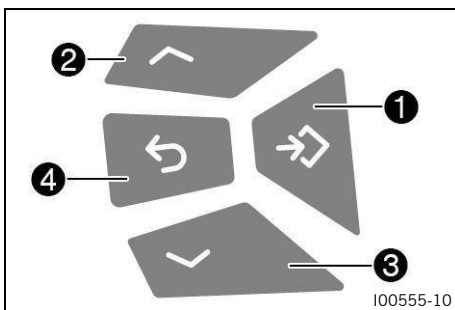

Note

Press the **SET** button ① in the start screen to open the menu.

Navigate through the menu using the **UP** button ② or the **DOWN** button ③.

By pressing the **BACK** button ④, the menu structure jumps one step back, or the menu is closed.

7.19.1 ABS

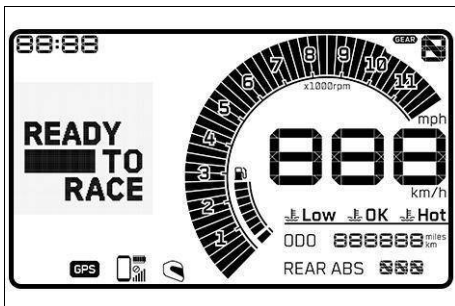

- Press the **SET** button when the menu is closed.
- Press the **UP** or **DOWN** button until **ABS** is highlighted. Press the **SET** button to open the menu.
- Activate the menu item using the **UP** or **DOWN** button.



WARNING

Danger of accidents An incorrectly selected ABS mode makes it more difficult to control the vehicle.

The ABS modes are each only suitable for certain conditions.

- Always select an ABS mode that suits the ground and the riding situation.

- Press the **SET** button to select the desired ABS mode.

Do not open the throttle during the selection.



Note

The ABS mode can be switched during the journey.

When the ABS mode **Road** is active, ABS controls both wheels.

When the **Supermoto** ABS mode is active, ABS only controls the front wheel. The rear wheel is no longer controlled by ABS and may lock during braking maneuvers.

7 Combination instrument

7.19.2 Bike info

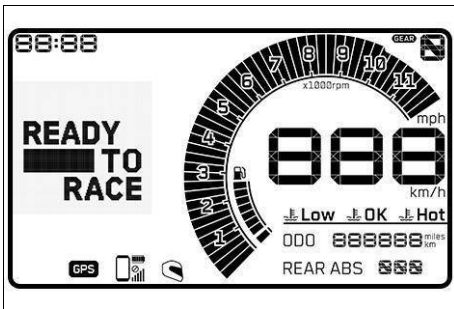

- Press the **SET** button when the menu is closed.
- Press the **UP** or **DOWN** button until **Bike Info** is highlighted. Pressing the **SET** button opens the menu.

General information and warnings that may be present can be called up in **Bike Info**.

7.19.3 Bike info

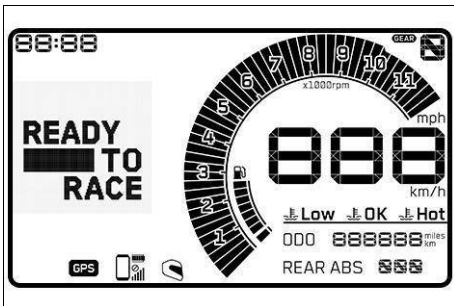

- Press the **SET** button when the menu is closed.
- Press the **UP** or **DOWN** button until **Bike Info** is highlighted. Press the **SET** button to open the menu.

Engine Temperature displays the coolant temperature.

Fuel Range indicates the possible fuel range you can cover with the fuel reserve.

Battery displays the battery voltage.

Odometer displays the total mileage.

Service displays when the next service is due.

Warnings displays warnings that have occurred until they are no longer active.

7.19.4 Warning

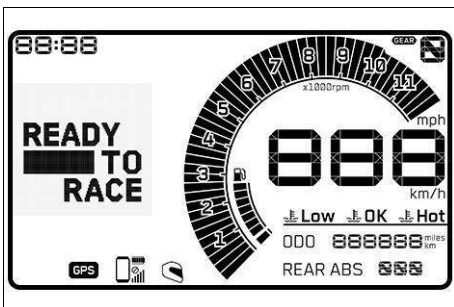

Condition: Message or warning is present

- Press the **SET** button when the menu is closed.
- Press the **UP** or **DOWN** button until **Bike Info** is highlighted. Pressing the **SET** button opens the menu.
- Press the **UP** or **DOWN** button until **Warning** is highlighted. Press the **SET** button to open the submenu.
- Use the **UP** or **DOWN** button to navigate through the warnings.

i Note

The warnings that have occurred are saved in the display until they are no longer active.

7.19.5 Trip info

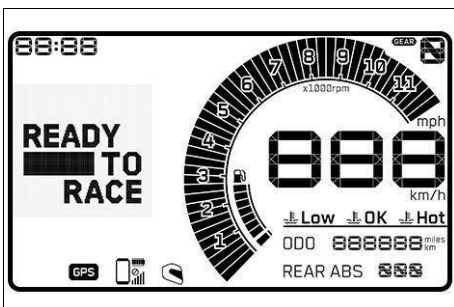

- Press the **SET** button when the menu is closed.
- Press the **UP** or **DOWN** button until **Trip** is highlighted. Pressing the **SET** button opens the menu.

General information on the distance traveled, trip time, average fuel consumption, and average speed can be accessed in menu **Trip**.

7.19.6 Trip 1

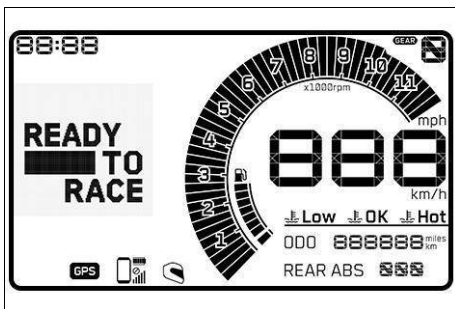

- Press the **SET** button when the menu is closed.
- Press the **UP** or **DOWN** button until **Trip** is highlighted. Press **SET** button to open the menu.
- Press the **UP** or **DOWN** button until **Trip 1** is highlighted. Press the **SET** button to open the submenu.

Information on **Trip 1** can be viewed in the **Trip 1** submenu.

i Note

Trip displays the distance since the last reset, e.g. between two refueling stops. **Trip** runs along and counts to **9999**.

Trip Time shows the riding time on the basis of **Trip** and runs as soon as a speed signal is received.

ØConsump. indicates the average fuel consumption based on **Trip**.

ØSpeed indicates the average speed based on **Trip** and **Trip Time**.

Press **Reset Trip** to reset all entries in the **Trip 1** menu.

7.19.7 Trip 2

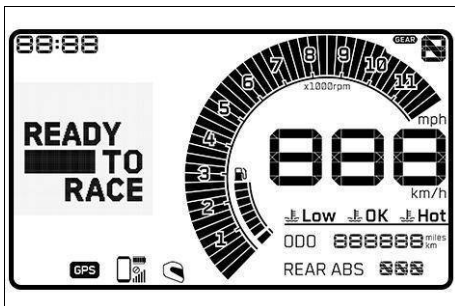

- Press the **SET** button when the menu is closed.
- Press the **UP** or **DOWN** button until **Trip** is highlighted. Press **SET** button to open the menu.
- Press the **UP** or **DOWN** button until **Trip 2** is highlighted. Press the **SET** button to open the submenu.

Information on **Trip 2** can be viewed in the **Trip 2** submenu.

i Note

Trip displays the distance since the last reset, e.g. between two refueling stops. **Trip** runs along and counts to **9999**.

Trip Time shows the riding time on the basis of **Trip** and runs as soon as a speed signal is received.

ØConsump. indicates the average fuel consumption based on **Trip**.

ØSpeed indicates the average speed based on **Trip** and **Trip Time**.

Press **Reset Trip** to reset all entries in the **Trip 2** menu.

7.19.8 Navigation (optional)

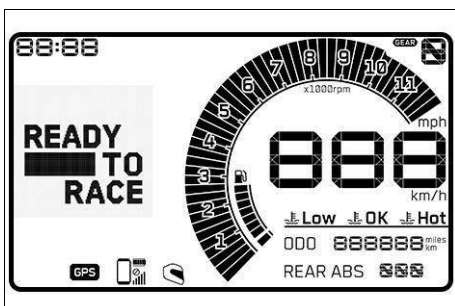

Condition: Function **Bluetooth®** activated, The **KTMconnect** app (optional) is installed and connected on a suitable cell phone (Android devices from version 7.0, iOS devices from version 14), The combination instrument is connected to a suitable cell phone, GPS function is activated on the connected cell phone, Voice navigation: The dashboard is connected to a suitable communication system and an appropriate language package has been downloaded in the **KTMconnect Navigation** app (optional)

- Press the **SET** button when the menu is closed.
- Press the **UP** or **DOWN** button until **Navigation** is marked. Pressing the **SET** button opens the menu.

7.19.9 Volume (optional)

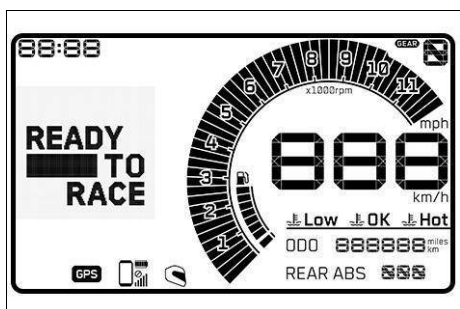

Condition: The **KTMconnect** app (optional) is installed and connected on a suitable cell phone (Android devices from version 7.0, iOS devices from version 14), The combination instrument is connected to a suitable cell phone, Voice navigation: The dashboard is connected to a suitable communication system and an appropriate language package has been downloaded in the **KTMconnect** app (optional)

- Press the **SET** button when the menu is closed.
- Press the **UP** or **DOWN** button until **Navigation** is marked. Pressing the **SET** button opens the menu.



WARNING

Danger of accidents Headphone volume which is too high distracts attention from traffic activity.

- Always select headphone volume which is low enough for you to still clearly hear acoustic signals.

- Press the **UP** or **DOWN** button until **Volume** is marked. Press the **SET** button to open the submenu.
- Press the **UP** button to increase the volume of the activated voice navigation.
- Press the **DOWN** button to reduce the volume of the activated voice navigation.

7.19.10 start/stop navigation (optional)

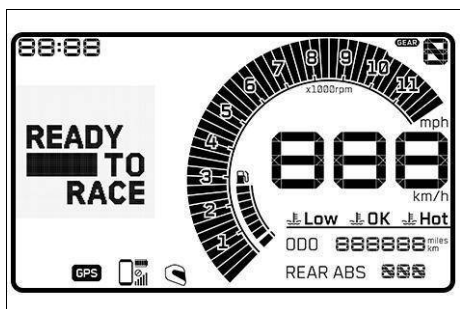

Condition: Function **Bluetooth®** activated, The **KTMconnect** app (optional) is installed and opened on a suitable cell phone (Android devices from version 7.0, iOS devices from version 14), The combination instrument is connected to a suitable cell phone

- Press the **SET** button when the menu is closed.
- Press the **UP** or **DOWN** button until **Navigation** is marked. Pressing the **SET** button opens the menu.
- Press the **UP** or **DOWN** button until **Start/Stop Navigation** is marked. Press the **SET** button to confirm the selection.
- Press the **SET** button to switch the visual navigation on or off.

i Note

Voice navigation remains switched on if it has been activated.

The volume of the activated voice navigation is identical to the volume of the audio player on the cell phone. If the volume on the cell phone is changed, the volume of the activated voice navigation also changes.

7.19.11 Audio

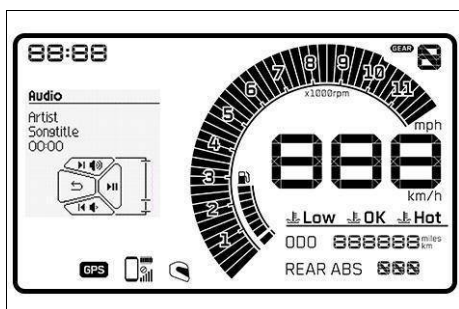

Condition: Function **Bluetooth**® activated, The dashboard is connected to a suitable cell phone., The dashboard is connected to a suitable communication system or the **Headset Type Corded** is selected

- Press the **SET** button when the menu is closed.



WARNING

Danger of accidents Headphone volume which is too high distracts attention from traffic activity.

- Always select headphone volume which is low enough for you to still clearly hear acoustic signals.

- Press the **UP** or **DOWN** button until **Audio** is highlighted. Press **SET** button to open the menu.
- Press and hold **UP** button to increase the audio volume.
- Press and hold **DOWN** button to reduce the audio volume.
- Press **UP** button briefly to change to the next audio track.
- Briefly pressing the **DOWN** button once or twice replays the current audio track from the start or changes to the previous audio track, depending on the cell phone.
- Press **SET** button to play or pause the audio track.



Note

With some cell phones, the cell phone audio player needs to be started before playback is possible.

The audio function can be added to **Quick Selector 1** or **Quick Selector 2** for easier operation.

7.19.12 Lap timer

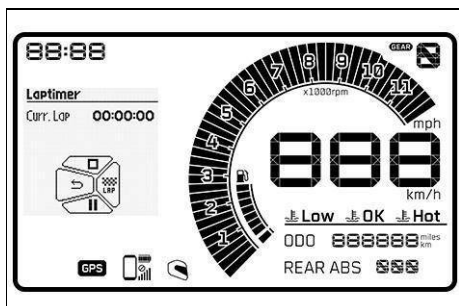

- Press the **SET** button when the menu is closed.
- Press the **UP** or **DOWN** button until **Lap Timer** is highlighted. Pressing the **SET** button opens the menu.

The timed laps can be displayed in the **Lap Timer** menu.

7 Combination instrument

7.19.13 Delete All Rounds

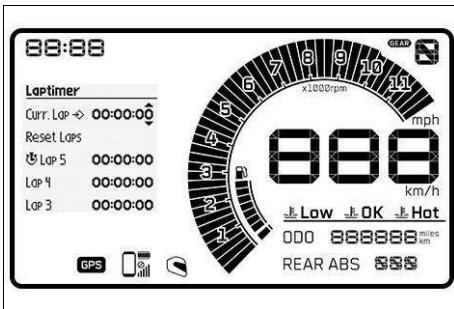

- Press the **SET** button when the menu is closed.
- Press the **UP** or **DOWN** button until **Lap Timer** is highlighted. Pressing the **SET** button opens the menu.
- Press the **UP** or **DOWN** button until **Reset Laps** is highlighted. Press the **SET** button to delete all saved laps.

7.19.14 Settings

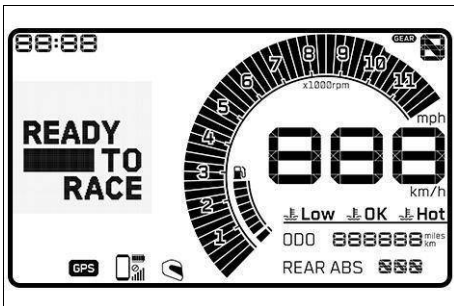

Condition: Motorcycle is stationary

- Press the **SET** button when the menu is closed.
- Press the **UP** or **DOWN** button until **Settings** is highlighted. Pressing the **SET** button opens the menu.

In menu **Settings**, favorites, quick selections, **Connectivity** (optional), and the shift light can be configured. Settings can be made for units or various values. Several functions can be enabled or disabled.

7.19.15 favorites

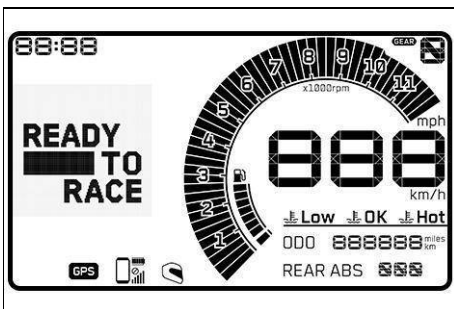

Condition: Motorcycle is stationary

- Press the **SET** button when the menu is closed.
- Press the **UP** or **DOWN** button until **Settings** is highlighted.
- Press the **SET** button to open the menu.
- Press the **UP** or **DOWN** button until “Favorites” is highlighted. Press the **SET** button to open the submenu.
- Access menu item with the **UP** or **DOWN** button, and add the selected information to the Favorites display using the **SET** button.

Up to four sets of information can be selected in the **Favorites** menu.

7.19.16 Quick selector 1

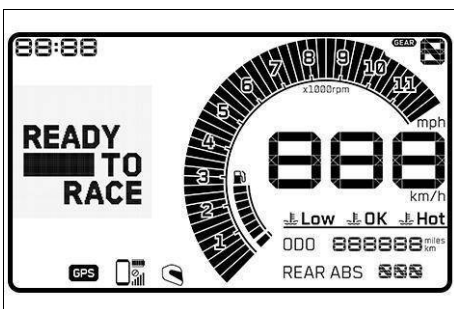

Condition: Motorcycle is stationary

- Press the **SET** button when the menu is closed.
- Press the **UP** or **DOWN** button until **Settings** is highlighted.
- Press the **SET** button to open the menu.
- Press the **UP** or **DOWN** button until **Quick Selector 1** is highlighted. Press the **SET** button to open the submenu.
- Activate the menu item using the **UP** or **DOWN** button.
- Press the **SET** button to set a direct selection submenu for **Quick Selector 1**.



Note

When the menu is closed, the submenu defined in **UP** is opened by pressing the **Quick Selector 1** button.

7.19.17 Quick selector 2

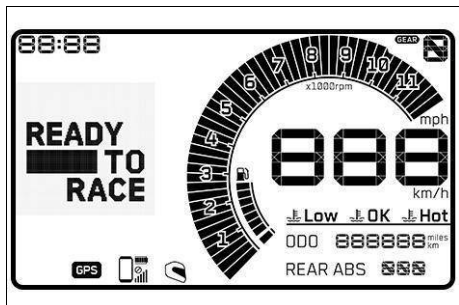

Condition: Motorcycle is stationary

- Press the **SET** button when the menu is closed.
- Press the **UP** or **DOWN** button until **Settings** is highlighted.
- Press the **SET** button to open the menu.
- Press the **UP** or **DOWN** button until **Quick Selector 2** is highlighted. Press the **SET** button to open the submenu.
- Activate the menu item using the **UP** or **DOWN** button.
- Press the **SET** button to set a direct selection submenu for **Quick Selector 2**.



Note

When the menu is closed, the submenu defined in **DOWN** is opened by pressing the **Quick Selector 2** button.

7.19.18 connectivity

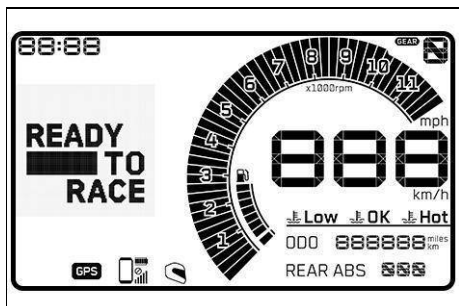

Condition: Motorcycle is stationary, Function **Bluetooth®** activated

- Press the **SET** button when the menu is closed.
- Press the **UP** or **DOWN** button until **Settings** is highlighted.
- Pressing the **SET** button opens the menu.
- Press the **UP** or **DOWN** button until **Connectivity** is highlighted. Press the **SET** button to open the submenu.

In menu **Connectivity**, an appropriate cell phone or communication system can be paired with the dashboard via **Bluetooth®** and the audio function and navigation function can be configured.



Note

Not every cell phone or communication system is suitable for pairing with the dashboard.

The standard **Bluetooth®** 4.0 must be supported.

7.19.19 Bluetooth

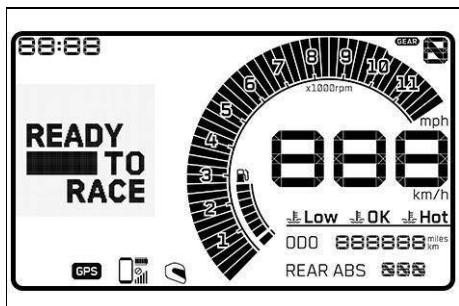

Condition: Motorcycle is stationary

- Press the **SET** button when the menu is closed.
- Press the **UP** or **DOWN** button until **Settings** is highlighted.
- Press the **SET** button to open the menu.
- Press the **UP** or **DOWN** button until **Connectivity** is highlighted. Press the **SET** button to open the submenu.
- Press the **UP** or **DOWN** button until **Bluetooth** is highlighted. Press the **SET** button to open the submenu.
- Activate the menu item using the **UP** or **DOWN** button.
- Press the **SET** button to switch the **Bluetooth®** function on or off.

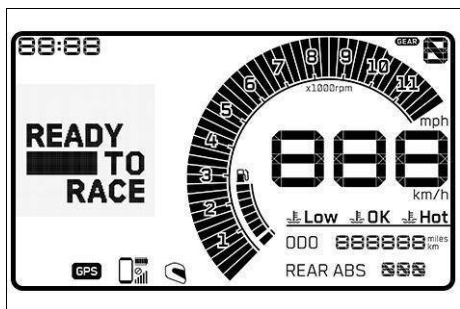

7.19.20 pairing a phone

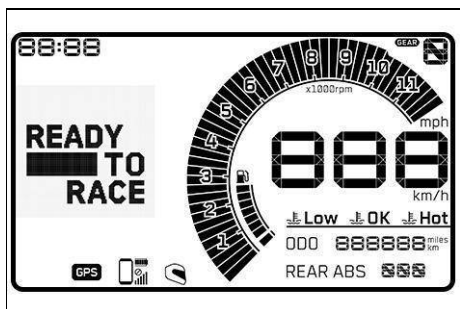

i Note
The function **Bluetooth®** must be activated to pair a suitable cell phone or communication system with the vehicle.
Not every cell phone and communication system is suitable for pairing with the combination instrument.

Condition: Motorcycle is stationary, Function **Bluetooth®** activated, Function **Bluetooth®** also activated on the device that is to be paired

- Press the **SET** button when the menu is closed.
- Press the **UP** or **DOWN** button until **Settings** is highlighted. Press the **SET** button to open the menu.
- Press the **UP** or **DOWN** button until **Connectivity** is highlighted. Press the **SET** button to open the submenu.
- Press the **UP** or **DOWN** button until "Pair phone" is highlighted. Press the **SET** button to open the submenu.

i Note
Only one cell phone can be paired with the vehicle at a time.

- Press the **UP** or **DOWN** button until **New Pairing** is marked. Press the **SET** button to open the submenu.
- The vehicle starts the search for a suitable cell phone. If the search is successful, the name of the cell phone is displayed again in the pairing menu. Press the **SET** button to start the pairing.

i Note
The cell phone must be visible via **Bluetooth®** in order for the cell phone to be found by the vehicle.
Not every cell phone is suitable for pairing with the vehicle.

- A message appears on the combination instrument indicating that the vehicle is now ready for pairing. The pairing is successfully completed by confirming the **Passkey** on the cell phone and on the dashboard.

i Note
Follow the instructions in the app when connecting with **KTMconnect**. Confirmation may be required on the combination instrument.

- Press the **UP** or **DOWN** button until "Delete pairing" is highlighted. The paired device can be deleted by pressing the **SET** button.
- Move the previously paired device into the range of the vehicle while the **Bluetooth®** function is active.
 - ✓ The device is automatically connected with the vehicle.
 - ✗ If the device is not automatically connected with the vehicle after approx. 30 seconds:

- Switch on the vehicle again or repeat the **New Pairing** procedure.

In submenu **Phone Pairing**, a suitable cell phone can be paired with the dashboard via **Bluetooth®**.

i Note

Not every cell phone and communication system is suitable for pairing with the dashboard.

Make sure the end device is in the correct pairing mode for call management. If the end device is only paired for media playback, the call function may not work.

7.19.21 headset pairing

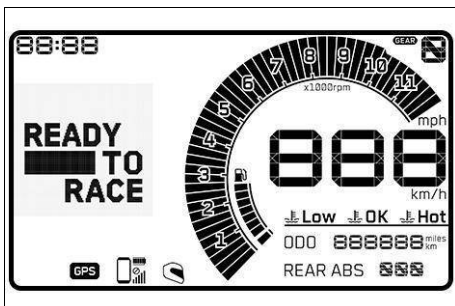

Condition: Motorcycle is stationary, Function **Bluetooth®** activated, Function **Bluetooth®** also activated on the device that is to be paired

- Press the **SET** button when the menu is closed.
- Press the **UP** or **DOWN** button until **Settings** is highlighted. Press **SET** button to open the menu.
- Press the **UP** or **DOWN** button until **Connectivity** is highlighted. Press the **SET** button to open the submenu.
- Press the **UP** or **DOWN** button until **Riders Headset** is highlighted. Press the **SET** button to open the submenu.
- Press the **UP** or **DOWN** button until **New Pairing** is marked. Press the **SET** button to open the submenu.
- The vehicle starts searching for a suitable communication system. If the search was successful, the name of the rider's audio device is displayed in the **New Pairing** submenu. Press the **SET** button to start the pairing.

i Note

The communication system must be in pairing mode for the communication system to be found by the vehicle. Follow the instructions in the communication system owner's manual.

Press the **UP** or **DOWN** button until **Delete Pairing** is highlighted. The paired device can be deleted by pressing the **SET** button.

Not every communication system is suitable for pairing with the vehicle.

- Move the previously paired device into the range of the vehicle while the **Bluetooth®** function is active.
 - ✓ The device is automatically connected with the vehicle.
 - ✗ If the device is not automatically connected with the vehicle after approx. 30 seconds:
 - Switch on the vehicle again or repeat the **New Pairing** procedure.

In the **Riders Headset** submenu, a suitable rider communication system can be paired with the vehicle.

7.19.22 Type of audio device

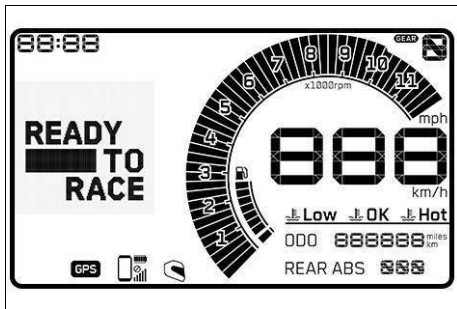

Condition: Motorcycle is stationary

- Press the **SET** button when the menu is closed.
- Press the **UP** or **DOWN** button until **Settings** is highlighted. Press **SET** button to open the menu.
- Press the **UP** or **DOWN** button until **Connectivity** is highlighted. Press the **SET** button to open the submenu.
- Press the **UP** or **DOWN** button until **Headset Type** is highlighted.
- Activate the menu item using the **UP** or **DOWN** button.
- Press the **SET** button to change the rider audio device type.

The connection mode for the rider headset can be selected in the **Headset Type** menu.

The communication system is connected to the vehicle wirelessly via **Bluetooth Headset** in **Bluetooth®** display mode.

The communication system is connected directly to the smartphone in display mode **Corded Headset**.

i Note

The **Riders Headset** menu item is only available in **Headset Type Bluetooth**.

7.19.23 QUICKSHIFTER+ (optional)

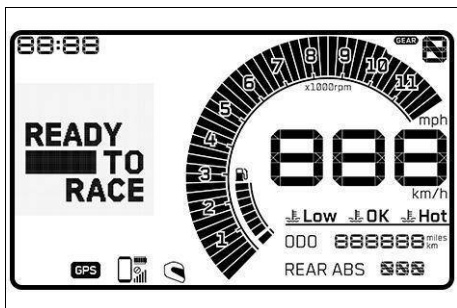

- Press the **SET** button when the menu is closed.
- Press the **UP** or **DOWN** button until **Settings** is highlighted. Pressing the **SET** button opens the menu.
- Press the **UP** or **DOWN** button until **QUICKSHIFTER+ (optional)** is highlighted. Press the **SET** button to open the submenu.
- Press the **UP** or **DOWN** button to activate or deactivate **QUICKSHIFTER+ (optional)**.

7.19.24 Shift Light

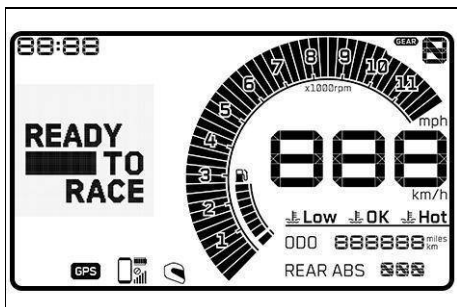

Condition: Motorcycle is stationary, **ODO** > 1000 km (621 mi)

- Press the **SET** button when the menu is closed.
- Press the **UP** or **DOWN** button until **Settings** is highlighted. Press the **SET** button to open the menu.
- Press the **UP** or **DOWN** button until **Shift Light** is highlighted. Press the **SET** button to open the submenu.

The shift warning light can be configured in the **Shift Light** submenu.

7.19.25 Shift light state

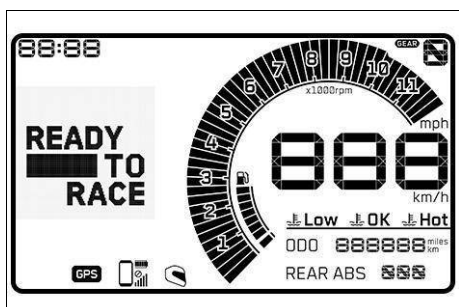

Condition: Motorcycle is stationary, **ODO** > 1000 km (621 mi)

- Press the **SET** button when the menu is closed.
- Press the **UP** or **DOWN** button until **Settings** is highlighted. Press the **SET** button to open the menu.
- Press the **UP** or **DOWN** button until **Shift Light** is highlighted. Press the **SET** button to open the submenu.
- Activate the menu item using the **UP** or **DOWN** button.
- Press the **SET** button to switch the shift warning light on or off.

7.19.26 RPM1

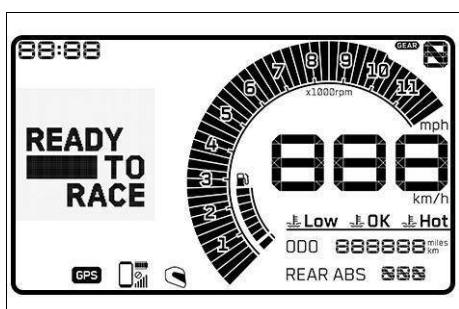

Condition: Motorcycle is stationary, **ODO** > 1000 km (621 mi)

- Press the **SET** button when the menu is closed.
- Press the **UP** or **DOWN** button until **Settings** is highlighted. Press the **SET** button to open the menu.
- Press the **UP** or **DOWN** button until **Shift Light** is highlighted. Press the **SET** button to open the submenu.
- Press the **UP** or **DOWN** button until **RPM1** is highlighted. Press the **SET** button to open the submenu.
- Activate the menu item using the **UP** or **DOWN** button.
- Set the value for **SET** by pressing the **RPM1** button.



Note

RPM1 can be set in intervals of 500 between 5,500 and 10,000 rpm.

RPM1 must not be larger than **RPM2**.

If the engine speed reaches the set value **RPM1**, the shift warning light flashes.

7.19.27 RPM2

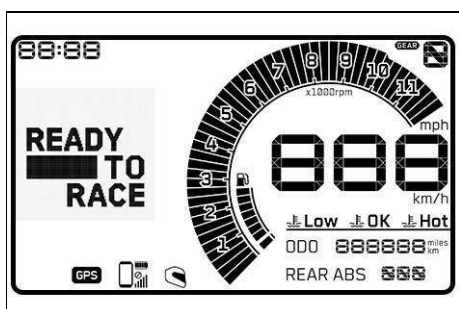

Condition: Motorcycle is stationary, **ODO** > 1000 km (621 mi)

- Press the **SET** button when the menu is closed.
- Press the **UP** or **DOWN** button until **Settings** is highlighted. Press the **SET** button to open the menu.
- Press the **UP** or **DOWN** button until **Shift Light** is highlighted. Press the **SET** button to open the submenu.
- Press the **UP** or **DOWN** button until **RPM2** is highlighted. Press the **SET** button to open the submenu.
- Activate the menu item using the **UP** or **DOWN** button.
- Set the value for **SET** by pressing the **RPM2** button.



Note

RPM2 can be set in intervals of 500 between 7,000 and 10,000 rpm.

RPM2 must not be smaller than **RPM1**.

If the engine speed reaches the set value **RPM2**, the shift warning light flashes and the color changes.

7 Combination instrument

7.19.28 Setting the time and date

Condition: Motorcycle is stationary

- Press the **SET** button when the menu is closed.
- Press the **UP** or **DOWN** button until **Settings** appears. Pressing the **SET** button opens the menu.
- Press the **UP** or **DOWN** button until **Clock & Date** is highlighted. Press the **SET** button to open the submenu.
- Select one of the following alternatives.

Setting the clock

- Press the **UP** or **DOWN** button until **Set Clock** is marked.
- Press the **SET** button to open the submenu.
- Press the **UP** or **DOWN** button until the hour is set. Press the **SET** button to select the hour.
- Press the **UP** or **DOWN** button until the minute is set. Press the **SET** button to select the minute.
- Press the **BACK** button to exit the menu.

Setting the date

- Press the **UP** or **DOWN** button until **Set Date** is marked.
- Press the **SET** button to open the submenu.
- Press the **UP** or **DOWN** button until the day is set. Press the **SET** button to select the day.
- Press the **UP** or **DOWN** button until the month is set. Press the **SET** button to select the month.
- Press the **UP** or **DOWN** button until the year is set. Press the **SET** button to select the year.
- Press the **BACK** button to exit the menu.

7.19.29 Date format

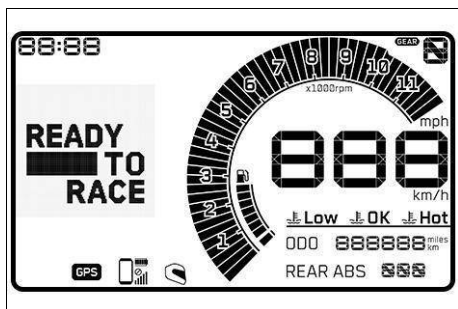

Condition: Motorcycle is stationary

- Press the **SET** button when the menu is closed.
- Press the **UP** or **DOWN** button until **Settings** is highlighted. Press the **SET** button to open the menu.
- Press the **UP** or **DOWN** button until **Clock & Date** is highlighted. Press the **SET** button to open the submenu.
- Press the **UP** or **DOWN** button until **Date Format** is highlighted. Press the **SET** button to open the submenu.
- Activate the menu item using the **UP** or **DOWN** button.
- Press the **SET** button to select the date format.

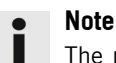

Note

The possible settings are DD.MM.YYYY, MM.DD.YYYY and YYYY.MM.DD.

7.19.30 Units

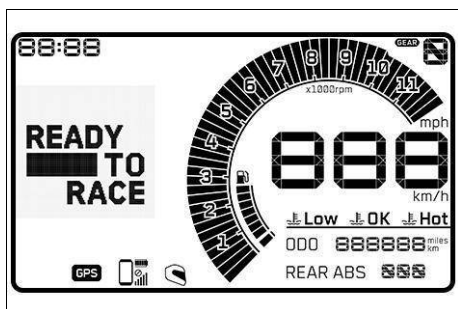

Condition: Motorcycle is stationary

- Press the **SET** button when the menu is closed.
- Press the **UP** or **DOWN** button until **Settings** is highlighted. Press **SET** button to open the menu.
- Press the **UP** or **DOWN** button until **Units** is highlighted. Press the **SET** button to open the submenu.

The **Units** submenu allows settings to be made for units or various values.

7.19.31 Distance

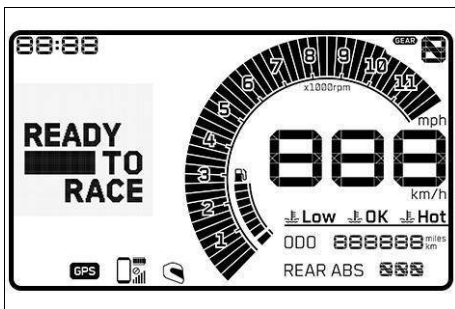

Condition: Motorcycle is stationary

- Press the **SET** button when the menu is closed.
- Press the **UP** or **DOWN** button until **Settings** is highlighted. Press **SET** button to open the menu.
- Press the **UP** or **DOWN** button until **Units** is highlighted. Press the **SET** button to open the submenu.
- Press the **UP** or **DOWN** button until **Distance** is marked. Press the **SET** button to open the submenu.
- Activate the menu item using the **UP** or **DOWN** button.
- Press the **SET** button to confirm the desired unit.



Note

Kilometers and miles can be set.

7.19.32 Temperature

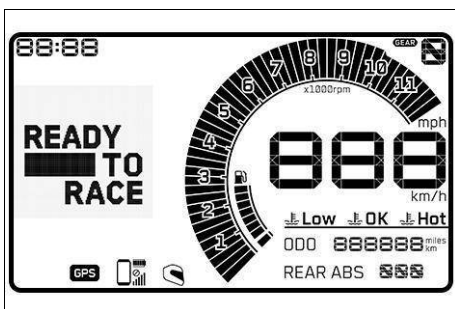

Condition: Motorcycle is stationary

- Press the **SET** button when the menu is closed.
- Press the **UP** or **DOWN** button until **Settings** is highlighted. Press **SET** button to open the menu.
- Press the **UP** or **DOWN** button until **Units** is highlighted. Press the **SET** button to open the submenu.
- Press the **UP** or **DOWN** button until **Temperature** is marked. Press the **SET** button to open the submenu.
- Activate the menu item using the **UP** or **DOWN** button.
- Press the **SET** button to confirm the desired unit.



Note

Celsius and Fahrenheit can be set.

7.19.33 Consumption

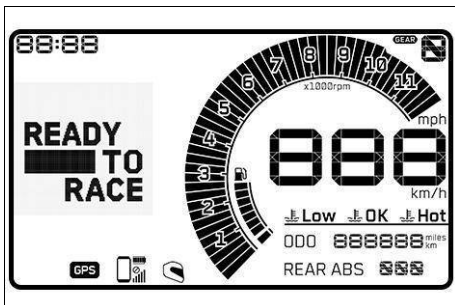

Condition: Motorcycle is stationary

- Press the **SET** button when the menu is closed.
- Press the **UP** or **DOWN** button until **Settings** is highlighted. Press **SET** button to open the menu.
- Press the **UP** or **DOWN** button until **Units** is highlighted. Press the **SET** button to open the submenu.
- Press the **UP** or **DOWN** button until **Consumption** is marked. Press the **SET** button to open the submenu.
- Activate the menu item using the **UP** or **DOWN** button.
- Press the **SET** button to confirm the desired unit.



Note

The following can be set: l/100 km, km/l, USG/100 mi, mi/USG, malfunction indicator light, UKG/100 mi and mi/UKG.

7.19.34 Extra Functions

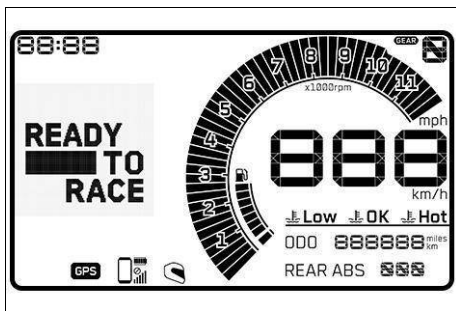

Condition: Motorcycle is stationary, Motorcycle with optional supplementary function

- Press the **SET** button when the menu is closed.
- Press the **UP** or **DOWN** button until **Settings** is highlighted.
- Press the **SET** button to open the menu.
- Press the **UP** or **DOWN** button until **Extra Functions** is highlighted. Press the **SET** button to open the submenu.
- Use the **UP** or **DOWN** button to navigate through the extra functions.

i Note

The optional extra functions are listed.
The current **KTM PowerParts** and available software are listed on the KTM website.

8.1 Notes on preparing for first use



DANGER

Danger of accidents A rider who is not fit to ride poses a danger to themselves and to others.

- Do not operate the vehicle if you are not fit to ride due to alcohol, drugs, or medication.
- Do not operate the vehicle if you are physically or mentally incapable of doing so.



WARNING

Danger of accidents Non-approved or non-recommended tyres and wheels impact the handling characteristic.

- Only use tires and wheels approved and recommended by the vehicle manufacturer with the corresponding speed rating.



WARNING

Danger of accidents New tires have reduced road grip.

The contact surface on new tires is not yet roughened.

- Run in new tires with moderate riding and only gradually increase the lean angle.

Run-in distance	200 km (124.3 mi)
-----------------	----------------------



WARNING

Danger of accidents Different tire profiles on the front and rear wheels can make it more difficult to control the vehicle.

- Make sure that only tires of the same tread type are mounted to the front and rear wheel.



WARNING

Risk of injury Missing or inadequate protective clothing increases the risk of injury.

- Wear appropriate protective clothing such as helmet, boots, gloves as well as pants and a jacket with protectors on all rides.
- Always wear protective clothing that is in good condition and meets the legal regulations.



Note

When using the vehicle, remember that others may feel disturbed by excessive noise.

- Ensure that the pre-delivery inspection has been carried out by an authorized contractual partner.
 - ✓ The delivery certificate is transferred upon vehicle handover.
- Read the entire owner's manual before riding for the first time.
- Get to know the controls.
- Get used to the handling characteristics of the motorcycle on suitable terrain before undertaking a more challenging ride. Also, ride as slowly as possible to get a better feeling for the motorcycle.
- Hold the handlebar firmly with both hands and keep your feet on the footpegs when riding.
- Run in the engine. 📖 (p. 48)



8.2 Running in the engine

- During the running-in time, do not exceed the specified engine speed.

Avoid fully opening the throttle.

Maximum engine speed

During first: 1,000 km (621.4 mi)

7,500 rpm (125.00 Hz)



Note

During the running-in phase, the shift warning light is set to a specified value and cannot be changed.

8.3 Loading the vehicle



WARNING

Fire hazard The hot exhaust system may burn luggage.

- Fasten your luggage in such a way that it cannot be burned or singed by the hot exhaust system.



WARNING

Danger of accidents A high payload alters the handling characteristic and increases the stopping distance.

- Adapt your speed to your payload.



WARNING

Danger of accidents Carrying luggage alters handling characteristics.

- Adapt your speed to your payload.
- Ride more slowly if your vehicle is loaded with cases or other luggage.

Maximum speed with luggage

130 km/h (80.8 mph)



WARNING

Danger of accidents Items of luggage that have slipped or are incorrectly fastened can obscure the lighting system.

- Check that your luggage is fixed properly at regular intervals.
- Make sure that the lighting system is not covered by luggage.



WARNING

Danger of accidents Total weight and axle loads influence the handling characteristic.

The total weight consists of: operational vehicle with a full tank, rider and, if applicable, a passenger with protective clothing and helmet, and, if applicable, mounted luggage.

- Do not exceed the maximum permissible total weight or the axle loads.



WARNING

Danger of accidents Improper mounting of cases, tank rucksacks or other luggage impairs the handling characteristics.

Luggage mounted incorrectly can slip while the vehicle is in motion.

- Mount and secure all luggage according to the manufacturer's instructions.
- Check that your luggage is fixed properly at regular intervals.



WARNING

Danger of accidents The luggage system will be damaged if it is overloaded.

- Read the manufacturer information on maximum payload when mounting cases.

- If luggage is carried, ensure it is fixed firmly as close as possible to the center of the vehicle and ensure even weight distribution between the front and rear wheels.

The maximum permissible total weight and the maximum permissible axle loads must not be exceeded.	
Maximum permissible total weight	355 kg (782.6 lb)
Maximum permissible front axle load	127 kg (280.0 lb)
Maximum permissible rear axle load	228 kg (502.7 lb)









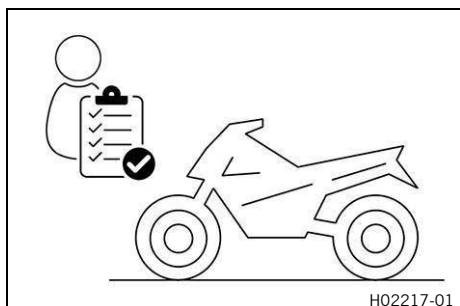



9.1 checks and maintenance measures when preparing for use

i Note

Before every trip, check the condition of the vehicle and ensure that it is roadworthy. The vehicle must be in perfect technical condition when it is being operated.



- Check the engine oil level.  (p. 102)
- Check the brake fluid level for the front brake.  (p. 72)
- Check the brake fluid level for the rear brake.  (p. 74)
- Check that the brake pads of the front brake are secured.  (p. 73)
- Check that the brake pads of the rear brake are secured.  (p. 76)
- Check that the brake system is functioning properly.
- Check the coolant level.  (p. 95)
- Check the chain for dirt.  (p. 66)
- Check the chain tension.  (p. 67)
- Check the tire condition.  (p. 81)
- Check the tire pressure.  (p. 82)
- Check the settings of all controls and ensure that they can be operated smoothly.
- Check that the electrical equipment is functioning properly.
- Check that luggage is properly secured.
- Sit on the motorcycle and check the rear mirror setting.
- Check the fuel level.

9.2 Starting



DANGER

Danger of poisoning Exhaust gases are toxic and inhaling them may result in unconsciousness and death.

- Always ensure that there is sufficient ventilation when running the engine.
- Use suitable exhaust extraction when starting or running the engine in an enclosed space.



WARNING

Danger of accidents Electronic components and safety devices will be damaged if the 12-V battery is discharged or missing.

If the 12-V battery is discharged or defective, malfunctions in the vehicle electronics can occur, especially when starting.

- Never operate the vehicle with a discharged 12-V battery or without a 12-V battery.



NOTE

Engine failure Unfiltered intake air has a negative effect on the service life of the engine.

Dust and dirt can enter the engine if there is no air filter or if the air filter is mounted incorrectly.

- Only operate the vehicle if an air filter is correctly fitted.



NOTE

Engine failure Running a cold engine at high engine speeds negatively impacts the service life of the engine.

- Always warm up the engine at low engine speeds.

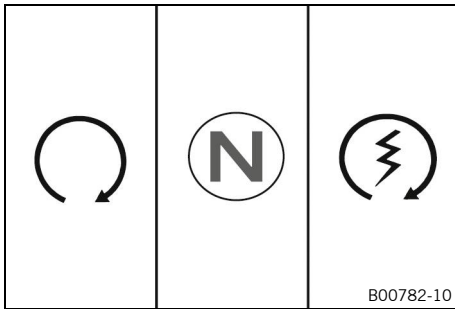

- Unlock steering. (p. 20)
- Sit on the vehicle, take the weight off of the side stand, and move it all the way up with your foot.
- Press the kill switch into position .
- Switch on the ignition by turning the ignition key to position .

To avoid malfunctions in the control unit communication, do not switch the ignition off and on in rapid succession.

- ✓ After you switch on the ignition, you can hear the fuel pump working for about two seconds. The function check of the combination instrument is run at the same time.
- Shift the transmission into the neutral position.
 - ✓ Green neutral indicator **N** lights up.
 - ✓ The **ABS** warning light lights up and goes back out after starting off.
- Briefly press start button .

Do not press the start button until the combination instrument function check has finished.

Do not open the throttle to start.

Press the starter for a maximum of 5 seconds. Wait at least 5 seconds until the next start attempt.

After 6 unsuccessful starting attempts, do not try again, and check the vehicle for other malfunctions instead.



Note

This motorcycle is equipped with a safety starting system. You can only start the engine if the transmission is in neutral or if the clutch lever is pulled when a gear is engaged. If the side stand is folded out and you shift into gear and release the clutch lever, the engine stops.



9.3 Starting off

- Pull the clutch lever, shift into first gear, release the clutch lever slowly and at the same time carefully open the throttle.



Tip

If the engine dies while starting off, only pull the clutch lever and press the start button. The transmission must not be shifted into neutral.



9.4 Quickshifter+ (optional)

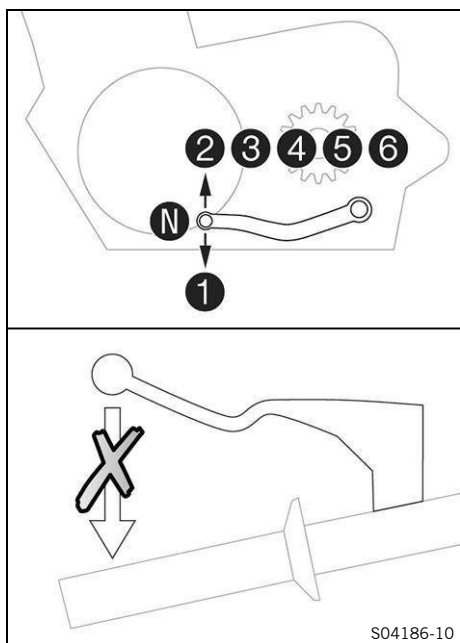

If the **QUICKSHIFTER+** is activated, you can shift up and down without actuating the clutch.

Because there is no need to close the throttle grip, uninterrupted gear shifts are possible.

The **QUICKSHIFTER+** uses the shift shaft position to check whether or not a shift should be initiated, and sends a corresponding signal to the engine control unit.

If the **QUICKSHIFTER+** is disabled in the combination instrument, the clutch needs to be actuated in the normal way for each shift.

9.5 Shifting, riding.



WARNING

Risk of injury The passenger may fall from the vehicle if they act incorrectly.

- Ensure that the passenger sits correctly on the passenger seat, places his or her feet on the passenger foot pegs and holds on to the rider or the grab handles.



WARNING

Danger of accidents Not adapting the riding style constitutes a major risk.

- Comply with traffic regulations and ride defensively and with foresight to detect sources of danger as early as possible.



WARNING

Danger of accidents Total weight and axle loads influence the handling characteristic.

The total weight consists of: operational vehicle with a full tank, rider and, if applicable, a passenger with protective clothing and helmet, and, if applicable, mounted luggage.

- Do not exceed the maximum permissible total weight or the axle loads.



WARNING

Danger of accidents Improper mounting of cases, tank rucksacks or other luggage impairs the handling characteristics.

Luggage mounted incorrectly can slip while the vehicle is in motion.

- Mount and secure all luggage according to the manufacturer's instructions.
- Check that your luggage is fixed properly at regular intervals.



WARNING

Danger of accidents Adjustments to the vehicle distract attention from traffic activity.

- Make all adjustments when the vehicle is at a standstill.



WARNING

Danger of accidents Abrupt load alterations can cause the vehicle to become out of control.

- Avoid abrupt load alterations and sudden braking actions unless a hazardous situation arises.



WARNING

Danger of accidents Cold tires have reduced road grip.

- Ride the first miles carefully on every journey at moderate speed until the tires reach operating temperature.



WARNING

Danger of accidents New tires have reduced road grip. The contact surface on new tires is not yet roughened.

- Run in new tires with moderate riding and only gradually increase the lean angle.

Run-in distance	200 km (124.3 mi)
-----------------	----------------------



WARNING

Danger of accidents A fall can damage the vehicle more seriously than it may first appear.

- Check the vehicle after a fall as you do when preparing for use.



WARNING

Danger of accidents An incorrect ignition key position causes malfunctions.

- Do not change the ignition key position while riding.



WARNING

Danger of accidents If you downshift at high engine speed, the rear wheel blocks and the engine races.

- Do not downshift to a lower gear at high engine speeds.



NOTE

Engine failure Overheating damages the engine.

- If the coolant temperature warning is displayed, stop immediately and take care not to endanger yourself or other traffic participants in the process.
- Allow the engine and cooling system to cool down.
- Check and, if necessary, correct the coolant level on the cooling system while it is in a cooled state.



NOTE

Transmission damage Incorrect use of the QUICKSHIFTER+ will damage the transmission. The QUICKSHIFTER+ can only be used if the function is enabled in the combination instrument. The QUICKSHIFTER+ is not active if you pull the clutch lever.

- Only use the QUICKSHIFTER+ in the permitted speed range shown.



Note

If you hear unusual noises while riding, stop immediately in a safe manner, switch off the engine, and contact an authorized contractual partner.

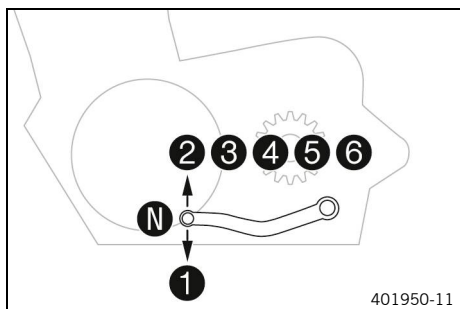

9 Riding instructions



- Shift into a higher gear when conditions allow (incline, road situation, etc.).
- Release the throttle while simultaneously pulling the clutch lever, shift into the next gear, release the clutch lever, and open the throttle.

i Note

The gear positions can be seen in the figure. The neutral or idle position is between the first and second gears. First gear is used for starting off or for steep inclines. The operating temperature is reached when 4 bars of the temperature indicator light up.

- Only open the throttle as much as the engine can handle. Abruptly opening the throttle increases fuel consumption. Accelerate only up to a speed suitable for the road surface and weather conditions. In particular, you should not change gear on bends and should only accelerate very cautiously.
- Brake if necessary and close the throttle at the same time in order to shift down.
- Pull clutch lever and shift into a lower gear, release the clutch lever slowly, and open the throttle or shift again.
- Switch off the engine if you are likely to be running at idle speed or stationary for a long time.
- If the oil pressure warning lamp  lights up during a trip, stop as soon as it is safe to do so and switch off the engine. Contact an authorized contractual partner.
- If the malfunction indicator light  lights up during a trip, please contact an authorized contractual partner as soon as possible.
- If the general warning lamp  lights up during a trip, an operating safety (warning) message was detected.

i Note

All warnings which have occurred are displayed and stored in the **Warning** menu until these are no longer active.

- If the **QUICKSHIFTER+** (optional) is activated in the combination instrument, you can shift up in the engine speed range indicated without pulling the clutch lever.

i Note

The minimum engine speed before shifting up in revolutions per minute is shown in the figure. Pull the shift lever to the stop quickly without changing the throttle twist grip position.

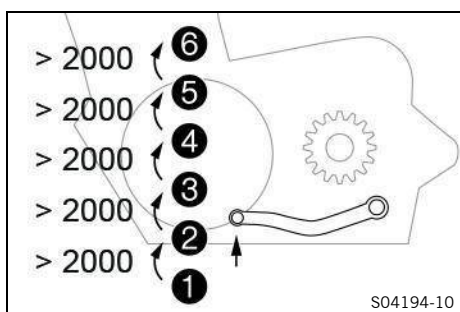

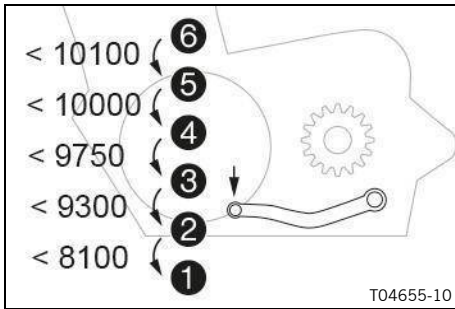

- If the QUICKSHIFTER+ is activated in the combination instrument, you can shift down in the engine speed range shown without pulling the clutch lever.

i Note
The maximum engine speed before shifting down in revolutions per minute is shown in the figure.
Press the shift lever to the stop quickly without changing the throttle twist grip position.

9.6 Braking.

! WARNING
Danger of accidents A spongy pressure point on the front or rear brake reduces the brake action.
- Do not drive the vehicle if the brake system has a spongy pressure point.

! WARNING
Danger of accidents The brake system fails in the event of overheating.
If the brake pedal is not released, the brake pads grind continuously.
- Take your foot off the brake pedal when you are not braking.

! WARNING
Danger of accidents Moisture and dirt impair the brake system.
- Brake carefully several times to dry out and remove dirt from the brake pads and the brake discs.

! WARNING
Danger of accidents Salt on the roads impairs the brake system.
- Brake carefully several times to remove salt from the brake linings and the brake discs.

! WARNING
Danger of accidents Higher total weight increases the stopping distance.
- Take the longer stopping distance into account when carrying a passenger or luggage with you.

! WARNING
Danger of accidents Braking with excessive force locks the wheels.
The ABS effectiveness is only ensured if it is switched on.
- Leave the ABS switched on in order to benefit from the protective effect.

! WARNING
Danger of accidents ABS may increase the stopping distance in certain situations.
- Adapt your braking to the riding situation and the road conditions.

- When braking, release the throttle and apply the front and rear brakes at the same time.

i Note
When the **ABS** is enabled, maximum braking power can be applied even on surfaces with low road grip such as sandy, wet, or slippery terrain without the danger of the wheels locking.



WARNING

- Danger of accidents** The rear wheel can lock due to the engine braking effect.
- Pull the clutch when performing emergency braking or braking on slippery surfaces.



WARNING

- Danger of accidents** Banked or laterally sloping ground reduces the maximum possible delay.
- If possible finish braking before going into a bend.

- Always finish braking before you go into a bend. Shift into a lower gear that suits the speed.
- Use the brake action of the engine on long downhill stretches. Shift down one or two gears, but do not overrev the engine when doing so. This means that significantly less braking is required and means the brake system does not overheat.

9.7 Stop, park



WARNING

- Risk of injury** People who act without authorization endanger themselves and others.
- Never leave the vehicle unattended while the engine is running.
 - Lock the steering and remove the ignition key if you leave the vehicle unattended.



WARNING

- Danger of burns** Some vehicle components become hot when the vehicle is operated.
- Do not touch any parts such as the exhaust system, radiator, engine, damper, or brake system before the vehicle parts have cooled down.
 - Allow the vehicle parts to cool down before performing any work on the vehicle.



NOTE

- Fire hazard** Hot vehicle components pose a fire hazard and explosion risk.
- Do not park the vehicle near materials which are highly flammable or explosive.
 - Allow the vehicle to cool down before covering it.



NOTE

- Material damage** The vehicle may be damaged if parked incorrectly. Damage can occur if the vehicle rolls away or falls over. The components for parking the vehicle are designed only for the weight of the vehicle.
- Park the vehicle on a firm and level surface.
 - Make sure that nobody sits on the vehicle when it is parked on a stand.

- Brake the motorcycle.
- Shift the transmission into the neutral position.
- Switch off the ignition by turning the ignition key to position



Note

If the engine is switched off with the emergency OFF switch and the ignition remains switched on in the ignition lock, the power supply to most electrical power consumers remains uninterrupted and this discharges the 12-V battery. You should therefore always switch off the engine with the ignition lock – the kill switch is intended for emergencies only.

- Park the motorcycle on a firm surface.
- Swing side stand forward with your foot as far as it will go and lean the vehicle on it.
- Lock the steering. (p. 20)

9.8 Transport



NOTE

Fire hazard Hot vehicle components pose a fire hazard and explosion risk.

- Do not park the vehicle near materials which are highly flammable or explosive.
- Allow the vehicle to cool down before covering it.



NOTE

Material damage The vehicle may be damaged if parked incorrectly.

Damage can occur if the vehicle rolls away or falls over.

The components for parking the vehicle are designed only for the weight of the vehicle.

- Park the vehicle on a firm and level surface.
- Make sure that nobody sits on the vehicle when it is parked on a stand.

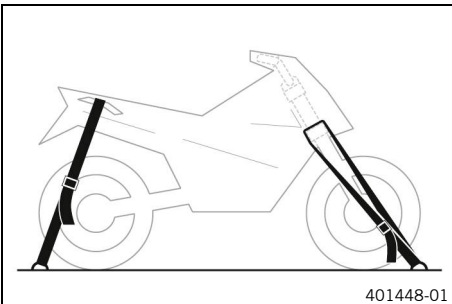

- Switch off the engine and remove the ignition key.
- Use tension belts or other suitable devices to secure the motorcycle against falling over or rolling away.

9.9 Towing in the event of a breakdown



NOTE

Danger of damage Damage to the powertrain and transmission can occur when towing with a towing vehicle.

- Do not use towing equipment where the wheels of the broken down vehicle remain on the road and rotate as it is towed.
- Always transport a broken down vehicle on a trailer or on the loading area of a transport vehicle.

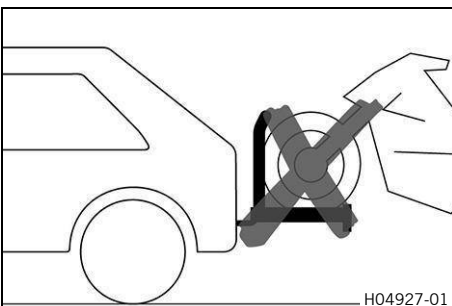

- Ensure that the broken down vehicle is properly secured on the trailer or transport vehicle.
- Observe local regulations for the recovery of broken down vehicles.

9.10 Refueling



DANGER

Fire hazard Fuel is highly flammable.

The fuel in the fuel tank expands when warm and can escape if overfilled.

- Do not refuel the vehicle in the vicinity of open flames, glowing, or smoldering objects.
- Make sure that nobody smokes in the vicinity of the vehicle during the refueling process.
- Switch off the engine for refueling.
- Make sure that no fuel is spilled; particularly not on hot parts of the vehicle.
- If any fuel is spilled, wipe it up immediately.
- Do not overfill the fuel tank.



WARNING

Danger of poisoning Fuel is harmful to health.

- Do not allow fuel to come into contact with skin, eyes, or clothing.
- Consult a doctor immediately if fuel has been ingested.
- Do not inhale fuel vapors.
- Rinse the affected area immediately with plenty of water in the event of contact with skin.
- Rinse eyes thoroughly with water and consult a doctor immediately if fuel comes into contact with eyes.
- If fuel spills on to your clothing, change the clothing.
- Store fuel properly in a suitable container and keep out of the reach of children.



NOTE

Material damage Inadequate fuel quality can lead to losses in performance and consequential damage.

- Refuel only with clean fuel that meets the specified standards.



NOTE

Environmental hazard Improper handling of fuel is dangerous to the environment.

- Do not allow fuel to enter the groundwater, the soil, or the sewage system.

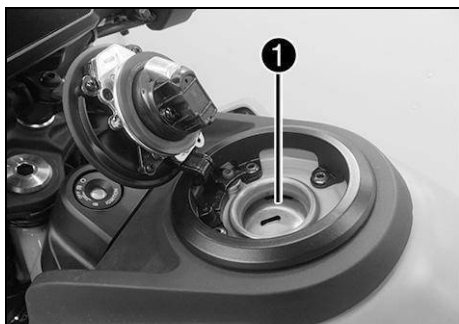

- Switch off the engine.
- Open the fuel tank cap. (p. 20)
- Fill the fuel tank with fuel up to the lower edge **1** of the filler neck.

Total fuel tank capacity, approx.	
Super unleaded (ROZ 95) (p. 128)	15 l (4.0 liq. gal _{US})



























- Close the fuel tank cap. (p. 21)

















T04646-01

10.1 Service work

Any further work that results from the service work must be ordered separately and invoiced separately. Different service intervals may apply in your country, depending on the local operating conditions. Individual service intervals and scopes may change in the course of technical developments. The most up-to-date service schedule is available for authorized contractual partners for the electronic proof of service. Your authorized contractual partner will be happy to advise you.

	Every 48 months					
	Every 24 months			Every 12 months		
	every 15,000 km (9,320.6 mi)					
	every 7,500 km (4,660.3 mi)					
	after 1,000 km (621.4 mi)					
Read out the fault memory using the diagnostics tool. 	○	●	●	●	●	●
Program the shift shaft sensor. 	○	●	●			
Check that the electrical equipment is functioning properly. 	○	●	●	●	●	●
Check that the brake pads of the front brake are secured.  (p. 73)	○	●	●	●	●	●
Check that the brake pads of the rear brake are secured.  (p. 76)	○	●	●	●	●	●
Check the brake discs.  (p. 71)	○	●	●	●	●	●
Check the brake lines for damage and tightness. 	○	●	●	●	●	●
Check the brake fluid level for the front brake.  (p. 72)	○	●	●	●		
Change the brake fluid for the front brake. 					●	●
Check the brake fluid level for the rear brake.  (p. 74)	○	●	●	●		
Change the brake fluid for the rear brake. 					●	●
Change the engine oil and the oil filter, clean the oil screens.   (p. 102)	○	●	●	●	●	●
Check all hoses (e.g. fuel, cooling, bleeder, drainage, etc.) and boots for cracking, leaks, and correct routing. 	○	●	●	●	●	●
Empty the drainage hoses. 	○	●	●	●	●	●
Check the cables for damage and that there are no kinks in the routing. 	○	●	●	●	●	●
Check the frame. 				●		
Check the swingarm. 				●		
Check the swingarm bearing for play. 		●	●			
Check the steering head bearing play. 	○	●	●			
Check the wheel bearing for play. 		●	●			
Check the shock absorber and fork for leaks.	○	●	●	●	●	●
Check the tire condition.  (p. 81)	○	●	●	●	●	●
Check the tire pressure.  (p. 82)	○	●	●	●	●	●
Check the chain, rear sprocket, and engine sprocket.  (p. 68)		●	●	●	●	●
Check the chain tension.  (p. 67)	○	●	●	●	●	●
Grease all moving parts (e.g. side stand, hand lever, chain, etc.) and check for smooth operation. 	○	●	●	●	●	●
Check that the clutch cables are undamaged, routed without kinks, and set correctly. 	○	●	●	●	●	●

10 Service schedule

	Every 48 months					
	Every 24 months			Every 12 months		
	every 15,000 km (9,320.6 mi)					
	every 7,500 km (4,660.3 mi)					
	after 1,000 km (621.4 mi)					
Check the valve clearance, change the spark plug. 				•		
Change the air filter, clean the air filter box. 		•	•			
Check the headlight adjustment.  (p. 91)	○	•	•			
Check the tightness of the safety-relevant screws and nuts which are easily accessible. 	○	•	•	•	•	•
Clean the dust boots of the fork legs.  (p. 64)		•	•			
Check that the radiator fan is functioning properly. 	○	•	•	•	•	•
Check the coolant level.  (p. 95)	○	•	•	•	•	
Checking the antifreeze. 		•	•		•	
Change the coolant.   (p. 98)						•
Final check: Check the vehicle is roadworthy and take a test ride. 	○	•	•	•	•	•
Read out the fault memory after the test ride using the diagnostics tool. 	○	•	•	•	•	•
Reset the service interval display. 	○	•	•	•	•	•
Enter electronic proof of service. 	○	•	•	•	•	•

- One-time interval
- Periodic interval

11.1 Adjusting the spring preload of the shock absorber



WARNING

Danger of accidents Modifications to the suspension settings that are not properly coordinated can impair the handling and overload components.

- Only make adjustments within the recommended range.
- Ride slowly to start with after making adjustments to get the feel of the new handling characteristics.



Note

The spring preload defines the initial status of the spring operation on the shock absorber.

The best spring preload setting is achieved when it is set for the weight of the rider and that of any luggage and a passenger, thus ensuring an ideal compromise between handling and stability.

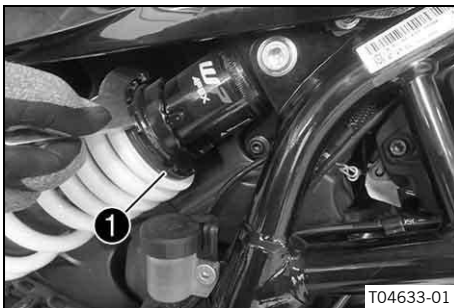

- Adjust the spring preload by turning adjusting ring **1**.

Preload	
Standard	3 clicks

Hook wrench (90529077000)	
Extension for hook wrench (90129099025)	



Note

The spring preload can be set to 10 different positions.

11.2 Adjusting the shift lever



Note

The adjustment range of the shift lever is limited.

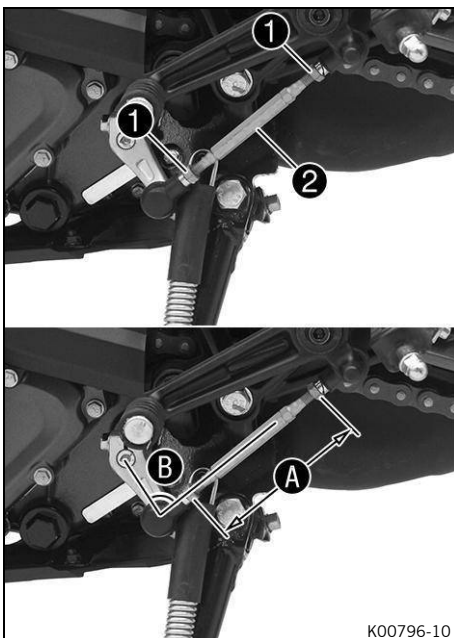

- Loosen nuts **1**.
- Adjust the shift lever by turning shift rod **2**.

Make the same adjustments on both sides.	
At least five screw threads must be screwed into the seating.	
Shift rod adjustment range A	110 mm ... 122 mm (4.33 in ... 4.80 in)

- Check adjusting angle **B**.

Adjusting angle B shift rod - bell crank - shift lever	90° (1.57 rad)
---	-------------------

- Tighten nuts **1**.

After the nuts have been tightened, the bearings of the shift rod must be central and aligned identically to each other in order to ensure freedom of movement in the bearing shells.

- Check the shift lever to ensure it is functioning properly and can move freely.

12.1 Raising the motorcycle with rear lifting gear



NOTE

Material damage The vehicle may be damaged if parked incorrectly.

Damage can occur if the vehicle rolls away or falls over.

The components for parking the vehicle are designed only for the weight of the vehicle.

- Park the vehicle on a firm and level surface.
- Make sure that nobody sits on the vehicle when it is parked on a stand.

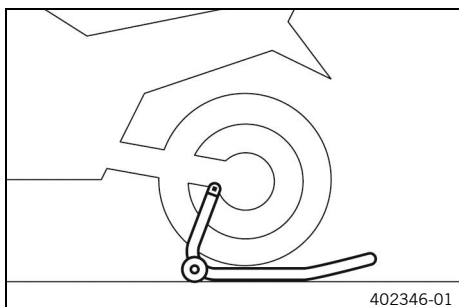

- Mount the supports of the wheel stand.
- Insert the adapter in the rear wheel stand.

Retaining adapter (61029955244)

Rear wheel work stand (69329955000)

- Stand the motorcycle upright, align the wheel stand with the swingarm and the adapters, and raise the motorcycle.

12.2 Removing the rear of the motorcycle from the lifting gear



NOTE

Material damage The vehicle may be damaged if parked incorrectly.

Damage can occur if the vehicle rolls away or falls over.

The components for parking the vehicle are designed only for the weight of the vehicle.

- Park the vehicle on a firm and level surface.
- Make sure that nobody sits on the vehicle when it is parked on a stand.

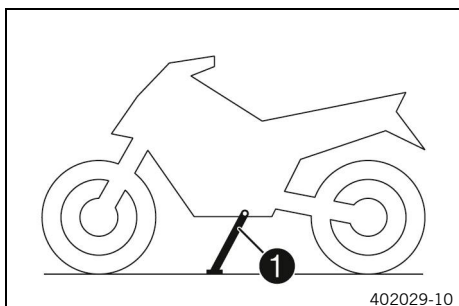

- Secure the motorcycle against falling over.
- Remove the rear lifting gear and lean the vehicle on side stand ①.
- Remove bushings kit.

12.3 Lifting the motorcycle with the front lifting gear



NOTE

Material damage The vehicle may be damaged if parked incorrectly.

Damage can occur if the vehicle rolls away or falls over.

The components for parking the vehicle are designed only for the weight of the vehicle.

- Park the vehicle on a firm and level surface.
- Make sure that nobody sits on the vehicle when it is parked on a stand.

Preparatory work

- Raise the motorcycle with the rear lifting gear.  (p. 62)

Main work

- Remove protection cap ❶.

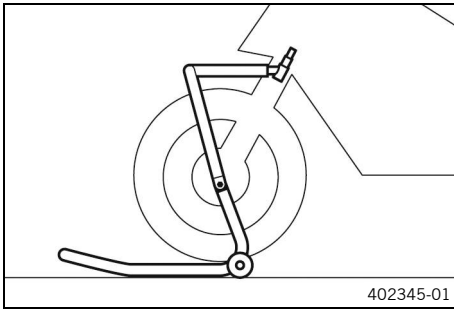
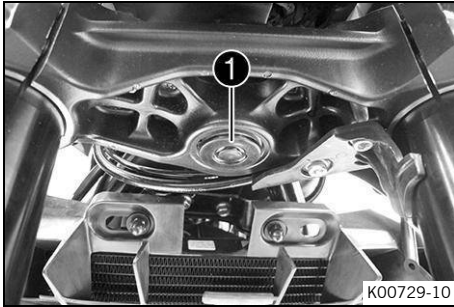

- Move the handlebar to the straight-ahead position.
- Position the lifting gear.

Always raise the motorcycle at the rear first.
--

Mounting pin (69329965030)

Front wheel work stand, large (69329965100)

- Lift the motorcycle at the front.

12.4 Taking the motorcycle off the front lifting gear



NOTE

Material damage The vehicle may be damaged if parked incorrectly.

Damage can occur if the vehicle rolls away or falls over.

The components for parking the vehicle are designed only for the weight of the vehicle.

- Park the vehicle on a firm and level surface.
- Make sure that nobody sits on the vehicle when it is parked on a stand.

Main work

- Secure the motorcycle against falling over.
- Remove the front lifting gear.

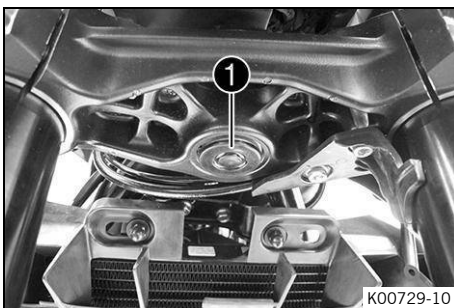
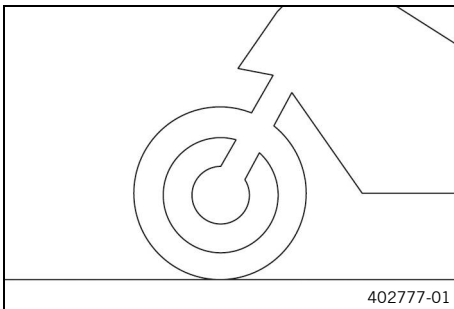



- Mount protection cap ❶.

Reworking

- Remove the rear of the motorcycle from the lifting gear.  (p. 62)

12.5 Cleaning the dust boots of the fork legs

Preparatory work

- Raise the motorcycle with the rear lifting gear.  (p. 62)
- Lift the motorcycle with the front lifting gear.  (p. 62)

Main work

- Push dust boots **1** of both fork legs downward.

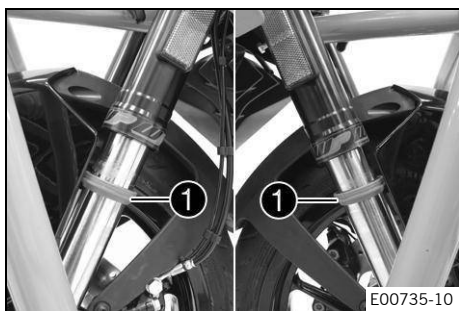

Note

The dust boots should remove dust and coarse dirt particles from the inner fork tubes. Over time, dirt can accumulate behind the dust boots. If this dirt is not removed, the oil seals behind can start to leak.



WARNING

Danger of accidents Oil, grease or wax on the brake discs reduces the brake action.



- Always keep the brake discs free of oil, fat and wax.
- Clean the brake discs with brake cleaner when necessary.

- Clean and oil the dust boots and the inner fork tube of both fork legs.

Universal oil spray  (p. 129)

- Press the dust boots back into their installation position.
- Remove excess oil.

Reworking

- Take the motorcycle off the front lifting gear.  (p. 63)
- Remove the rear of the motorcycle from the lifting gear.  (p. 62)

12.6 Removing the passenger seat

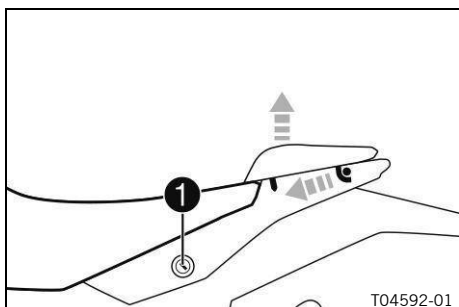

- Insert the ignition key in seat lock **1** and turn it clockwise.
- Raise the front of the passenger seat, push it toward the fuel tank, and remove it upward.
- Remove the ignition key from the seat lock.

12.7 Mounting the passenger seat

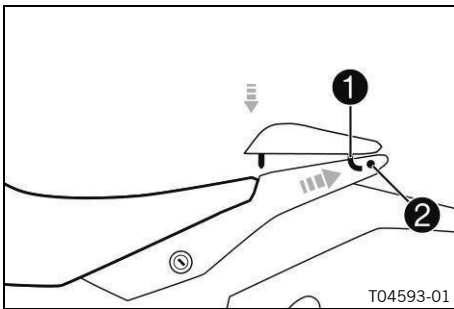

- Attach hooks ① on the passenger seat to hangers ② on the subframe and push it to the rear.
- Press the passenger seat downward until it clicks into place.



WARNING

Danger of accidents The seat can come loose from the anchoring if it is not mounted correctly.

- After assembly, check whether the seat is correctly locked and cannot be pulled up.

- Check that the passenger seat is mounted correctly.



12.8 Remove the front rider's seat

Preparatory work

- Remove the passenger seat. 📖 (p. 64)

Main work

- Raise the rear of the front rider's seat, pull it towards the rear, and remove it upwards.

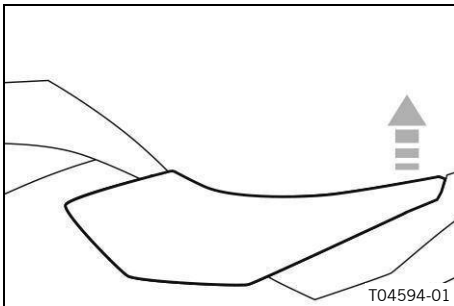

12.9 Mounting the front rider's seat

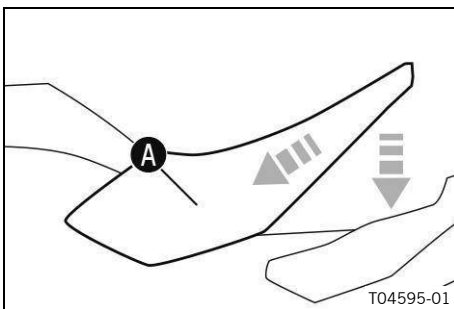

Main work

- Attach the front rider's seat in area A and lower at the rear.
- Check that the front rider's seat is mounted correctly.

Reworking

- Mount the passenger seat. 📖 (p. 65)



12.10 Checking the chain for dirt

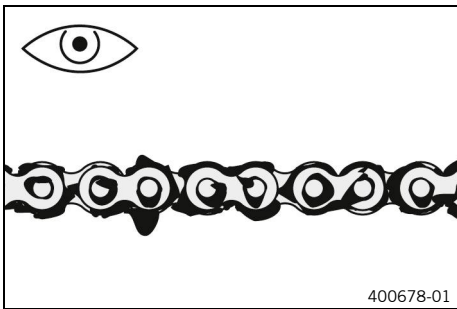

- Check the chain for coarse dirt accumulation.
 - » If the chain is very dirty:
 - Clean the chain. 📖 (p. 66)

12.11 Cleaning the chain



WARNING

Danger of accidents Oil, grease or wax on the brake discs reduces the brake action.

- Always keep the brake discs free of oil, fat and wax.
- Clean the brake discs with brake cleaner when necessary.



WARNING

Danger of accidents Lubricants on the tires reduces the road grip.

- Remove lubricants from the tires using a suitable cleaning agent.



NOTE

Environmental hazard Hazardous substances cause environmental damage.

- Dispose of oils, grease, filters, fuel, cleaning agents, brake fluid, etc. correctly and in accordance with the applicable regulations.



Note

The service life of the chain depends largely on its maintenance.

Preparatory work

- Raise the motorcycle with the rear lifting gear. 📖 (p. 62)

Main work

- Clean the chain regularly.
- Rinse off the loose dirt with a gentle jet of water.
- Remove grease residue with chain cleaner.

Chain cleaner 📖 (p. 134)

- After drying, apply chain spray.

Street chain spray 📖 (p. 129)

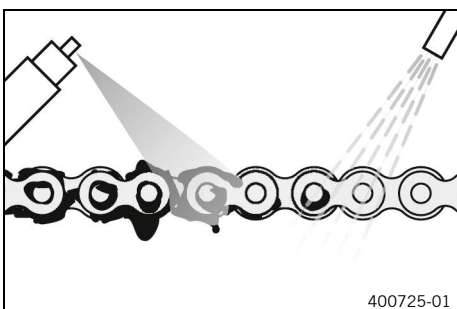

Reworking

- Remove the rear of the motorcycle from the lifting gear. 📖 (p. 62)

12.12 Checking the chain tension



WARNING

Danger of accidents Incorrect chain tension can damage components and result in an accident.

If the chain tension is too high, the chain, front sprocket, rear sprocket, transmission, and rear wheel bearings wear more quickly. Some components may break if overloaded.

If the chain is too loose, the chain may fall off the front sprocket or the rear sprocket. This can damage the rear wheel or the engine.

- Check the chain tension regularly.
- Set the chain tension in accordance with the specification.

Preparatory work

- Raise the motorcycle with the rear lifting gear. (p. 62)

Main work

- Shift the transmission into the neutral position.
- In the area after the chain sliding guard, press the chain upward toward the link fork and measure chain tension.

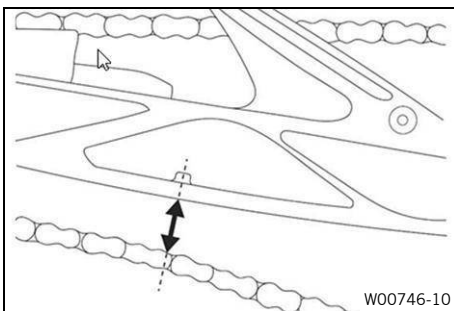

Chain tension	7 mm ... 10 mm (0.28 in ... 0.39 in)
The upper part of the chain must be taut.	
Chain wear is not always even, so repeat this measurement at different positions on the chain.	

- » If the chain tension does not meet the specification:
 - Adjust the chain tension. (p. 67)
- Remove the rear of the motorcycle from the lifting gear. (p. 62)

12.13 Adjusting the chain tension



WARNING

Danger of accidents Incorrect chain tension can damage components and result in an accident.

If the chain tension is too high, the chain, front sprocket, rear sprocket, transmission, and rear wheel bearings wear more quickly. Some components may break if overloaded.

If the chain is too loose, the chain may fall off the front sprocket or the rear sprocket. This can damage the rear wheel or the engine.

- Check the chain tension regularly.
- Set the chain tension in accordance with the specification.

Preparatory work

- Raise the motorcycle with the rear lifting gear. (p. 62)
- Check the chain tension. (p. 67)

12 Service work on the chassis

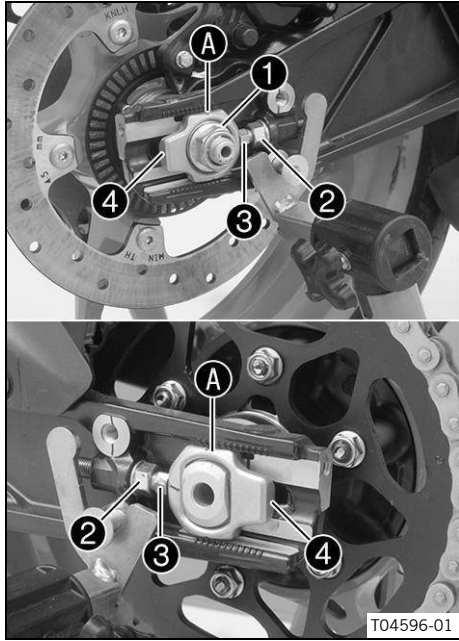

Main work

- Loosen nut ①.
- Loosen nuts ②.
- Adjust the chain tension by turning adjusting screws ③ left and right.

Chain tension	7 mm ... 10 mm (0.28 in ... 0.39 in)
In order for the rear wheel to be correctly aligned, the markings on the left and right chain adjusters must be in the same position relative to reference markings A.	
The upper part of the chain must be taut.	
Chains do not always wear evenly, so you should check the setting at different chain positions.	

- Tighten nuts ②.
- Make sure that chain adjusters ④ are fitted correctly on adjusting screws ③.
- Tighten nut ①.

Nut, wheel spindle, rear	
M16	100 Nm (73.8 ft·lb _f)

Reworking

- Remove the rear of the motorcycle from the lifting gear. (p. 62)

12.14 Checking the chain, rear sprocket, and engine sprocket

Preparatory work

- Raise the motorcycle with the rear lifting gear. (p. 62)

Main work

- Check the rear sprocket and the front sprocket for wear.
 - » If the rear sprocket and engine sprocket are worn:
 - Change the drivetrain kit.

Always replace the front sprocket, rear sprocket, and chain together.

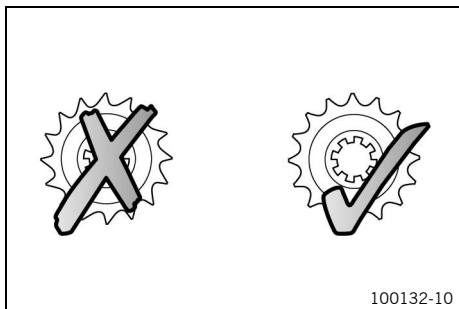

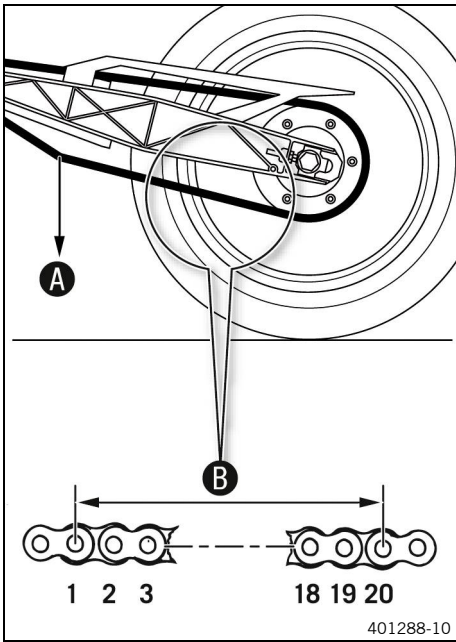

- Shift the transmission into the neutral position.
- Pull on the lower chain section with specified weight **A**.

Weight, chain wear measurement	15 kg (33.1 lb)
--------------------------------	--------------------

- Measure distance **B** of 20 chain rollers in the lower chain section.

Maximum distance B from 20 chain rollers at the longest chain section	301.6 mm (11.874 in)
--	-------------------------

Chain wear is not always even, so repeat this measurement at different positions on the chain.

- » If distance **B** is greater than the specified measurement:
 - Change the drivetrain kit.

When installing a new chain, also replace the rear sprocket and front sprocket.

i Note

New chains wear out faster on old, worn sprockets.

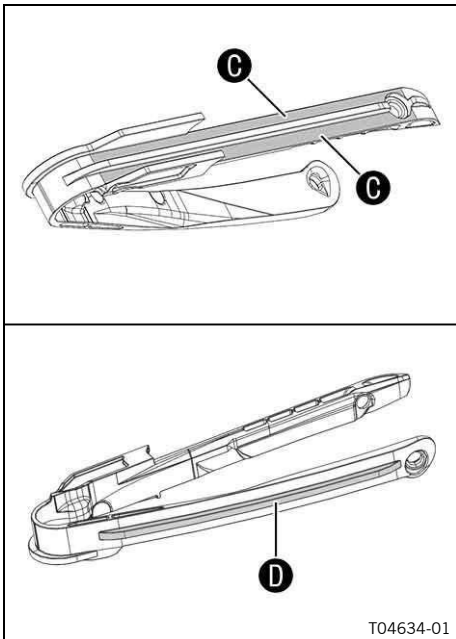

- Check the chain slider at the top for wear.
 - » If continuous signs of wear to the chain are visible on the chain slider in the areas **C** marked:
 - Change the chain slider.
 - » If the chain sliding guard is highly worn on the underside in the marked area **D**:
 - Change the chain slider.
- Check that the chain slider is firmly seated.
 - » If the chain slider is loose:
 - Tighten the screw of the chain sliding guard.

Screw, chain guard	
M5	7 Nm (5.2 ft·lb _f) Loctite® 243

Reworking

- Remove the rear of the motorcycle from the lifting gear. (p. 62)

13.1 Anti-lock braking system



WARNING

Danger of accidents Changes to the vehicle impair the function of the ABS.

- Do not make any changes to the suspension travel.
- Only use spare parts on the brake system which have been approved and recommended by the vehicle manufacturer.
- Only use tires and wheels approved and recommended by the vehicle manufacturer with the corresponding speed rating.
- Maintain the specified tire pressure.
- Ensure that service work and repairs are performed professionally.



WARNING

Danger of accidents Driving aids can reduce the probability of a fall only within physical limits.

It is not always possible to compensate for certain riding situations, for example with luggage loaded with a high center of gravity, varying road surfaces, steep descents or full braking without disengaging the gear.

- Adapt your riding style to the road conditions and your driving ability.

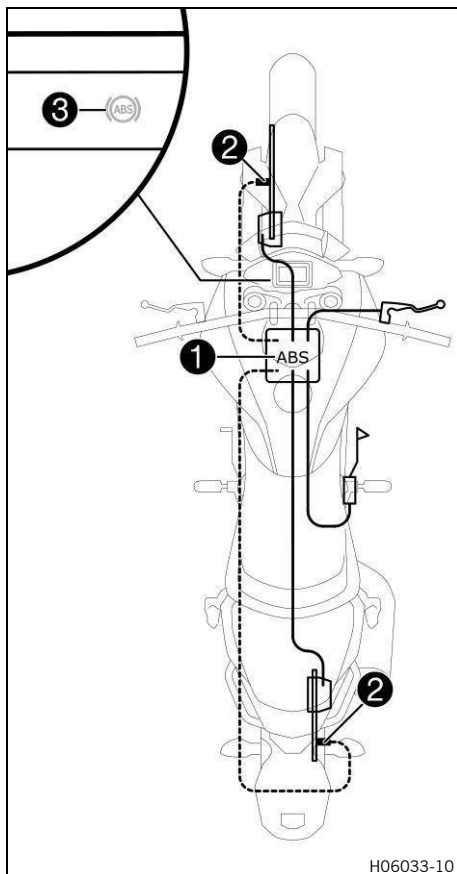

The ABS module **1**, which consists of a hydraulic unit, ABS control unit, and return pump, is installed under the fuel tank. One wheel speed sensor **2** is located in each case on the front and the rear wheel.



WARNING

Danger of accidents An incorrectly selected ABS mode makes it more difficult to control the vehicle.

The ABS modes are each only suitable for certain conditions.

- Always select an ABS mode that suits the ground and the riding situation.

ABS is a safety system that prevents locking of the wheels when riding straight ahead without the influence of lateral forces, as far as the laws of physics allow.

ABS has two operating modes: the **Road** and **Supermoto** ABS modes.

In ABS mode **Road**, the ABS controls both wheels.

In ABS mode **Supermoto**, the ABS only controls the front wheel.

Note

In the **Supermoto** ABS mode, the rear wheel may lock and there is a risk of falling.

The ABS operates with two independent brake circuits (front and rear brakes). During normal operation, the brake system operates like a conventional brake system without ABS. When the ABS control unit detects a locking tendency in a wheel, ABS begins regulating the brake pressure. The control function causes a slight pulsing of the hand and foot brake levers.

The ABS warning light **3** must light up after the ignition is switched on and go out after starting off. If it does not go out after starting off or if it lights up while riding, this indicates a malfunction in the ABS. In this case, the ABS is no longer enabled and the wheels may lock during braking. The brake system itself stays functional; only ABS control is not available.

The ABS warning light may also light up if the rotating speeds of the front and rear wheels differ greatly under extreme riding conditions, for example when doing a wheelie or if the rear wheel spins. This causes the ABS to switch off.

To reactivate the ABS, stop the vehicle and switch off the ignition. The ABS is reactivated when the vehicle is switched on again. The ABS warning light goes out after starting off.

13.2 Checking the brake discs



WARNING

Danger of accidents Worn-out brake discs reduce the braking action.

- Make sure that worn-out brake discs are replaced immediately.

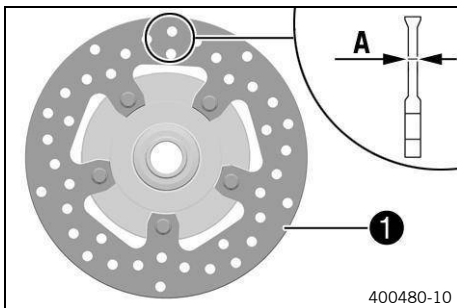

- Check front and rear brake disc thickness at multiple points for the dimension **A**.

Brake disc wear limit	
front	4.5 mm (0.177 in)
rear	4.5 mm (0.177 in)



Note

Wear will reduce the thickness of the brake disc at contact surface **1** of the brake linings.

- » If the brake disc thickness is less than the specified value.
 - Change the brake discs of the front brake. 🛠️
 - Change the brake discs on the rear brake. 🛠️
- Check the front and rear brake discs for damage, cracks, and deformation.
 - » If the brake disc shows signs of damage, cracks, or deformation:
 - Change the brake discs of the front brake. 🛠️
 - Change the brake discs on the rear brake. 🛠️

13.3 Checking the brake fluid level for the front brake



WARNING

Danger of accidents Brake fluid which is too old or of the wrong type impairs the function of the brake system.

- Make sure that brake fluid for the front and rear brake is changed in accordance with the service schedule.
- Make sure that only clean, approved brake fluid from a tightly sealed container is used.





WARNING

Danger of accidents An insufficient brake fluid level will cause the brake system to fail.

If the brake fluid level drops below the specified marking or the specified value, the brake system has a leak or the brake pads are worn down.

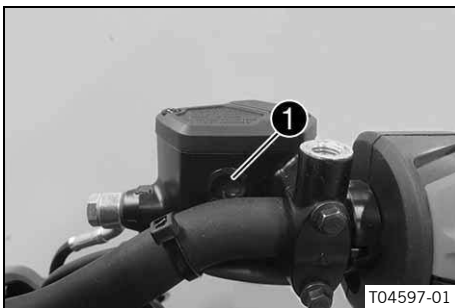
- Have the brake system checked and make sure that the problem has been eliminated before the vehicle is used again.



- Move the brake reservoir mounted on the handlebar to a horizontal position.
- Check the brake fluid level in level viewer ①.
 - » If the brake fluid level is below the **MIN** marking:
 - Add brake fluid for the front brake.   (p. 72)

13.4 Adding brake fluid for the front brake



WARNING

Danger of accidents Brake fluid which is too old or of the wrong type impairs the function of the brake system.

- Make sure that brake fluid for the front and rear brake is changed in accordance with the service schedule.
- Make sure that only clean, approved brake fluid from a tightly sealed container is used.



WARNING

Danger of accidents An insufficient brake fluid level will cause the brake system to fail.

If the brake fluid level drops below the specified marking or the specified value, the brake system has a leak or the brake pads are worn down.

- Have the brake system checked and make sure that the problem has been eliminated before the vehicle is used again.



WARNING

Health hazard Brake fluid is a harmful substance.

- Keep brake fluid out of the reach of children.
- Wear suitable protective clothing and safety glasses.
- Do not allow brake fluid to come into contact with the skin, the eyes, or clothing.
- Consult a doctor immediately if brake fluid has been ingested.
- Rinse the affected area with plenty of water in the event of contact with the skin.
- Rinse eyes thoroughly with water immediately and consult a doctor if brake fluid comes into contact with the eyes.
- If brake fluid spills on to your clothing, change the clothing.



NOTE

Environmental hazard Hazardous substances cause environmental damage.

- Dispose of oils, grease, filters, fuel, cleaning agents, brake fluid, etc. correctly and in accordance with the applicable regulations.



Note

Avoid contact between brake fluid and painted parts. Brake fluid corrodes paint.

Preparatory work

- Check that the brake pads of the front brake are secured.  (p. 73)

Main work

- Move the brake reservoir mounted on the handlebar to a horizontal position.
- Remove screws ①.
- Take off cover ② with membrane ③.
- Add brake fluid to level A.

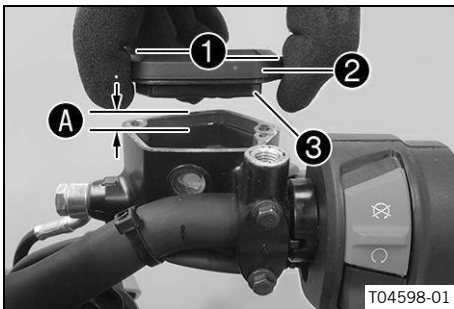

Dimension A	5 mm (0.20 in)
-------------	-------------------

Brake fluid DOT 5.1  (p. 129)

- Position the cover with diaphragm. Mount and tighten the screws.

Immediately clean up any brake fluid that has overflowed or spilled with water.

13.5 Checking that the brake pads of the front brake are secured



WARNING

Danger of accidents Worn brake pads reduce the brake action.

- Make sure that worn brake pads are replaced immediately.



WARNING

Danger of accidents Damaged brake discs reduce the braking action.

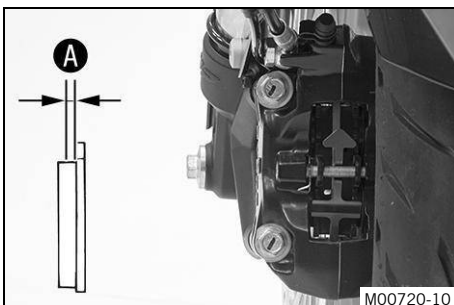

If the brake linings are not changed in time, the brake lining carriers grind against the brake disc. As a consequence, the brake action is greatly reduced and the brake discs are destroyed.

- Check the brake linings regularly.



- Check the brake linings for lining thickness A.

Minimum thickness A	≥ 1 mm (≥ 0.04 in)
---------------------	-----------------------

- » If it is less than the minimum thickness:
 - Change the front brake pads. 
- Check the brake pads for damage and cracking.
 - » If there is damage or cracking:
 - Change the front brake pads. 

- Check that the brake pads are secured.
 - » If the brake pads are not secured correctly:
 - Secure brake pads, replace with new parts if necessary.

13.6 Checking the brake fluid level for the rear brake



WARNING

Danger of accidents Brake fluid which is too old or of the wrong type impairs the function of the brake system.

- Make sure that brake fluid for the front and rear brake is changed in accordance with the service schedule.
- Make sure that only clean, approved brake fluid from a tightly sealed container is used.





WARNING

Danger of accidents An insufficient brake fluid level will cause the brake system to fail.

If the brake fluid level drops below the specified marking or the specified value, the brake system has a leak or the brake pads are worn down.

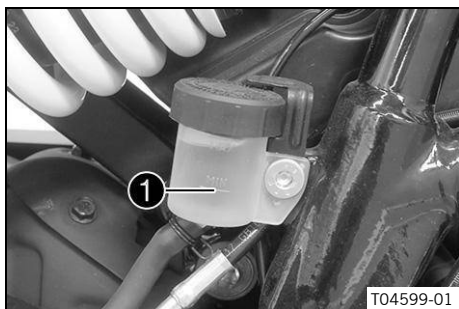
- Have the brake system checked and make sure that the problem has been eliminated before the vehicle is used again.



- Stand the vehicle upright.
- Check the brake fluid level in the brake fluid reservoir.
 - » If the fluid level reaches the **MIN** marking **1**:
 - Add brake fluid for the rear brake.   (p. 74)

13.7 Adding brake fluid for the rear brake



WARNING

Danger of accidents Brake fluid which is too old or of the wrong type impairs the function of the brake system.

- Make sure that brake fluid for the front and rear brake is changed in accordance with the service schedule.
- Make sure that only clean, approved brake fluid from a tightly sealed container is used.



WARNING

Danger of accidents An insufficient brake fluid level will cause the brake system to fail.

If the brake fluid level drops below the specified marking or the specified value, the brake system has a leak or the brake pads are worn down.

- Have the brake system checked and make sure that the problem has been eliminated before the vehicle is used again.



WARNING

Health hazard Brake fluid is a harmful substance.

- Keep brake fluid out of the reach of children.
- Wear suitable protective clothing and safety glasses.
- Do not allow brake fluid to come into contact with the skin, the eyes, or clothing.
- Consult a doctor immediately if brake fluid has been ingested.
- Rinse the affected area with plenty of water in the event of contact with the skin.
- Rinse eyes thoroughly with water immediately and consult a doctor if brake fluid comes into contact with the eyes.
- If brake fluid spills on to your clothing, change the clothing.



NOTE

Environmental hazard Hazardous substances cause environmental damage.

- Dispose of oils, grease, filters, fuel, cleaning agents, brake fluid, etc. correctly and in accordance with the applicable regulations.



Note

Avoid contact between brake fluid and painted parts. Brake fluid corrodes paint.

Preparatory work

- Check that the brake pads of the rear brake are secured.
 (p. 76)

Main work

Condition: Screw cap is locked

- Remove screw **1** and take off the screw cap lock.

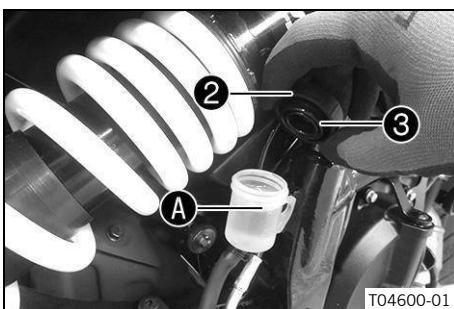
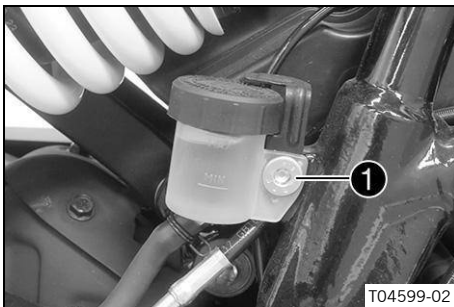

- Stand the vehicle upright.
- Remove screw cap **2** with membrane **3**.
- Add brake fluid up to the marking **A**.

Brake fluid DOT 5.1  (p. 129)

- Mount the screw cover with the membrane.

Immediately clean up any brake fluid that has overflowed or spilled with water.

Condition: Screw cap is locked

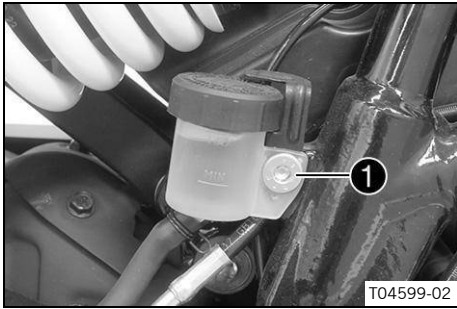

T04599-02

- Position the screw cap lock and mount and tighten screw ①.

Screw, compensating tank cap lock, rear brake	
M6	7 Nm (5.2 ft·lb _f)

13.8 Checking that the brake pads of the rear brake are secured



WARNING

Danger of accidents Worn brake pads reduce the brake action.

- Make sure that worn brake pads are replaced immediately.



WARNING

Danger of accidents Damaged brake discs reduce the braking action. If the brake linings are not changed in time, the brake lining carriers grind against the brake disc. As a consequence, the brake action is greatly reduced and the brake discs are destroyed.

- Check the brake linings regularly.

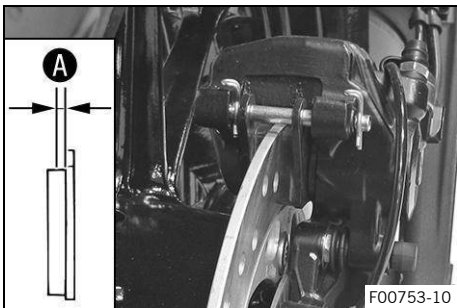

F00753-10



- Check the brake linings for lining thickness ①.

Minimum thickness ①	≥ 1 mm (≥ 0.04 in)
---------------------	-----------------------

- » If it is less than the minimum thickness:
 - Change the rear brake pads. 🔧
- Check the brake pads for damage and cracking.
 - » If there is damage or cracking:
 - Change the rear brake pads. 🔧
- Check that the brake pads are secured.
 - » If the brake pads are not secured correctly:
 - Secure brake pads, replace with new parts if necessary.

14.1 Removing the front wheel 

Preparatory work

- Raise the motorcycle with the rear lifting gear.  (p. 62)
- Lift the motorcycle with the front lifting gear.  (p. 62)

Main work

- Remove screw **1** and pull wheel speed sensor **2** out of the hole.
- Loosen screw **3** by several rotations.
- Loosen screws **4**.
- Press on screw **3** to push the wheel spindle out of the axle clamp.
- Remove screw **3**.

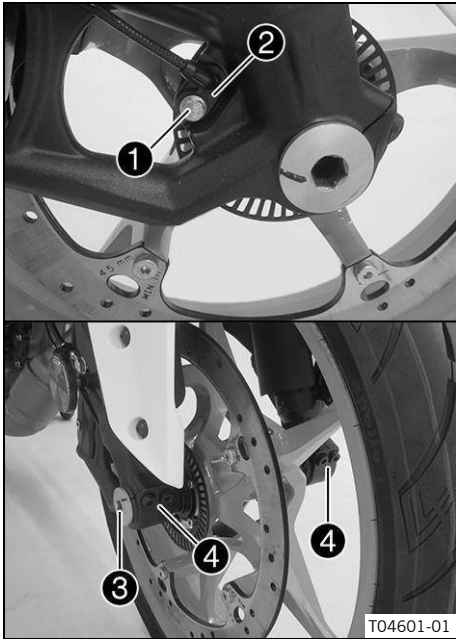

WARNING

Danger of accidents Damaged brake discs reduce the braking action.

- Always lay the wheel down in such a way that the brake disc is not damaged.

- Hold front wheel and remove wheel spindle. Take the front wheel out of the fork.

Do not actuate the hand brake lever when the front wheel is removed.

14.2 Installing the front wheel 





WARNING

Danger of accidents Oil, grease or wax on the brake discs reduces the brake action.

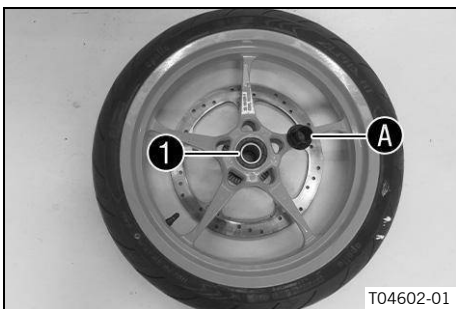
- Always keep the brake discs free of oil, fat and wax.
- Clean the brake discs with brake cleaner when necessary.



- Check the wheel bearing for damage and wear.
 - » If the wheel bearing is damaged or worn:
 - Change the front wheel bearing. 
- Clean and grease radial shaft seal **1** and contact surfaces **A** on the spacers.

Long-life grease  (p. 129)

- Insert spacers.

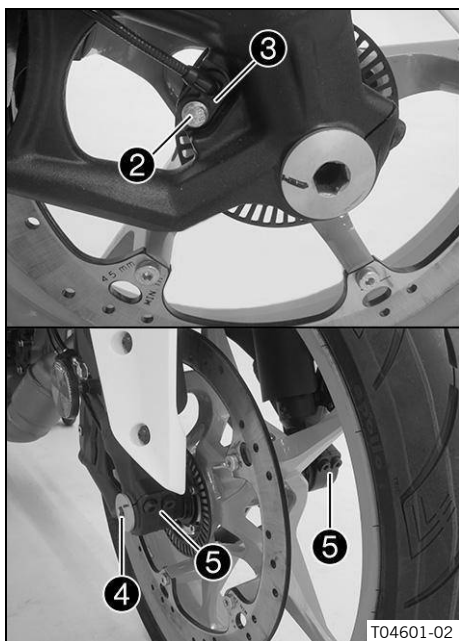

- Clean the thread of the wheel spindle and screw ④.
- Clean and grease wheel spindle.

Long-life grease (p. 129)

- Position the front wheel and insert the wheel spindle.
✓ The brake pads are positioned correctly.
- Mount and tighten screw ④.

Screw, wheel spindle, front	
-----------------------------	--

M24	45 Nm (33.2 ft·lb _f)
-----	-------------------------------------

- Position wheel speed sensor ③ in the hole.
- Mount and tighten screw ②.

Screw, wheel speed sensor holder	
----------------------------------	--

M6	9 Nm (6.6 ft·lb _f)
----	-----------------------------------

- Operate the hand brake lever repeatedly until the brake pads are in contact with the brake disc and a pressure point is reached.
- Take the motorcycle off the front lifting gear. (p. 63)
- Remove the rear of the motorcycle from the lifting gear. (p. 62)
- Operate the front brake and compress the fork a few times firmly.
✓ The fork legs straighten.
- Tighten screws ⑤.

Screw, fork shoe	
------------------	--

M8	15 Nm (11.1 ft·lb _f)
----	-------------------------------------

14.3 Removing the rear wheel

Preparatory work

- Raise the motorcycle with the rear lifting gear. (p. 62)

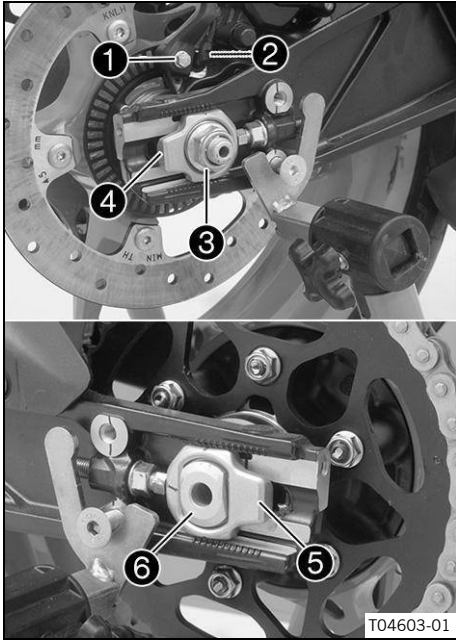

Main work

- Remove screw **1** and pull wheel speed sensor **2** out of the hole.
- Remove nut **3** and washer.
- Take off chain adjuster **4**.
- Holding the rear wheel, withdraw wheel spindle **6** with the washer and chain adjuster **5**.
- Push the rear wheel forward as far as possible and take the chain off the rear sprocket.
- Carefully push the brake caliper support to the side, do not damage the brake line.



WARNING

Danger of accidents Damaged brake discs reduce the braking action.

- Always lay the wheel down in such a way that the brake disc is not damaged.

- Pull the rear wheel back and take it out of the link fork.

Do not actuate the brake pedal when the rear wheel is removed.

14.4 Installing the rear wheel



WARNING

Danger of accidents Oil, grease or wax on the brake discs reduces the brake action.

- Always keep the brake discs free of oil, fat and wax.
- Clean the brake discs with brake cleaner when necessary.



WARNING

Danger of accidents There is no braking effect to start with at the rear brake after installing the rear wheel.

- Actuate the foot brake several times before going on a ride until you can feel a firm pressure point.

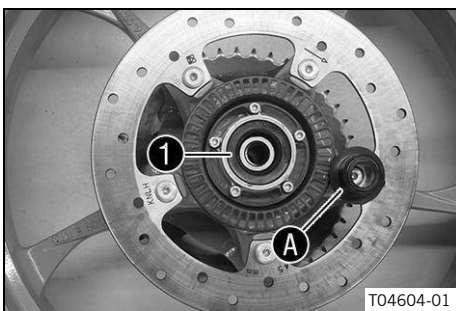

Main work

- Check the rear hub damping rubber pieces. (p. 80)
- Check the wheel bearing for damage and wear.
 - » If the wheel bearing is damaged or worn:
 - Change the rear wheel bearing.
- Clean and grease radial shaft seal **1** and contact surfaces **A** on the spacers.

Long-life grease (p. 129)
- Clean the thread of the wheel spindle and axle nut.
- Clean and grease wheel spindle.

Long-life grease (p. 129)
- Clean the contact areas on the brake caliper bracket and link fork.
- Mount the damping rubber and rear sprocket carrier on the rear wheel.

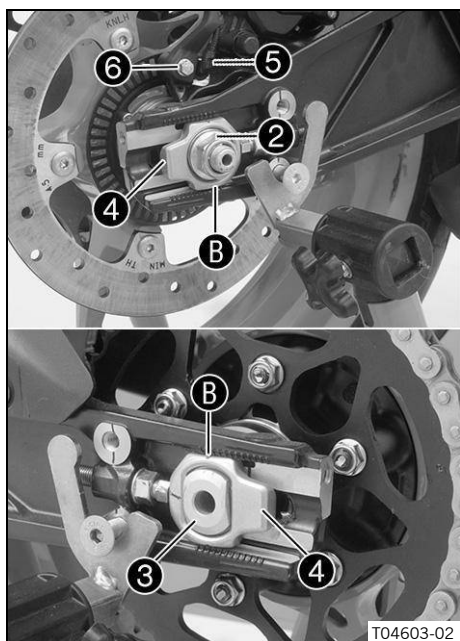

- Position the rear wheel.
 - ✓ Brake pads and brake caliper supports are correctly positioned.
- Push the rear wheel forward as far as possible and lay the chain on the rear sprocket.
- Pull the rear wheel back and mount wheel spindle ③ with the washer and chain adjuster ④.

Mount left and right chain adjusters ④ in the same position.

- Mount nut ② and the washer.
- Push the rear wheel forward so that the chain adjusters are in contact with the screws, and tighten nut ②.

In order for the rear wheel to be correctly aligned, the markings on the left and right chain adjusters must be in the same position relative to reference markings B.

Nut, wheel spindle, rear	
M16	100 Nm (73.8 ft·lb _f)

- Position wheel speed sensor ⑤ in the hole.
- Mount and tighten screw ⑥.

Screw, wheel speed sensor holder	
M6	9 Nm (6.6 ft·lb _f)

Reworking

- Remove the rear of the motorcycle from the lifting gear. (p. 62)
- Check the chain tension. (p. 67)

14.5 Checking the rear hub damping rubber pieces

Note

The engine power is transmitted from the rear sprocket to the rear wheel via the six damping rubber pieces. They eventually wear out during operation. If the damping rubber pieces are not changed in time, the rear sprocket carrier and the rear hub will be damaged.

Preparatory work

- Raise the motorcycle with the rear lifting gear. (p. 62)
- Remove the rear wheel. (p. 78)

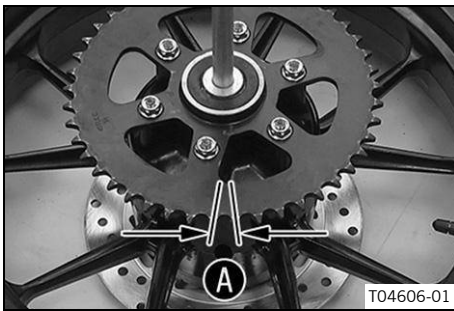
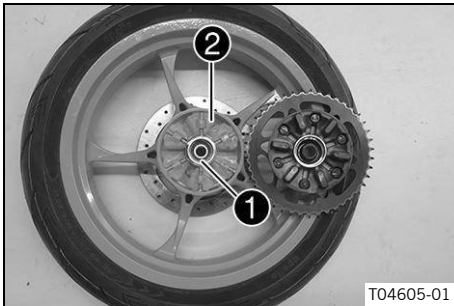

Main work

- Check bearing ①.
 - » If the bearing is damaged or worn:
 - Change the bearings. 🛠️
- Check damping rubber pieces ② of the rear hub for damage and wear.
 - » If the damping rubber pieces of the rear hub are damaged or worn:
 - Change all the damping rubber pieces of the rear hub.
- Lay the rear wheel on a workbench with the rear sprocket facing upward and insert the wheel spindle in the hub.
- To check play A, hold the rear wheel tight and try to rotate the rear sprocket.

Measure the play on the outside of the rear sprocket.	
Play of damping rubber pieces on rear wheel	≤ 5 mm (≤ 0.20 in)

- » If clearance A is larger than the specified value:
 - Change all the damping rubber pieces of the rear hub.

Reworking

- Install the rear wheel. 🛠️ 📖 (p. 79)
- Remove the rear of the motorcycle from the lifting gear. 📖 (p. 62)
- Check the chain tension. 📖 (p. 67)

14.6 Checking the tire condition

WARNING
Danger of accidents If a tire bursts while riding, the vehicle becomes uncontrollable.
 - Ensure that damaged or worn tires are replaced immediately.

WARNING
Danger of accidents Non-approved or non-recommended tyres and wheels impact the handling characteristic.
 - Only use tires and wheels approved and recommended by the vehicle manufacturer with the corresponding speed rating.

WARNING
Danger of accidents Different tire profiles on the front and rear wheels can make it more difficult to control the vehicle.
 - Make sure that only tires of the same tread type are mounted to the front and rear wheel.

Note
 The type, condition, and pressure of the tires all have a major impact on the handling of the motorcycle. Worn tires have a negative effect on handling characteristics, especially on wet surfaces.

14 Wheels, tires

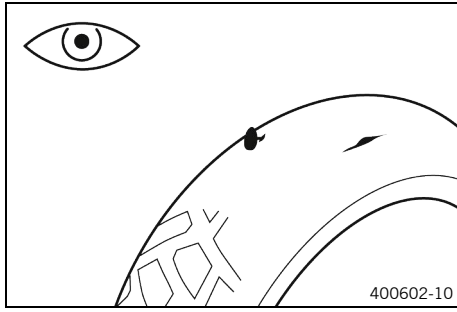

- Check the front and rear tires for cuts, embedded objects, and other damage.
 - » If the tires have cuts, run-in objects, or other damage:
 - Change the tires. 🛠️
- Check the tread depth.

Minimum tread depth	≥ 2 mm (≥ 0.08 in)
---------------------	-----------------------

i Note
Observe the minimum tread depth required by national law.

- » If the tread depth is less than the minimum tread depth:
 - Change the tires. 🛠️

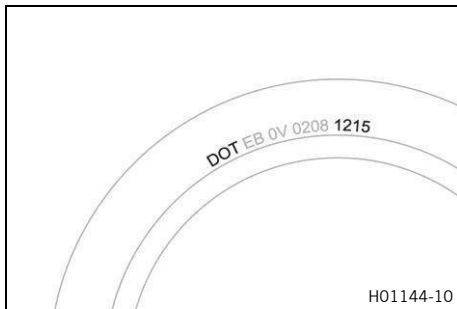

- Check the tire age.

i Note
The tire date of manufacture is usually contained in the tire label and is indicated by the last four digits of the **DOT** number. The first two digits indicate the week of manufacture and the last two digits the year of manufacture.
KTM recommends that the tires be changed after 5 years at the latest, regardless of the actual state of wear.

- » If the tires are older than five years:
 - Change the tires. 🛠️

14.7 Checking the tire pressure

i Note
Low tire pressure leads to abnormal wear and overheating of the tire.
Correct tire pressure ensures optimal riding comfort and maximum tire service life.

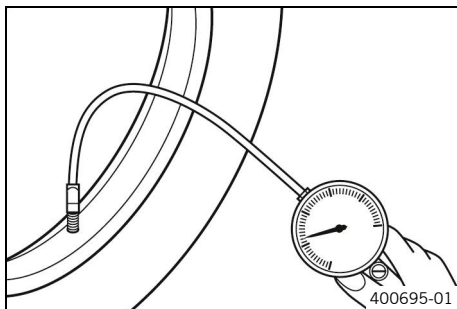

- Remove the protection cap.
- Check the tire pressure when the tires are cold.

Tire pressure when solo	
front	2.0 bar (29.0 psi)
rear	2.2 bar (31.9 psi)

Tire pressure with passenger / full payload	
front	2.0 bar (29.0 psi)
rear	2.2 bar (31.9 psi)

- » If the tire pressure does not meet specifications:
 - Correct tire pressure.
- Mount the protection cap.

15.1 Removing the 12 V battery





WARNING

Risk of injury Battery acid and battery gases cause chemical burns.

- Keep 12-V batteries out of the reach of children.
- Wear suitable protective clothing and safety glasses.
- Avoid contact with battery acid and battery gases.
- Keep sparks or open flames away from the 12 V battery.
- Only charge 12 V batteries in well-ventilated rooms.
- Rinse the affected area immediately with plenty of water in the event of contact with skin.
- Rinse eyes with water for at least 15 minutes and consult a doctor immediately if battery acid and battery gases get into the eyes.

Preparatory work

- Remove the passenger seat.  (p. 64)
- Remove the front rider's seat.  (p. 65)

Main work

- Remove battery cover **A**.

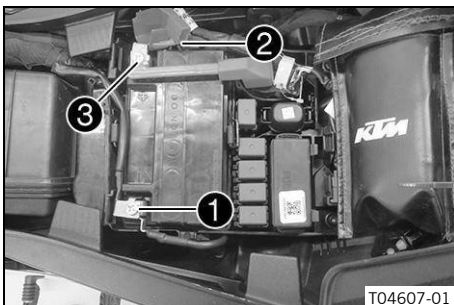
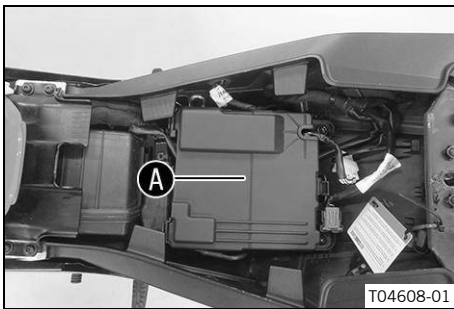

- Disconnect negative cable **1** from the 12 V battery.
- Pull back positive terminal cover **2**.
- Disconnect positive cable **3** from the 12-V battery.
- Pull the 12-V battery upwards and out of the battery compartment.



Note

Never operate the motorcycle with a discharged 12-V battery or without a 12-V battery. In both cases, electrical components and safety devices can be damaged. The vehicle will therefore no longer be roadworthy.

15.2 Installing the 12 V battery

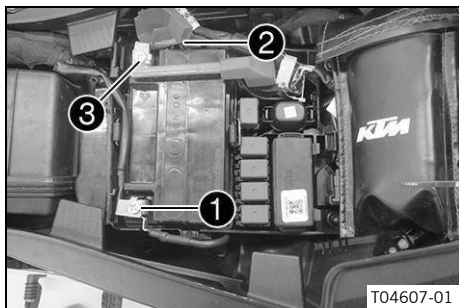

Main work

- Position the 12-V battery in the battery compartment.

12 V battery (ETZ-9-BS)  (p. 131)
--

- Position positive cable **2** and mount and tighten the screw.

Screw, battery terminal	
-------------------------	--

M6	4.5 Nm (3.32 ft·lb _f)
----	--------------------------------------

- Position positive terminal cover **3**.
- Position negative cable **1** and mount and tighten the screw.



Screw, battery terminal	
-------------------------	--

M6	4.5 Nm (3.32 ft·lb _f)
----	--------------------------------------

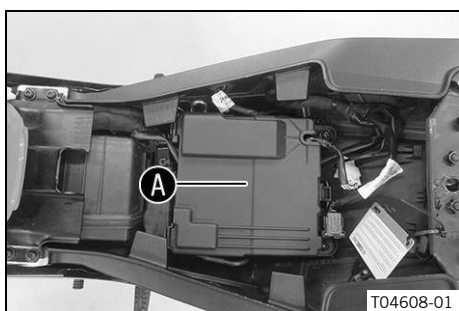
- Mount battery cover **A**.



Reworking

- Mount the front rider's seat.  (p. 65)
- Mount the passenger seat.  (p. 65)
- Set time and date.  (p. 44)

15.3 Charging the 12 V battery



WARNING

Risk of injury Battery acid and battery gases cause chemical burns.

- Keep 12-V batteries out of the reach of children.
- Wear suitable protective clothing and safety glasses.
- Avoid contact with battery acid and battery gases.
- Keep sparks or open flames away from the 12 V battery.
- Only charge 12 V batteries in well-ventilated rooms.
- Rinse the affected area immediately with plenty of water in the event of contact with skin.
- Rinse eyes with water for at least 15 minutes and consult a doctor immediately if battery acid and battery gases get into the eyes.



NOTE

Environmental hazard 12-V batteries contain environmentally-hazardous materials.

- Do not dispose of 12-V batteries as household waste.
- Dispose of 12-V batteries at a collection point for used batteries.



NOTE

Environmental hazard Hazardous substances cause environmental damage.

- Dispose of oils, grease, filters, fuel, cleaning agents, brake fluid, etc. correctly and in accordance with the applicable regulations.



Note

Even when there is no load on the 12-V battery, it discharges steadily each day. The state of charge and the method of charging are very important for the service life of the 12 V battery. Rapid recharging with a high charging current shortens the service life of the battery. If the charging current, charging voltage, or charging time is exceeded, electrolyte escapes through the safety valves. This reduces the capacity of the 12-V battery. If the 12-V battery is left in a discharged state for an extended period, it will become deeply discharged and sulfating occurs, destroying the battery. The 12 V battery is maintenance-free. The acid level does not have to be checked.

Preparatory work

- Remove the passenger seat. (p. 64)
- Remove the front rider's seat. (p. 65)
- Disconnect the negative cable of the 12-V battery to avoid damage to the onboard electronics.

Main work

- Remove battery cover .

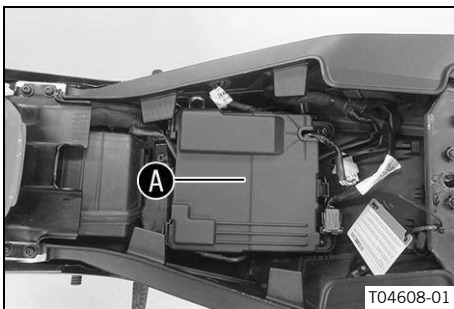

- Connect a charger to the 12 V battery. Connect the battery charger to the mains connection.

EU battery charger TecMATE Optimate PRO (A61029974044)
Work material (Alternative 1 / 2)
USA/CA battery charger TecMATE Optimate PRO (A61029974144)
Work material (Alternative 2 / 2)
Battery charger TecMATE Optimate PRO UK (A61029974244)



Note

After charging, the battery charger can remain on the vehicle, ensuring that the battery voltage is maintained during the maintenance charging cycle.



Note

It is impossible to overcharge the 12-V battery using this battery charger.

- Switch off the charger after charging and disconnect from the 12 V battery.



The charging current, charging voltage, and charging time must not be exceeded.	
If the 12 V battery is depleted from starting the vehicle repeatedly, the battery must be charged immediately.	
Recharge the 12 V battery regularly when the motorcycle is not being used.	3 months

- Position the negative cable and mount and tighten the screw.

Screw, battery terminal	
M6	4.5 Nm (3.32 ft·lb _f)

- Position the negative terminal cover.

Reworking

- Mount the front rider's seat.  (p. 65)
- Mount the passenger seat.  (p. 65)
- Set time and date.  (p. 44)

15.4 Changing the main fuse



WARNING

Fire hazard Incorrect fuses overload the electrical system.



- Use only fuses with the prescribed amperage.
- Do not bypass or repair fuses.



Note

The main fuse protects all electrical power loads of the vehicle. The main fuse is under the front rider's seat.

Preparatory work

- Remove the passenger seat.  (p. 64)
- Remove the front rider's seat.  (p. 65)

Main work

- Remove battery cover .

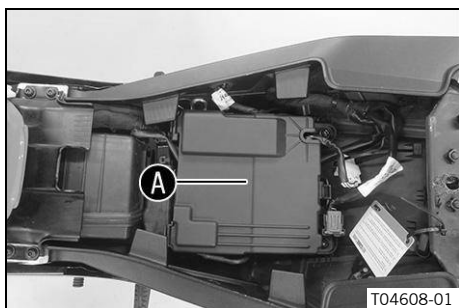

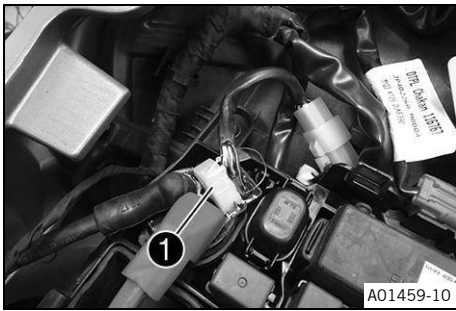

- Remove protection cap ①.

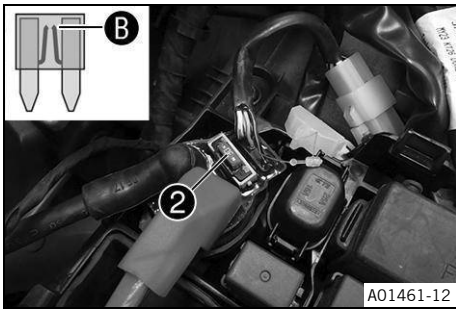

- Remove faulty main fuse ②.



Note

A faulty fuse has a burned-out fuse wire ③.
A spare fuse is located in the fuse box.

- Insert the main fuse.

Fuse (75011088030) 📖 (p. 132)



Tip

Put a spare fuse in the fuse box so that it is available if needed.

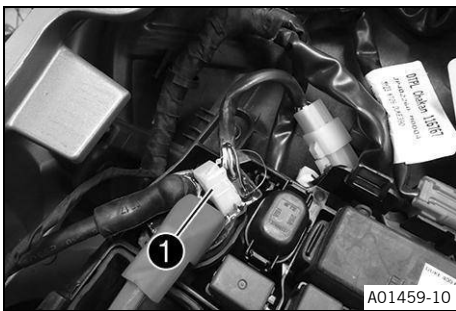

- Mount protection cap ①.

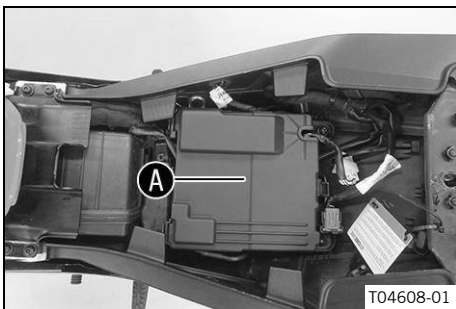

- Mount battery cover ④.

Reworking

- Mount the front rider's seat. 📖 (p. 65)
- Mount the passenger seat. 📖 (p. 65)
- Set time and date. 📖 (p. 44)



15.5 Changing the ABS fuses



WARNING

Fire hazard Incorrect fuses overload the electrical system.

- Use only fuses with the prescribed amperage.
- Do not bypass or repair fuses.



Note

Two fuses for the ABS are located under the passenger seat. These fuses protect the return pump and the hydraulic unit of the ABS. The third fuse, which protects the ABS control unit, is located in the fuse box.

Preparatory work

- Remove the passenger seat. (p. 64)
- Remove the front rider's seat. (p. 65)
- Remove the battery cover.

Main work

To change the fuse of the ABS hydraulic unit:

- Take off the protection cap and remove fuse ①.



Note

A faulty fuse has a burned-out fuse wire **A**.

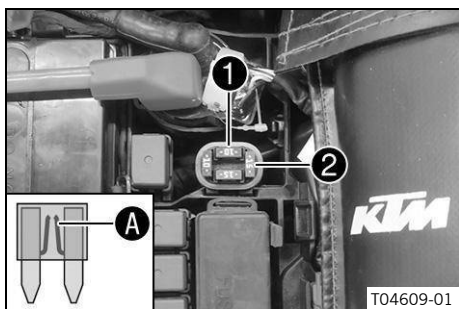

WARNING

Fire hazard Incorrect fuses overload the electrical system.

- Use only fuses with the prescribed amperage.
- Do not bypass or repair fuses.

- Insert the spare fuse with the correct rating.

Fuse (75011088010) (p. 132)



Tip

Insert spare fuse ② in the fuse box so that it is available if needed.

- Mount the protection cap.

To change the fuse of the ABS return pump:

- Take off the protection cap and remove fuse ③.



Note

A faulty fuse has a burned-out fuse wire **A**.

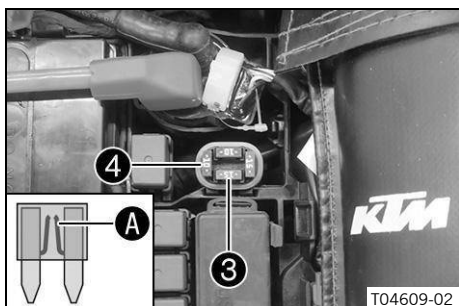

WARNING

Fire hazard Incorrect fuses overload the electrical system.

- Use only fuses with the prescribed amperage.
- Do not bypass or repair fuses.

- Insert the spare fuse with the correct rating.

Fuse (75011088015)  (p. 132)





Tip

Insert spare fuse ④ in the fuse box so that it is available if needed.

- Mount the protection cap.

Reworking

- Mount the battery cover.
- Mount the front rider's seat.  (p. 65)
- Mount the passenger seat.  (p. 65)





15.6 Changing the fuses of individual electrical power consumers



Note

The fuse box with the main fuse and the fuses of the individual electrical power consumers is located under the passenger seat.

Preparatory work

- Remove the passenger seat.  (p. 64)
- Remove the front rider's seat.  (p. 65)

Main work

- Remove battery cover ①.

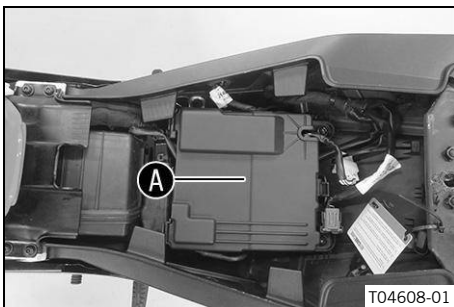

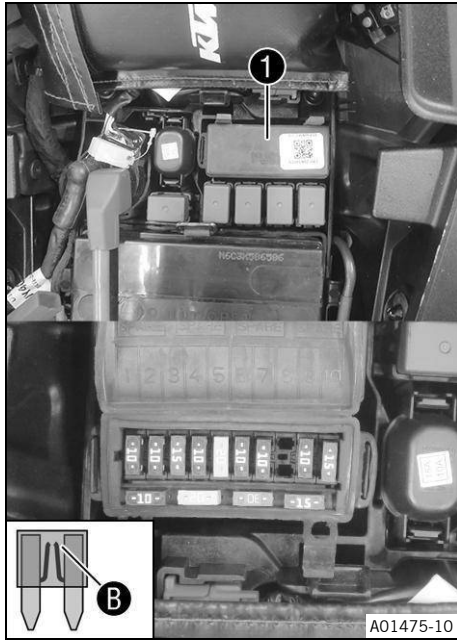

- Open fuse box cover **1**.
- Remove the faulty fuse.

Fuse 1 - 10 A - combination instrument, brake light, high beam, tail light
Fuse 2 - 10 A - combination instrument
Fuse 3 - 15 A - main relay
Fuse 4 - 10 A - start auxiliary relay, horn
Fuse 5 - 20 A - radiator fan
Fuse 6 - 10 A - headlight unit, parking light, license plate lamp
Fuse 7 - 10 A - engine control unit, ABS control unit, Connectivity Unit
Fuse 8 - not assigned
Fuse 9 - 10 A - permanent positive for accessories (ACC1)
Fuse 10 - 10 A - ignition positive for accessory (ACC2), USB charging port
Fuse SPARE - 10 A/15 A/20 A/30 A - spare fuses



Note

A faulty fuse has a burned-out fuse wire **B**.







WARNING

Fire hazard Incorrect fuses overload the electrical system.

- Use only fuses with the prescribed amperage.
- Do not bypass or repair fuses.

- Insert the spare fuse with the correct rating.

Fuse (75011088010)  (p. 132)
Fuse (75011088015)  (p. 132)
Fuse (75011088020)  (p. 132)
Fuse (75011088030)  (p. 132)



Tip

Put a spare fuse in the fuse box so that it is available if needed.

- Check the function of the electrical power consumer.
- Close the fuse box cover **1**.
- Mount battery cover **A**.

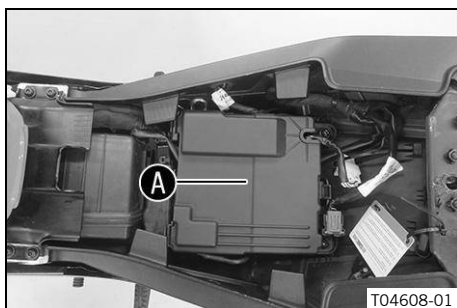

Reworking

- Mount the front rider's seat. 📖 (p. 65)
- Mount the passenger seat. 📖 (p. 65)



15.7 Checking the headlight setting

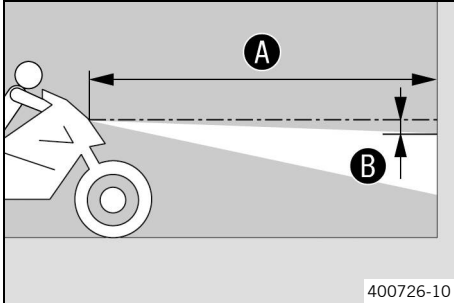

- Park the vehicle on a horizontal surface in front of a light-colored wall and make a mark at the height of the center of the low beam headlight.
- Make another mark at a distance **B** under the first marking.

Distance B	5 cm (2.0 in)
-------------------	------------------

- Position the vehicle upright at distance **A** from the wall and switch on the low beam.

Distance A	5 m (16 ft – 5 in)
-------------------	-----------------------

- Get on the motorcycle, together with any luggage or passenger.
- Check the headlight adjustment.

The light-dark boundary must lie exactly on the lower marking when the motorcycle is ready to operate with the rider mounted along with any luggage and a passenger if applicable.

- » If the boundary between light and dark does not meet specifications:
 - Adjust headlight range. 📖 (p. 91)



15.8 Adjusting the headlight range

Preparatory work

- Check the headlight adjustment. 📖 (p. 91)

Main work

- Turn adjusting screw **1** to adjust the headlight range.

Screw **1** also secures the headlight. Ensure the screw is always screwed in far enough.

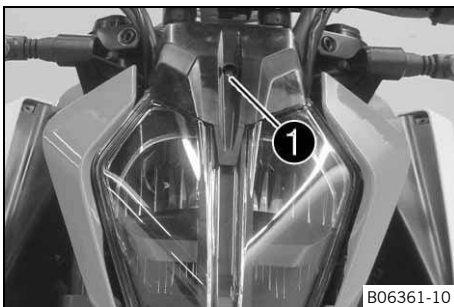

i Note
Turn clockwise to increase the headlight range; turn counterclockwise to reduce the headlight range.
If you have a load, you may have to correct the headlight range of the auxiliary headlights.

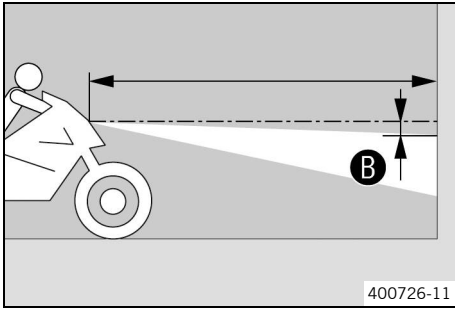

- Set the headlight to marking **B**.

The light-dark boundary must lie exactly on lower marking **B** when the motorcycle is ready to operate with the rider mounted along with any luggage and a passenger if applicable.

15.9 Diagnostic connector

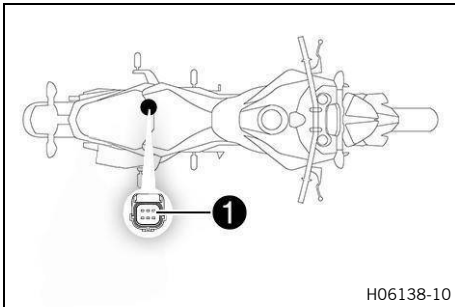

Diagnostics connector **1** is located under the passenger seat.

15.10 Front ACC1 and ACC2

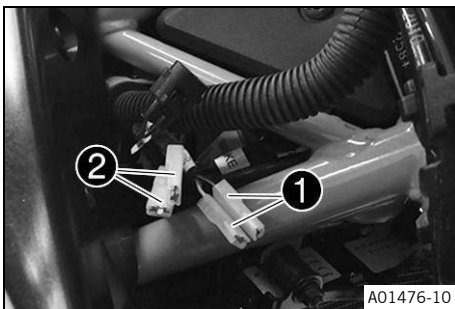

Installation location

- The ACC1 **1** and ACC2 **2** power supplies are located on the right of the vehicle at the front, behind the steering head cover.

15.11 Rear ACC1 and ACC2

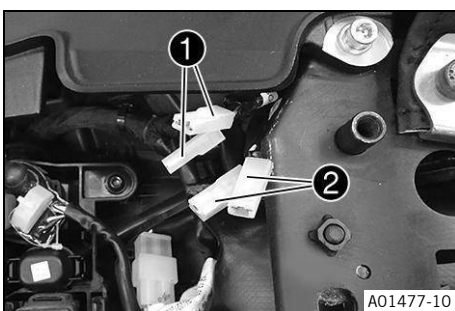

Installation location

- The ACC1 **1** and ACC2 **2** power supplies are located at the rear under the front rider's seat.

16.1 Cooling system

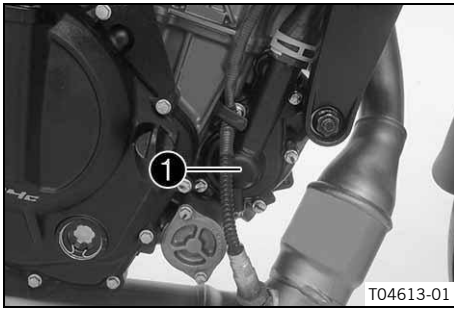

Water pump ① in the engine circulates the coolant. The pressure resulting from the warming of the cooling system is regulated by a valve in radiator cap ②. Heat expansion causes excess coolant to flow into compensating tank ③. When the temperature falls, this surplus coolant is sucked back into the cooling system.

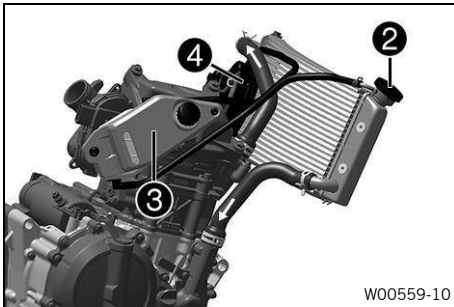

The coolant is cooled by the air stream and a radiator fan ④, which is activated at high temperature. The lower the vehicle speed, the lower the cooling effect. Dirty cooling fins also reduce the cooling effect.

Note

If the cooling system overheats, the maximum engine speed is limited.

16.2 Checking the frost protection and coolant level



WARNING

Health hazard Coolant is harmful to health.

- Keep coolant out of the reach of children.
- Do not allow coolant to come into contact with skin, eyes, or clothing.
- Consult a doctor immediately if coolant has been ingested.
- Rinse the affected area immediately with plenty of water in the event of contact with skin.
- Rinse eyes thoroughly with water and consult a doctor immediately if coolant comes into contact with eyes.
- If coolant spills on to your clothing, change the clothing.
- Store coolant properly in a suitable container and keep out of the reach of children.



WARNING

Danger of scalding The coolant heats up and is under high pressure when the vehicle is operated.

- Do not open the radiator, the radiator hoses, or other cooling system components if the engine or the cooling system are at operating temperature.
- Allow the cooling system and the engine to cool down before you open the radiator, the radiator hoses, or other components of the cooling system.
- In the event of scalding, rinse the area affected immediately with lukewarm water.

Condition: The engine is cold

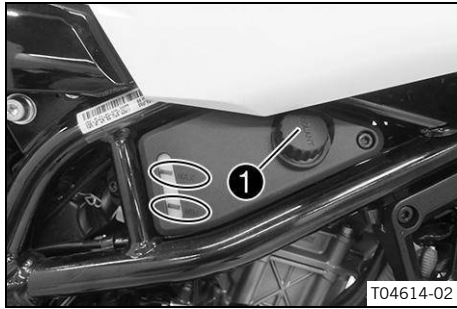

- Stand the motorcycle upright on a level surface.
- Remove cap ❶ of the compensating tank.
- Check the frost protection in the coolant.

-45 °C ... -25 °C (-49.0 °F ... -13.0 °F)
--

- » If the frost protection in the coolant does not match the specified value:
 - Correct the frost protection in the coolant.
- Check the coolant level in the compensating tank.

The coolant level must be between the two markings.

- » If the coolant level does not meet the specifications:
 - Correct the coolant level.

Coolant	
Coolant 📖 (p. 130) Antifreeze protection to at least: -25 °C (-13.0 °F)	1.2 l (0.32 liq. gal _{US})

- Mount the cap of the compensating tank.
- Remove radiator cap ❷.
- Check the frost protection in the coolant.

-45 °C ... -25 °C (-49.0 °F ... -13.0 °F)
--

- » If the frost protection in the coolant does not match the specified value:
 - Correct the frost protection in the coolant.
- Check the coolant level in the radiator.

The radiator must be filled completely.

- » If the coolant level does not meet the specifications:
 - Check the coolant level and the reason for the loss.

Coolant	
Coolant 📖 (p. 130) Antifreeze protection to at least: -25 °C (-13.0 °F)	1.2 l (0.32 liq. gal _{US})

- » If you had to add more coolant than the specified amount:
 - > 0.20 l
(> 0.053 liq. gal_{US})
 - Fill/bleed the cooling system. 🛠️ 📖 (p. 96)

- Mount the radiator cap.

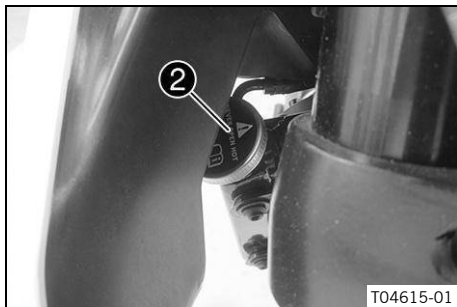

16.3 Checking the coolant level



WARNING

Health hazard Coolant is harmful to health.

- Keep coolant out of the reach of children.
- Do not allow coolant to come into contact with skin, eyes, or clothing.
- Consult a doctor immediately if coolant has been ingested.
- Rinse the affected area immediately with plenty of water in the event of contact with skin.
- Rinse eyes thoroughly with water and consult a doctor immediately if coolant comes into contact with eyes.
- If coolant spills on to your clothing, change the clothing.
- Store coolant properly in a suitable container and keep out of the reach of children.



WARNING

Danger of scalding The coolant heats up and is under high pressure when the vehicle is operated.

- Do not open the radiator, the radiator hoses, or other cooling system components if the engine or the cooling system are at operating temperature.
- Allow the cooling system and the engine to cool down before you open the radiator, the radiator hoses, or other components of the cooling system.
- In the event of scalding, rinse the area affected immediately with lukewarm water.

Condition: The engine is cold

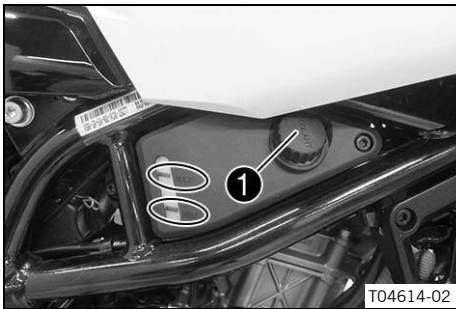

- Stand the motorcycle upright on a level surface.
- Check the coolant level in compensating tank ①.

The coolant level must be between the two markings.

» If the coolant level does not meet the specifications:

- Correct the coolant level.

Coolant	
Coolant (p. 130)	1.2 l
Antifreeze protection to at least: -25 °C (-13.0 °F)	(0.32 liq. gal _{US})



- Remove radiator cap ② and check the coolant level in the radiator.

The radiator must be filled completely.

» If the coolant level does not meet the specifications:

- Check the coolant level and the reason for the loss.

» If you had to add more coolant than the specified amount:

> 0.20 l
(> 0.053 liq. gal_{US})

- Fill/bleed the cooling system. (p. 96)

- Mount the radiator cap.

16.4 Draining the coolant



WARNING

Health hazard Coolant is harmful to health.

- Keep coolant out of the reach of children.
- Do not allow coolant to come into contact with skin, eyes, or clothing.
- Consult a doctor immediately if coolant has been ingested.
- Rinse the affected area immediately with plenty of water in the event of contact with skin.
- Rinse eyes thoroughly with water and consult a doctor immediately if coolant comes into contact with eyes.
- If coolant spills on to your clothing, change the clothing.
- Store coolant properly in a suitable container and keep out of the reach of children.



WARNING

Danger of scalding The coolant heats up and is under high pressure when the vehicle is operated.

- Do not open the radiator, the radiator hoses, or other cooling system components if the engine or the cooling system are at operating temperature.
- Allow the cooling system and the engine to cool down before you open the radiator, the radiator hoses, or other components of the cooling system.
- In the event of scalding, rinse the area affected immediately with lukewarm water.

Condition: The engine is cold

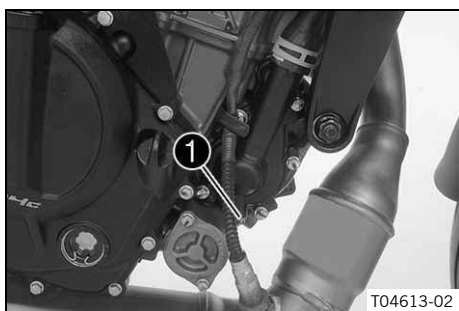

- Stand the motorcycle upright.
- Position an appropriate container under the engine.
- Remove screw ❶.
- Remove the radiator cap.
- Completely drain the coolant.
- Mount screw ❶ with the new sealing ring and tighten.

Screw plug, water pump drain hole	
M6	11 Nm (8.1 ft·lb _f)
	Loctite® 243

16.5 Filling/bleeding the cooling system



WARNING

Health hazard Coolant is harmful to health.

- Keep coolant out of the reach of children.
- Do not allow coolant to come into contact with skin, eyes, or clothing.
- Consult a doctor immediately if coolant has been ingested.
- Rinse the affected area immediately with plenty of water in the event of contact with skin.
- Rinse eyes thoroughly with water and consult a doctor immediately if coolant comes into contact with eyes.
- If coolant spills on to your clothing, change the clothing.
- Store coolant properly in a suitable container and keep out of the reach of children.

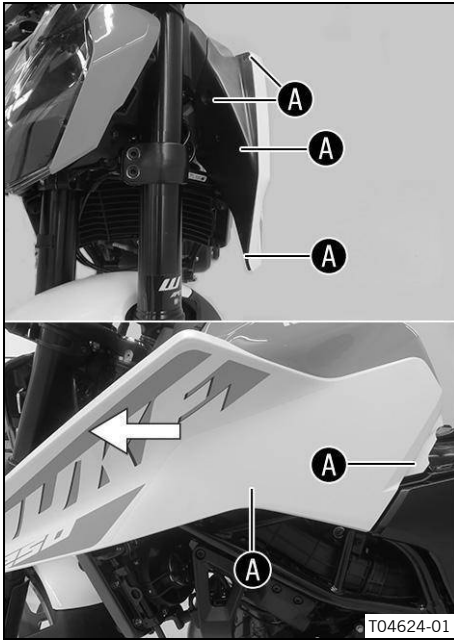

- Remove screws **A** on the left fuel tank cover. Slide tank cover forward and remove it.



- Remove radiator cap **1**.

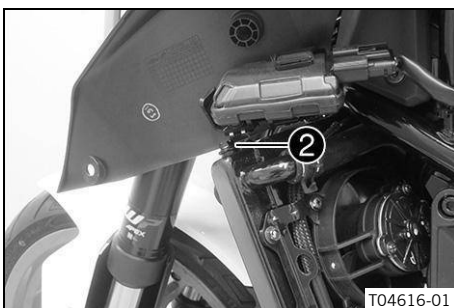

- Loosen bleeder screw **2**.

3 turns (1,080°)

- Tilt the vehicle slightly to the right.
- Pour in the coolant until it emerges without bubbles at the bleeder screw, and then mount and tighten the bleeder screw immediately.

Coolant	
Coolant  (p. 130)	1.2 l
Antifreeze protection to at least: -25 °C (-13.0 °F)	(0.32 liq. gal _{US})

- Completely fill the radiator with coolant. Mount the radiator cap.

- Rest the vehicle on the side stand.



DANGER

Danger of poisoning Exhaust gases are toxic and inhaling them may result in unconsciousness and death.

- Always ensure that there is sufficient ventilation when running the engine.
- Use suitable exhaust extraction when starting or running the engine in an enclosed space.

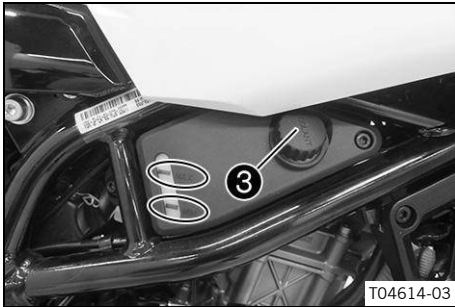

- Start the engine and allow it to warm up.
- Stop the engine and allow it to cool down.
- When the engine is cool, check the coolant level in the radiator and, if necessary, add coolant.
- Remove cap ③ of the compensating tank and top up the coolant level up to the **MAX** marking.
- Mount the cap of the compensating tank.
- Install left tank cover in reverse order to removal.

16.6 Changing the coolant



WARNING

Health hazard Coolant is harmful to health.

- Keep coolant out of the reach of children.
- Do not allow coolant to come into contact with skin, eyes, or clothing.
- Consult a doctor immediately if coolant has been ingested.
- Rinse the affected area immediately with plenty of water in the event of contact with skin.
- Rinse eyes thoroughly with water and consult a doctor immediately if coolant comes into contact with eyes.
- If coolant spills on to your clothing, change the clothing.
- Store coolant properly in a suitable container and keep out of the reach of children.



WARNING

Danger of scalding The coolant heats up and is under high pressure when the vehicle is operated.

- Do not open the radiator, the radiator hoses, or other cooling system components if the engine or the cooling system are at operating temperature.
- Allow the cooling system and the engine to cool down before you open the radiator, the radiator hoses, or other components of the cooling system.
- In the event of scalding, rinse the area affected immediately with lukewarm water.

Condition: The engine is cold

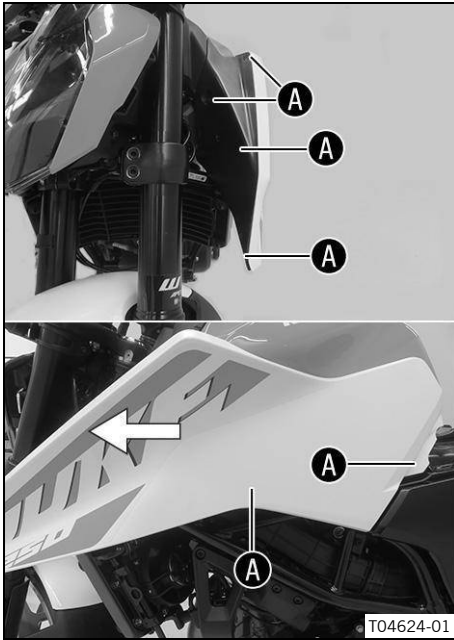

- Remove screws **A** on the left fuel tank cover. Slide tank cover forward and remove it.

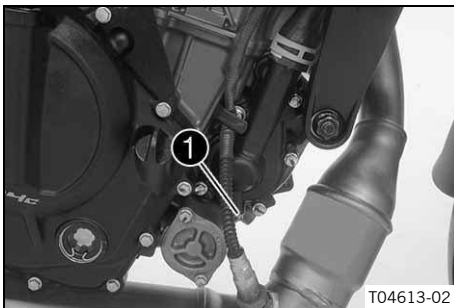

- Stand the motorcycle upright.
- Position an appropriate container under the engine.
- Remove screw **1** with the sealing ring.

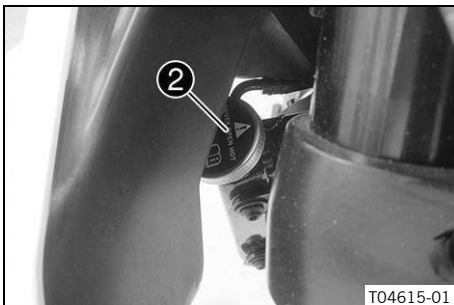

- Remove radiator cap **2**.
- Completely drain the coolant.
- Mount screw **1** with the new sealing ring and tighten.

Screw plug, water pump drain hole	
M6	11 Nm (8.1 ft·lb _f)
	Loctite® 243

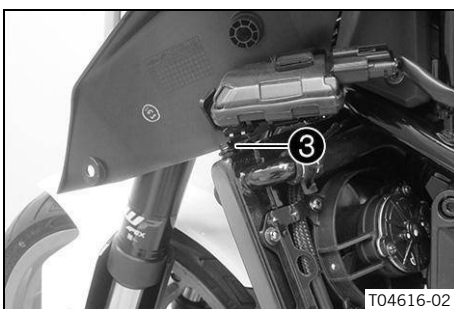

- Loosen bleeder screw **3**.

3 turns (1,080°)

- Tilt the vehicle slightly to the right.
- Pour in the coolant until it emerges without bubbles at the bleeder screw, and then mount and tighten the bleeder screw immediately.

Coolant	
Coolant  (p. 130) Antifreeze protection to at least: -25 °C (-13.0 °F)	1.2 l (0.32 liq. gal _{US})

- Completely fill the radiator with coolant. Mount the radiator cap.
- Rest the vehicle on the side stand.



DANGER

Danger of poisoning Exhaust gases are toxic and inhaling them may result in unconsciousness and death.

- Always ensure that there is sufficient ventilation when running the engine.
- Use suitable exhaust extraction when starting or running the engine in an enclosed space.

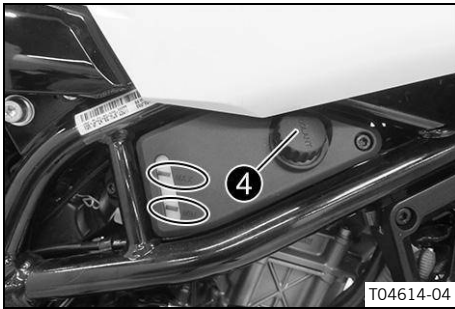

- Start the engine and allow it to warm up.
- Stop the engine and allow it to cool down.
- When the engine is cool, check the coolant level in the radiator and, if necessary, add coolant.
- Remove cap ④ of the compensating tank and top up the coolant level up to the **MAX** marking.
- Mount the cap of the compensating tank.
- Install left tank cover in reverse order to removal.

17.1 Checking the play in the clutch lever



NOTE

Clutch damage If there is no free travel by the clutch lever, the clutch will slip.

- Check the free travel of the clutch lever each time before using the vehicle.
- Adjust the free travel of the clutch lever when necessary in accordance with the specification.

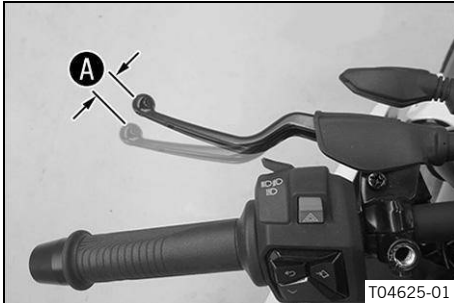

- Check the clutch lever for smooth operation.
- Move the handlebar to the straight-ahead position.
- Pull the clutch lever until resistance is perceptible, and determine the play in the clutch lever **A**.

Clutch lever play A	1 mm ... 3 mm (0.04 in ... 0.12 in)
----------------------------	--

» If the play in the clutch lever does not meet the specified value:

- Adjust play in the clutch lever. (p. 101)

- Move the handlebar back and forth over the entire steering range.

The clutch lever play must not change.

» If the clutch lever play changes:

- Check the routing of the clutch cable.

17.2 Adjusting play in the clutch lever

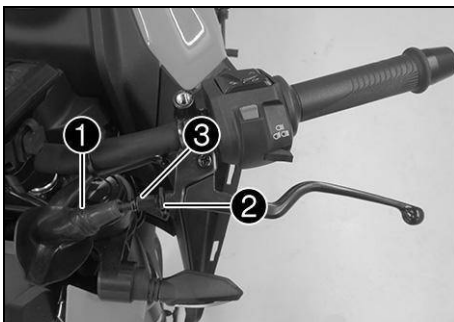

- Move the handlebar to the straight-ahead position.
- Push back sleeve **1**.
- Loosen lock nut **2**.
- Adjust the play in the clutch level **A** by turning adjusting screw **3**.

Clutch lever play A	1 mm ... 3 mm (0.04 in ... 0.12 in)
----------------------------	--

- Tighten lock nut **2**.
- Position bellows **1**.

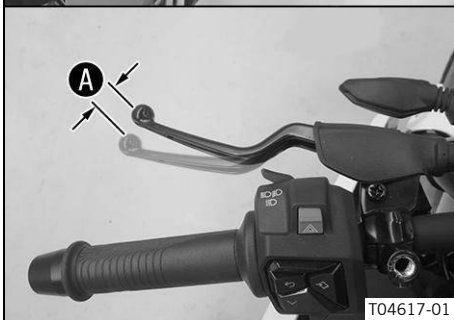

18.1 Checking the engine oil level

Condition: The engine is at operating temperature

Preparatory work

- Stand the motorcycle upright on a level surface.

Main work

- Check the engine oil level.

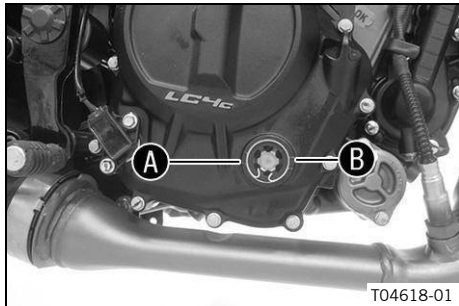

After switching off the engine, wait one minute before checking the level.

The engine oil must be between the **A** and **B** markings .

- » When the engine oil level is below the **A** marking:
 - Add engine oil.  (p. 104)
- » When the engine oil level is above the **B** marking:
 - Correct the engine oil level.

18.2 Changing the engine oil and oil filter, cleaning the oil screens



WARNING

Danger of scalding Engine and gear oil heat up when the motorcycle is operated.

- Wear suitable protective clothing and safety gloves.
- In the event of scalding, rinse the area affected immediately with lukewarm water.



NOTE

Environmental hazard Hazardous substances cause environmental damage.

- Dispose of oils, grease, filters, fuel, cleaning agents, brake fluid, etc. correctly and in accordance with the applicable regulations.



Note

Drain the engine oil while the engine is at operating temperature.

Preparatory work

- Stand the motorcycle on a level surface using the side stand.

Main work

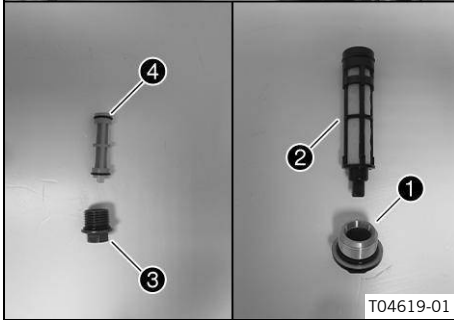
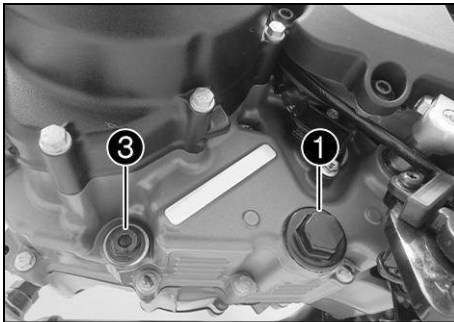

- Position an appropriate container under the engine.
- Remove oil drain plug **1** with the O-ring.
- Remove oil screen **2** with the O-ring.
- Remove screw plug **3** with oil screen **4**.
- Allow the engine oil to drain completely.
- Thoroughly clean the oil drain plugs and oil screens.
- Position oil screen **2** and mount and tighten oil drain plug **1** with the O-ring.

Oil screen screw plug, large	
M24×1.5	12.5 Nm (9.22 ft·lb _r)

- Mount and tighten screw plug **3** with oil screen **4** and the O-ring.

Oil screen screw plug, small	
M17×1.5	11 Nm (8.1 ft·lb _r)

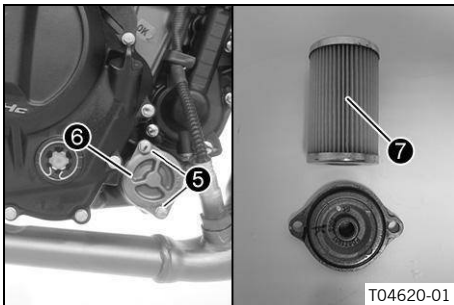

- Remove screws **5**. Take off oil filter cover **6** with the O-ring.
- Pull oil filter **7** out of the oil filter housing.
- Allow the engine oil to drain completely.
- Thoroughly clean the parts and the sealing surface.

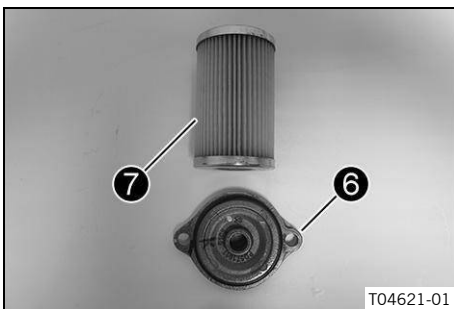

- Insert oil filter **7**.
- Oil the O-ring of the oil filter cover. Mount oil filter cover **6**.
- Mount and tighten screws **5**.

Screw, oil filter cover	
M6	11 Nm (8.1 ft·lb _r)

i Note
Too little engine oil or poor-quality engine oil will result in premature wear of the engine.

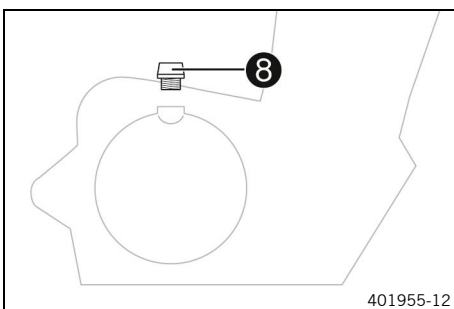

- Remove filler plug **8** with the O-ring, and fill up with engine oil.

engine oil	
engine oil (SAE 15W/50) 📖 (p. 129) fully synthetic	1.2 l (0.32 liq. gal _{US})

- Mount and tighten the oil plug together with the O-ring.



DANGER

Danger of poisoning Exhaust gases are toxic and inhaling them may result in unconsciousness and death.

- Always ensure that there is sufficient ventilation when running the engine.
- Use suitable exhaust extraction when starting or running the engine in an enclosed space.

- Start the engine and check it for leaks.

Reworking

- Check the engine oil level. (p. 102)

18.3 Adding engine oil



Note

Too little engine oil or poor-quality engine oil will result in premature wear of the engine.

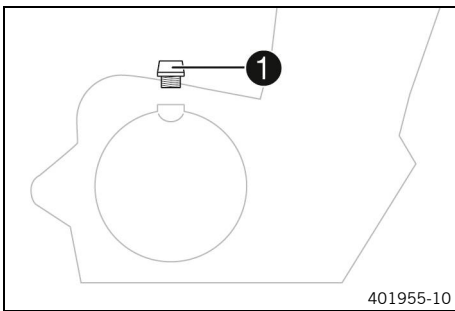

Main work

- Remove filler plug **1** with the O-ring, and fill up with engine oil.

engine oil (SAE 15W/50) (p. 129)
fully synthetic



Note

In order to achieve optimal engine oil performance, it is not advisable to mix different engine oils.

KTM recommends changing the engine oil if necessary.

- Mount and tighten the oil plug together with the O-ring.



DANGER

Danger of poisoning Exhaust gases are toxic and inhaling them may result in unconsciousness and death.

- Always ensure that there is sufficient ventilation when running the engine.
- Use suitable exhaust extraction when starting or running the engine in an enclosed space.

- Start the engine and check it for leaks.

Reworking

- Check the engine oil level. (p. 102)

19.1 Cleaning the motorcycle



NOTE

Material damage Components can be damaged or destroyed if a high-pressure cleaner is used incorrectly. The high pressure forces water into the electrical components, socket connectors, clutch cables, and bearings, etc.

Too high a pressure can cause malfunctions and destroy components.

- Do not direct the water jet directly on to electrical components, socket connectors, clutch cables, or bearings.
- Maintain a minimum distance between the nozzle of the high-pressure cleaner and the component.

Minimum distance	60 cm (23.6 in)
------------------	--------------------



NOTE

Environmental hazard Hazardous substances cause environmental damage.

- Dispose of oils, grease, filters, fuel, cleaning agents, brake fluid, etc. correctly and in accordance with the applicable regulations.



Note

Clean the motorcycle regularly to maintain its value and appearance over a long period. Avoid direct sunshine when cleaning the motorcycle.

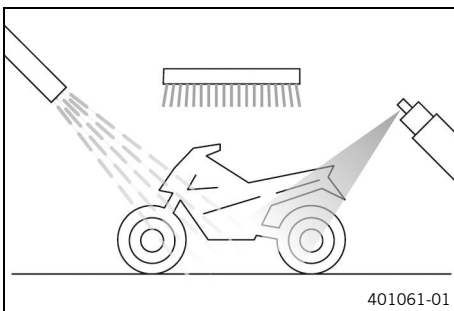

- Seal the exhaust system to prevent water from entering into it.
- Remove loose dirt first with a soft jet of water.
- Spray the heavily soiled parts with a standard commercial motorcycle cleaner and clean using a brush.

Never apply motorcycle cleaner to a dry motorcycle; always rinse the vehicle with water first.

Environmentally neutral universal cleaning agent
 (p. 134)



Note

Use warm water containing standard motorcycle cleaner and a soft sponge.

Clean the motorcycle with cold water if it has been used on salted roads. Warm water enhances the corrosive effects of salt.

- After rinsing the motorcycle with a gentle spray of water, allow it to dry thoroughly.
- Remove the cover from the exhaust system.



WARNING

Danger of accidents Moisture and dirt impair the brake system.

- Brake carefully several times to dry out and remove dirt from the brake pads and the brake discs.

- After cleaning, ride the vehicle a short distance until the engine warms up.

Note

The heat produced causes water to evaporate at inaccessible locations in the engine and on the brake system.

- Push back the sleeves of the handlebar controls to allow any water that has penetrated to evaporate.
- After the motorcycle has cooled off, lubricate all moving parts and pivot points.
- Clean the chain.  (p. 66)



WARNING

Danger of accidents Oil, grease or wax on the brake discs reduces the brake action.

- Always keep the brake discs free of oil, fat and wax.
- Clean the brake discs with brake cleaner when necessary.

- Treat bare metal (except for brake discs and the exhaust system) with an anticorrosive.

Preserving materials  (p. 134)

- Treat all painted parts with a mild paint care product.

Do not polish parts that were matte when delivered as this would strongly impair the material quality.

Shine spray with beading effect  (p. 134)

- Treat all plastic parts and powder-coated parts with a mild cleaning and care product.

Cleaning agents for plastics, glass, lacquers, metals, windshields and visors  (p. 134)

- Lubricate the ignition and steering lock.

Universal oil spray  (p. 129)

19.2 Checks and maintenance steps for winter operation



WARNING

Danger of accidents Salt on the roads impairs the brake system.

- Brake carefully several times to remove salt from the brake linings and the brake discs.



WARNING

Danger of accidents Oil, grease or wax on the brake discs reduces the brake action.

- Always keep the brake discs free of oil, fat and wax.
- Clean the brake discs with brake cleaner when necessary.

i Note

If you use the motorcycle in winter, salt can be expected on the roads. You should therefore take precautions against aggressive road salt.

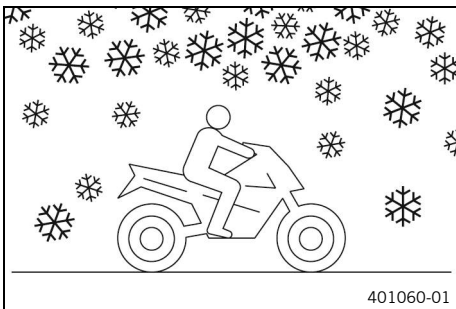

- Clean the motorcycle. 📖 (p. 105)
- Clean brake system.

After **EVERY** trip on salted roads, thoroughly clean the brake calipers and brake linings, after they have cooled down and without removing them, with cold water and dry them carefully.

After riding on salted roads, thoroughly clean the vehicle with cold water and dry it well.

i Note

Warm water enhances the corrosive effects of salt.

- Treat the engine, swingarm, and all other bare or zinc-plated parts (except the brake discs) with a wax-based anticorrosive.

Corrosion inhibitor must not come in contact with the brake discs as this would greatly reduce the braking force.

- Clean the chain. 📖 (p. 66)



20.1 Storage

i Note

If the vehicle will not be ridden for an extended period, additional steps are recommended. Before storing the motorcycle, check all parts for function and wear. If service, repairs, or replacements are necessary, you should do this during the storage period (less overload of the authorized partner). This allows you to avoid long waiting periods when the next season starts.

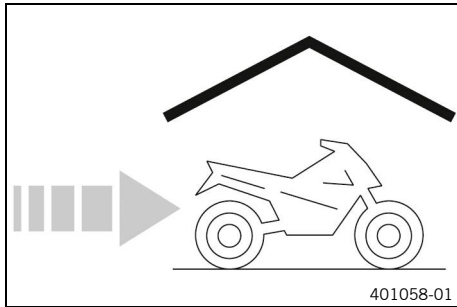

- When refueling for the last time before taking the motorcycle out of service, add fuel additive.









Fuel additive  (p. 128)
--

- Refuel.  (p. 58)



Tip

Fill the fuel tank completely as specified, using fuel with the lowest possible ethanol content.

- Clean the motorcycle.  (p. 105)
- Change the engine oil and the oil filter, clean the oil screens.   (p. 102)
- Check the frost protection and coolant level.  (p. 93)
- Check the tire pressure.  (p. 82)
- Remove the 12 V battery.   (p. 83)
- Charge the 12 V battery.   (p. 84)



Storage temperature of the 12 V battery without direct sunlight	0 °C ... 35 °C (32.0 °F ... 95.0 °F)
---	---

- Store the vehicle in a dry location that is not subject to large fluctuations in temperature.



Note

KTM recommends jacking up the motorcycle.

- Raise the motorcycle with the rear lifting gear.  (p. 62)
- Lift the motorcycle with the front lifting gear.  (p. 62)

Cover the motorcycle with a tarp or cover that is permeable to air.

Do not use non-porous materials because they prevent humidity from escaping and thus cause corrosion.



Note

Avoid running the engine of a motorcycle in storage for a short time only. Since the engine cannot warm up properly, the water vapor produced during combustion condenses and causes valves and the exhaust system to rust.



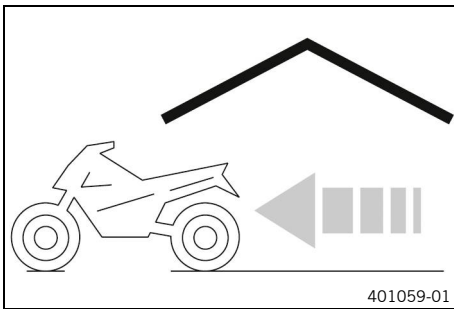



















20.2 Preparing for use after storage



















- Take the motorcycle off the front lifting gear. 📖 (p. 63)
- Remove the rear of the motorcycle from the lifting gear. 📖 (p. 62)
- Install the 12 V battery. 🔧 📖 (p. 84)
- Set time and date. 📖 (p. 44)
- Perform checks and maintenance measures when preparing for use. 📖 (p. 50)
- Take a test ride.



21.1 Troubleshooting

Cause	Finding	Remedy
The engine does not turn over when the start button is actuated	Operating error 12 V battery discharged Fuse 1 , 3 or 4 is blown No ground connection present on the starter motor	<ul style="list-style-type: none"> – Carry out the starting procedure.  (p. 50) – Charge the 12 V battery.   (p. 84) – Change the fuses of individual electrical power consumers.  (p. 89) – Check the ground connection.
The engine only turns over if the clutch lever is pulled	The vehicle is in gear The vehicle is in gear and the side stand is folded out	<ul style="list-style-type: none"> – Shift the transmission into the neutral position. – Shift the transmission into the neutral position.
The engine turns but does not start	Operating error Quick-lock coupling not joined Malfunction in the electronic fuel injection	<ul style="list-style-type: none"> – Carry out the starting procedure.  (p. 50) – Join quick-lock couplings. – Read out the fault memory using the diagnostics tool. 
Engine has too little power	Air filter is very dirty Fuel filter is very dirty Malfunction in the electronic fuel injection	<ul style="list-style-type: none"> – Change the air filter. – Check the fuel pressure.  – Read out the fault memory using the diagnostics tool. 
Engine overheats	Too little coolant in cooling system Radiator fins very dirty Foam formation in the cooling system Thermostat defective Fuse 5 blown Defect in radiator fan system	<ul style="list-style-type: none"> – Check the transmission and cooling system for leaks. – Check the coolant level.  (p. 95) – Clean the radiator fins. – Drain the coolant.   (p. 96) – Fill/bleed the cooling system.  –  (p. 96) – Check the thermostat.  – Change the fuses of individual electrical power consumers.  (p. 89) – Check the radiator fan system. 
Malfunction indicator lamp lights up red	Malfunction in the electronic fuel injection	<ul style="list-style-type: none"> – Read out the fault memory using the diagnostics tool. 
The engine dies during the trip	Lack of fuel Fuse 1 , 3 or 4 is blown	<ul style="list-style-type: none"> – Refuel.  (p. 58) – Change the fuses of individual electrical power consumers.  (p. 89)
The ABS warning light lights up	ABS fuse blown Large difference in wheel speeds of the front and rear wheels Malfunction in ABS	<ul style="list-style-type: none"> – Change the ABS fuses.  (p. 88) – Stop the vehicle, switch off the ignition, and start it again. – Read out the ABS fault memory using the diagnostic tool. 
High oil consumption	Engine vent hose bent The engine oil level is too high The engine oil is too thin (low viscosity)	<ul style="list-style-type: none"> – Route the vent hose without bends or change it if necessary. – Check the engine oil level.  (p. 102)

Cause	Finding	Remedy
		<ul style="list-style-type: none"> – Change the engine oil and the oil filter, clean the oil screens.   (p. 102)
Headlight and position light are not functioning	Fuse 6 blown	<ul style="list-style-type: none"> – Change the fuses of individual electrical power consumers.  (p. 89)
Turn signal, brake light, and horn are not functional	Fuse 6 blown	<ul style="list-style-type: none"> – Change the fuses of individual electrical power consumers.  (p. 89)
Time is not displayed or not correctly displayed	Fuse 2 blown Fuse 7 blown	<ul style="list-style-type: none"> – Change the fuses of individual electrical power consumers.  (p. 89) – Set time and date.  (p. 44) – Change the fuses of individual electrical power consumers.  (p. 89) – Set time and date.  (p. 44)
12 V battery discharged	Ignition was not switched off when vehicle was parked The 12-V battery is not being charged by the alternator	<ul style="list-style-type: none"> – Charge the 12 V battery.   (p. 84) – Check the charging voltage.  – Check the open-circuit current. 
The combination instrument shows nothing on the display	Fuse 2 blown Fuse 7 blown	<ul style="list-style-type: none"> – Change the fuses of individual electrical power consumers.  (p. 89) – Set time and date.  (p. 44) – Change the fuses of individual electrical power consumers.  (p. 89) – Set time and date.  (p. 44)
Speedometer in combination instrument is not functioning	Speedometer wiring harness is damaged or plug-in connector is oxidized	<ul style="list-style-type: none"> – Check the wiring harness and plug-in connector.



22.1 Engine

22.1.1 Technical data - engine

Design	1-cylinder 4-stroke engine, water-cooled
Displacement	249 cm ³ (15.19 in ³)
Hub	61.17 mm (2.4083 in)
Bore	72 mm (2.83 in)
Compression ratio	12.4:1
Control	SOHC, four valves controlled via rocker arm, chain drive
Valve diameter, intake	29 mm (1.14 in)
Valve diameter, exhaust	24 mm (0.94 in)
Valve clearance, intake, cold	0.08 mm ... 0.12 mm (0.0031 in ... 0.0047 in)
Valve clearance, exhaust, cold	0.13 mm ... 0.17 mm (0.0051 in ... 0.0067 in)
Crankshaft bearing	Slide bearing
big (bottom) end bearing	Slide bearing
Piston	Forged aluminum
Piston rings	1 compression ring, 1 tapered compression piston ring, 1 oil scraper ring
Engine lubrication	Pressure circulation lubrication
Primary transmission	27:76
Clutch	Clutch in oil bath/mechanically activated
Transmission	6-gear transmission
Gear ratios	
1st gear	11:33
2nd gear	15:29
3rd gear	18:26
4th gear	21:24
5th gear	23:22
6th gear	24:21
Mixture preparation	Electronic fuel injection
Ignition system	Contactless controlled fully electronic ignition with digital ignition adjustment
Alternator	<ul style="list-style-type: none"> • 12 V • 230 W (0.308 hp)
Spark plug	Champion REK6ZMC
Plug gap of spark plug	1 mm (0.04 in)

Cooling	Liquid cooling, permanent circulation of coolant by water pump
idle speed	1,550 rpm ... 1,650 rpm (25.83 Hz ... 27.50 Hz)
Starting aid	Starter motor

22.1.2 Capacities - engine

engine oil	
engine oil (SAE 15W/50)  (p. 129) fully synthetic	1.2 l (0.32 liq. gal _{US})
Coolant	
Coolant  (p. 130) Antifreeze protection to at least: -25 °C (-13.0 °F)	1.2 l (0.32 liq. gal _{US})

22.2 Chassis

22.2.1 Technical data - chassis

Frame	Lattice frame of steel tubes, powder-coated
Fork	WP suspension
Shock absorber	WP suspension
Suspension travel:	
front	150 mm (5.91 in)
rear	150 mm (5.91 in)
Brake system	
front	Disc brake with 4 piston brake caliper
rear	Disc brake with single-pot brake caliper, floating
Brake discs - diameter	
front	320 mm (12.60 in)
rear	240 mm (9.45 in)
Brake disc wear limit	
front	4.5 mm (0.177 in)
rear	4.5 mm (0.177 in)
Tire pressure when solo	
front	2.0 bar (29.0 psi)
rear	2.2 bar (31.9 psi)
Tire pressure with passenger / full payload	

22 Technical specifications

front	2.0 bar (29.0 psi)
rear	2.2 bar (31.9 psi)
Final drive	14:43 Note Modifications to the transmission ratio are not permitted and can lead to malfunctions.
Chain	5/8 x 1/4" (520) X-ring
Steering head angle	66° (1.15 rad)
Wheelbase	1,370 mm (53.94 in)
Seat Height unloaded	800 mm (31.50 in)
Ground clearance unloaded	185 mm (7.28 in)
Dry weight	165 kg (363.8 lb)
Maximum permissible front axle load	127 kg (280.0 lb)
Maximum permissible rear axle load	228 kg (502.7 lb)
Maximum permissible total weight	355 kg (782.6 lb)

22.2.2 Technical data - tires

Tire front	Rear tire
110/70 R 17 M/C 54H TL Metzeler Sportec M5 Interact	150/60 R 17 M/C 66H TL Metzeler Sportec M5 Interact
The tires specified represent one of the possible series production tires. For alternative manufacturers, if any, contact an authorized manufacturer or qualified tire dealership. If local road approval regulations apply, these and the respective technical specifications must be observed.	

22.2.3 fuel

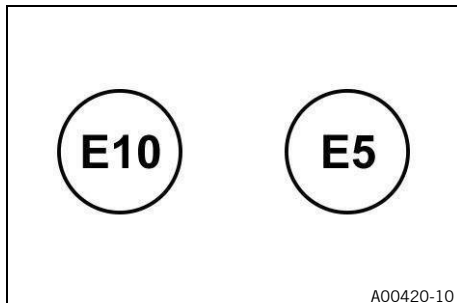

Please observe the labels on EU fuel pumps.

22.2.4 Capacities - vehicle

Total fuel tank capacity, approx.	
Super unleaded (ROZ 95)  (p. 128)	15 l (4.0 liq. gal _{US})

22.3 Electrics

22.3.1 Battery

12 V battery	ETZ-9-BS	Battery voltage: 12 V Nominal capacity: 8 Ah Maintenance-free
--------------	----------	---

22.3.2 Fuses

12 V battery	ETZ-9-BS	Battery voltage: 12 V Nominal capacity: 8 Ah Maintenance-free
Fuse	75011088010	10 A
Fuse	75011088015	15 A
Fuse	75011088020	20 A
Fuse	90111088025	25 A
Fuse	75011088030	30 A

22.3.3 Lamps

Headlight	LED
Low beam/high beam	LED
Daytime running light/position light	LED
Dashboard illumination and indicator lights	LED
Turn signal	LED
Tail light	LED
Brake light	LED
License plate lighting	LED

22.4 Fork

22.4.1 Technical data - fork

Fork part number	96201001000 / 96201002000
Fork	WP suspension
Fork length	747.5 mm (29.429 in)

22.4.2 Fork oil capacity

Fork oil per fork leg	
Fork oil (SAE 5)  (p. 129)	460 ±5 ml (15.55 ±0.17 fl. oz _{US})

22.5 Shock absorber

22.5.1 Technical data - shock absorber

Shock absorber part number	96201010033
Shock absorber	WP suspension
Preload	
Standard	3 clicks

22.6 Tightening torque

22.6.1 Engine tightening torques

Screw, crankshaft position sensor	M5×0.8	5.5 Nm (4.06 ft·lb _f) Loctite® 243
Oil spray jet	M5×0.8	5.5 Nm (4.06 ft·lb _f) Loctite® 243
Oil nozzle	M5×0.8	5.5 Nm (4.06 ft·lb _f) Loctite® 243
Screw, shift shaft sensor	M5×0.8	6 Nm (4.4 ft·lb _f)
Stator screw	M5×0.8	7.5 Nm (5.53 ft·lb _f) Loctite® 243
Screw, retaining bracket, stator cable	M5×0.8	5.5 Nm (4.06 ft·lb _f) Loctite® 243
Screw, gear position sensor	M5	5.5 Nm (4.06 ft·lb _f) Loctite® 243
Oil spray jet, crank	M5×0.8	3.5 Nm (2.58 ft·lb _f) Loctite® 243
Screw, oil filter cover	M6	11 Nm (8.1 ft·lb _f)
Screw plug, water pump drain hole	M6	11 Nm (8.1 ft·lb _f) Loctite® 243

Nut, water pump impeller	M6	8 Nm (5.9 ft·lb _r) Loctite® 243
TDC locking screw, balancer shaft	M6	11 Nm (8.1 ft·lb _r) Loctite® 243
Screw, retaining bracket	M6	11 Nm (8.1 ft·lb _r) Loctite® 243
Oil nozzle, clutch	M6×1	4 Nm (3.0 ft·lb _r) Loctite® 243
Screw, thermostat	M6	11 Nm (8.1 ft·lb _r)
Screw, release for timing chain tensioner	M6	8 Nm (5.9 ft·lb _r)
Chain shaft screw, cylinder head	M6	11 Nm (8.1 ft·lb _r)
Screw, inlet sleeve	MM6	9 Nm (6.6 ft·lb _r)
Screw, clutch cover	M6	11 Nm (8.1 ft·lb _r)
Screw, camshaft bearing bridge	M6	11 Nm (8.1 ft·lb _r)
Screw, valve cover	M6	11 Nm (8.1 ft·lb _r)
Screw, front sprocket plate	M6	5.5 Nm (4.06 ft·lb _r) Loctite® 243
Screw, engine case	M6×35	11 Nm (8.1 ft·lb _r) Loctite® 243
Screw, engine case	M6×70	11 Nm (8.1 ft·lb _r) Loctite® 243
Screw, engine case	M6×85	11 Nm (8.1 ft·lb _r) Loctite® 243
Screw, freewheel gear retaining bracket	M6	11 Nm (8.1 ft·lb _r) Loctite® 243
Screw, bearing retainer	M6	11 Nm (8.1 ft·lb _r) Loctite® 243
Screw, ignition cover	M6	11 Nm (8.1 ft·lb _r)

22 Technical specifications

Screw, timing chain tensioning rail	M6	11 Nm (8.1 ft·lb _f) Loctite® 243	
Shift star screw	M6	11 Nm (8.1 ft·lb _f) Loctite® 243	
Screw, engine vent plate	M6	11 Nm (8.1 ft·lb _f) Loctite® 243	
Detent arm screw	M6	11 Nm (8.1 ft·lb _f) Loctite® 243	
Screw, water pump cover	M6	11 Nm (8.1 ft·lb _f)	
Screw, camshaft gear wheel	M6	11 Nm (8.1 ft·lb _f) Loctite® 243	
Screw, timing chain tensioner	M6	11 Nm (8.1 ft·lb _f) Loctite® 243	
Screw, oil pump	M6	11 Nm (8.1 ft·lb _f) Loctite® 243	
Screw, starter motor	M6	11 Nm (8.1 ft·lb _f)	
Screw, front sprocket	M6	11 Nm (8.1 ft·lb _f)	
Screw, main shaft retaining bracket	M6	11 Nm (8.1 ft·lb _f)	
TDC locking screw, crankshaft	M8	15.5 Nm (11.43 ft·lb _f) Loctite® 243	
Stud, exhaust flange	M8	21 Nm (15.5 ft·lb _f)	
Exhaust flange nut	M8	21 Nm (15.5 ft·lb _f)	
Screw, spring thrust bearing of the shift shaft	M8×1.25	20.5 Nm (15.12 ft·lb _f) Loctite® 243	
Screw, conrod bearing	M9×1 Long-life grease	1.	17.7 Nm (13.05 ft·lb _f)
		2.	60° (1.05 rad)
Coolant temperature sensor	M10×1.5	13 Nm (9.6 ft·lb _f)	
Screw, cylinder head	M10×1.25	43 Nm (31.7 ft·lb _f) Long-life grease	

Oil pressure sensor	M10×1	12.5 Nm (9.22 ft·lb _f)
Spark plug	M10×1	11 Nm (8.1 ft·lb _f)
Screw, rotor	M12×1.5	119 Nm (87.8 ft·lb _f)
Nut, inner clutch hub	M14LH×1	66 Nm (48.7 ft·lb _f) Loctite® 243
Screw plug, cam lever shaft	M14×1	9.5 Nm (7.01 ft·lb _f) Loctite® 243
Nut, primary gear wheel/timing chain sprocket	M16×1.5	109 Nm (80.4 ft·lb _f) Loctite® 243
Oil screen screw plug, small	M17×1.5	11 Nm (8.1 ft·lb _f)
Screw plug, alternator cover TDC	M18×1.5	9 Nm (6.6 ft·lb _f)
Oil screen screw plug, large	M24×1.5	12.5 Nm (9.22 ft·lb _f)
Screw plug, alternator cover	M24×1.5	11 Nm (8.1 ft·lb _f)

22.6.2 Chassis tightening torques

Remaining screws on chassis	M4	4 Nm (3.0 ft·lb _f)
Screw, side stand sensor	M5	5 Nm (3.7 ft·lb _f) Loctite® 243
Screw, fuel tank lid	M5	5 Nm (3.7 ft·lb _f)
Remaining screws on chassis	M5	5 Nm (3.7 ft·lb _f)
Remaining nuts on chassis	M5	5 Nm (3.7 ft·lb _f)
Screw, tail light	M5	5 Nm (3.7 ft·lb _f)
Screw, chain guard	M5	7 Nm (5.2 ft·lb _f) Loctite® 243
Screw, outer clutch cable guide	M5	5 Nm (3.7 ft·lb _f) Loctite® 243
Screw, combination instrument	M5	4 Nm (3.0 ft·lb _f)

22 Technical specifications

Screw, combination instrument holder cover	M5	5 Nm (3.7 ft·lb _f)
Screw, fuel pump	M6	9 Nm (6.6 ft·lb _f)
Screw, magnetic holder on side stand	M6	5 Nm (3.7 ft·lb _f) Loctite® 243
Screw, ABS hose clamp	M6	7 Nm (5.2 ft·lb _f)
Screw, side stand sensor cable holder	M6	9 Nm (6.6 ft·lb _f) Loctite® 243
Screw, wheel speed sensor holder	M6	9 Nm (6.6 ft·lb _f)
Screw, bell crank shift lever	M6	11 Nm (8.1 ft·lb _f) Loctite® 243
Screw, chain guard	M6	9 Nm (6.6 ft·lb _f)
Screw, brake cylinder	M6	7 Nm (5.2 ft·lb _f) Loctite® 243
Screw, rear splash protector	M6	9 Nm (6.6 ft·lb _f)
Screw, chain slider guard	M6	9 Nm (6.6 ft·lb _f)
Screw, brake fluid reservoir for rear brake	M6	7 Nm (5.2 ft·lb _f) Loctite® 243
Screw, radiator holder	M6	6 Nm (4.4 ft·lb _f)
Screw, ignition coil	M6	8 Nm (5.9 ft·lb _f)
Screw, tilt sensor	M6	6 Nm (4.4 ft·lb _f) Loctite® 243
Screw, front fender	M6	6 Nm (4.4 ft·lb _f)
Screw, fuel tank	M6	11 Nm (8.1 ft·lb _f)
Screw, front seat fixing	M6	9 Nm (6.6 ft·lb _f)
Screw, license plate holder	M6	10 Nm (7.4 ft·lb _f) Loctite® 243
Screw, lower rear panel	M6	5 Nm (3.7 ft·lb _f)

Remaining screws on chassis	M6	9 Nm (6.6 ft·lb _f)
Remaining nuts on chassis	M6	15 Nm (11.1 ft·lb _f)
Screw, top main silencer	M6	11 Nm (8.1 ft·lb _f)
Screw, chain guard on link fork	M6	9 Nm (6.6 ft·lb _f)
Screw, ABS module	M6	7 Nm (5.2 ft·lb _f)
Screw, rear wheel speed sensor	M6	8 Nm (5.9 ft·lb _f) Loctite® 243
Screw, silent block	M6	7 Nm (5.2 ft·lb _f)
Screw, lower rear panel	M6	5 Nm (3.7 ft·lb _f)
Screw, air filter box	M6	7 Nm (5.2 ft·lb _f)
Screw, compensating tank cap lock, rear brake	M6	7 Nm (5.2 ft·lb _f)
Screw, damper block	M6	7 Nm (5.2 ft·lb _f)
Screw, ABS module retaining bracket on frame	M6	7 Nm (5.2 ft·lb _f)
Screw, ignition lock (tamper-proof screw)	M6	Tighten until the head tears off.
Fuel tank cover screw	M6	6 Nm (4.4 ft·lb _f)
Screw, radiator shield	M6	8 Nm (5.9 ft·lb _f)
Screw, brake hose clamp	M6	7 Nm (5.2 ft·lb _f)
Screw, front sprocket cover	M6	11 Nm (8.1 ft·lb _f)
Screw, headlight	M6	6 Nm (4.4 ft·lb _f)
Screw, bracket of fuel vapor valve	M6	9 Nm (6.6 ft·lb _f)
Screw, protective plate	M6	7 Nm (5.2 ft·lb _f)
Screw, combination instrument holder clamp	M6	2 Nm (1.5 ft·lb _f)
Screw, battery terminal	M6	4.5 Nm (3.32 ft·lb _f)
Screw, rear seat fixing	M8	21 Nm (15.5 ft·lb _f)

22 Technical specifications

Screw, foot brake lever	M8	16 Nm (11.8 ft·lb _f) Loctite® 243
Screw, bottom triple clamp	M8	12 Nm (8.9 ft·lb _f)
Screw, top triple clamp	M8	17 Nm (12.5 ft·lb _f)
Screw, fork shoe	M8	15 Nm (11.1 ft·lb _f)
Screw, front brake disc	M8	30 Nm (22.1 ft·lb _f) Loctite® 243
Screw, rear brake disc	M8	21 Nm (15.5 ft·lb _f) Loctite® 243
Screw, handlebar clamp	M8	20 Nm (14.8 ft·lb _f)
Screw, front brake caliper	M8×1	29 Nm (21.4 ft·lb _f) Loctite® 243
Nut, rear sprocket	M8	34 Nm (25.1 ft·lb _f)
Screw, horn	M8	16 Nm (11.8 ft·lb _f)
Passenger footrest support screw	M8	21 Nm (15.5 ft·lb _f) Loctite® 243
Screw, supporting strap	M8	21 Nm (15.5 ft·lb _f)
Remaining screws on chassis	M8	25 Nm (18.4 ft·lb _f)
Remaining nuts on chassis	M8	30 Nm (22.1 ft·lb _f)
Screw, bottom main silencer	M8	21 Nm (15.5 ft·lb _f)
Screw, front seat fixing	M8	25 Nm (18.4 ft·lb _f)
Screw, seat support plate	M8	18 Nm (13.3 ft·lb _f)
Screw, engine bearer on frame	M8	26 Nm (19.2 ft·lb _f)
Screw, crash bar on engine bearer	M8	19 Nm (14.0 ft·lb _f)
Stud, rear sprocket	M10×1.25	50 Nm (36.9 ft·lb _f)
Screw, engine bearer on engine	M10	44 Nm (32.5 ft·lb _f)

Fitting, handlebar support	M10	21 Nm (15.5 ft·lb _f)	
Fitting, side stand	M10	35 Nm (25.8 ft·lb _f) Loctite® 243	
Top shock absorber screw	M10×1.25	50 Nm (36.9 ft·lb _f) Loctite® 243	
Nut, rear mirror	M10	23 Nm (17.0 ft·lb _f)	
Remaining screws on chassis	M10	46 Nm (33.9 ft·lb _f)	
Remaining nuts on chassis	M10	50 Nm (36.9 ft·lb _f)	
Fitting, bottom shock absorber	M10×1.25	50 Nm (36.9 ft·lb _f) Loctite® 243	
Banjo bolt, brake line	M10	24 Nm (17.7 ft·lb _f)	
Screw, engine brace	M10	49 Nm (36.1 ft·lb _f) Loctite® 243	
Screw, footpeg bracket, front	M10×1.25	47 Nm (34.7 ft·lb _f) Loctite® 243	
Screw, subframe, bottom	M10	43 Nm (31.7 ft·lb _f) Loctite® 620	
Screw, subframe, top	M10	43 Nm (31.7 ft·lb _f)	
Nut, swingarm pivot	M14	100 Nm (73.8 ft·lb _f)	
Nut, wheel spindle, rear	M16	100 Nm (73.8 ft·lb _f)	
Screw, top steering head	M22	74 Nm (54.6 ft·lb _f)	
Adjusting ring, fork bearing	M22	9 Nm (6.6 ft·lb _f)	
Screw, wheel spindle, front	M24	45 Nm (33.2 ft·lb _f)	
Nut, steering head	M30	1.	45 Nm (33.2 ft·lb _f)
		2.	Loosen by 2 turns
		3.	5 Nm (3.7 ft·lb _f)

23.1 Declarations of conformity

i Note

The functional and equipment scope is model-dependent and may not include all wireless systems and application areas referred to.

JNS Instruments Ltd. hereby declares that the **320T1100** wireless system conforms with the relevant guidelines. The full text of the Declaration of Conformity is available at the following Internet address.
 Certification website: <https://www.ktm.com/320T1100>

23.2 Country-specific declarations of conformity

<p>"En el Perú, este equipo diseñado para la banda de 902-928 MHz, debe ser configurado para operar sólo en la banda 915-928 MHz con una PIRE de hasta 1W (30 dBm) y sujeto a las Condiciones de Operación que establezca el MTC."</p> <p>"En el Perú, este equipo diseñado para la banda de 902-928 MHz, debe ser configurado para operar sólo en la banda 916-928 MHz con una PIRE de hasta 4W (36 dBm) y sujeto a las Condiciones de Operación que establezca el MTC."</p> <p>"En el Perú, este equipo diseñado para la banda de 5925-7125 MHz, debe ser configurado para operar sólo en la banda 915-928 MHz con una PIRE de hasta 1W (30 dBm) y sujeto a las Condiciones de Operación que establezca el MTC."</p>	
<p>TRCSL APPROVED Ref No. TRC/SM/TA/0041/23-9018</p>	<p>AGREE PAR L'ANRT MAROC Numéro d'agrément: MR00039589ANRT2023 Date d'agrément: 08/08/2023</p>

A01740-01

24.1 Recycling



I02045-10

Further information is available at the following website.
Recycling information website: <https://www.quefairedemesdechets.fr>

A Technical terms

ABS	Anti-lock braking system	Safety system that prevents locking of the wheels when riding straight ahead without the influence of lateral forces.
ATIR	Automatic Turn Indicator Reset	Software, which automatically switches the turn signal off according to a time or travel distance counter.
	KTMconnect	System for remote communication with suitable cell phones and communication systems for telephony and audio
OBD	On-board diagnosis	Vehicle system that monitors the specified parameters of the vehicle electronics.
	QUICKSHIFTER+	Engine electronics function for shifting up and down without clutch actuation

B Fuels

Super unleaded

Standards

- ROZ 95 → DIN EN 228

Fuel additive

Recommended supplier

MOTOREX®

- **FUEL STABILIZER**

C Operating supplies

Street chain spray

Recommended supplier

MOTOREX®

- CHAINLUBE ROAD STRONG

Fork oil

Recommended supplier

MOTOREX®

- RACING FORK OIL

Standards

- SAE 5 → SAE

Universal oil spray

Recommended supplier

MOTOREX®

- JOKER 440 SYNTHETIC

Long-life grease

Recommended supplier

MOTOREX®

- Bike Grease 2000

engine oil

Recommended supplier

MOTOREX®

- V-SYNT 4T

Standards

→ JASO T903 MA2

- SAE 15W/50 → SAE

Properties

- fully synthetic

Brake fluid DOT 5.1

Recommended supplier

MOTOREX®

- BRAKE FLUID DOT 5.1

Standards

→ DOT

Coolant

Recommended supplier

MOTOREX®

- COOLANT M3.0

Properties

- | | |
|-------------------------------------|----------------------|
| • Antifreeze protection to at least | -25 °C
(-13.0 °F) |
|-------------------------------------|----------------------|

D Electrics**Low beam/high beam (LED)****Product code**

- LED

12 V battery (ETZ-9-BS)**Product code**

- ETZ-9-BS

Properties

- | | |
|--------------------|------|
| • Battery voltage | 12 V |
| • Nominal capacity | 8 Ah |
| • Maintenance-free | |

Turn signal (LED)**Product code**

- LED

Brake light (LED)**Product code**

- LED

License plate lighting (LED)**Product code**

- LED

Dashboard illumination and indicator lights (LED)**Product code**

- LED

Tail light (LED)**Product code**

- LED

Headlight (LED)

Product code

- LED

Fuse (75011088010)

Product code

- 75011088010

Properties

- 10 A

Fuse (75011088015)

Product code

- 75011088015

Properties

- 15 A

Fuse (75011088020)

Product code

- 75011088020

Properties

- 20 A

Fuse (90111088025)

Product code

- 90111088025

Properties

- 25 A

Fuse (75011088030)

Product code

- 75011088030

Properties

- 30 A

Daytime running light/position light (LED)

Product code

- LED
-

E Cleaning agents

Shine spray with beading effect

Recommended supplier

MOTOREX®

- MOTO SHINE MS1

Chain cleaner

Recommended supplier

MOTOREX®

- CHAIN CLEAN

Preserving materials

Recommended supplier

MOTOREX®

- MOTO PROTECT

Cleaning agents for plastics, glass, lacquers, metals, windshields and visors

Recommended supplier

MOTOREX®

- QUICK CLEANER

Environmentally neutral universal cleaning agent

Recommended supplier

MOTOREX®

- MOTO CLEAN UNIVERSAL

F Icons

F.1 Symbol colors



F.1.1 Red symbols

Red symbols indicate a fault status that requires immediate intervention.

	The oil pressure warning light lights up red
---	--



F.1.2 Yellow and orange symbols

Yellow and orange symbols indicate a malfunction status that requires prompt intervention. Active driving aids are also represented by yellow or orange symbols.

	ABS warning light lights up yellow
	The malfunction indicator light lights up yellow
	General warning light lights up yellow

F.1.3 Green and blue symbols

Green and blue symbols convey information.

	The turn signal indicator light flashes green with a steady blinking interval
	The high beam indicator lamp lights up blue
	The idle indicator lamp lights up green

1	
12 V battery	
charging	84
installation	84
removing	83
A	
ABS	70
ABS fuses	
changing	88
ACC1	
front	92
rear	92
ACC2	
front	92
rear	92
Accessories	11
Antifreeze	
checking	93
Anti-lock braking system	70
Auxiliary substances	11
B	
Brake discs	
checking	71
Brake fluid	
adding front brake	72
adding to rear brake	74
Brake fluid level	
checking on front brake	72
checking on rear brake	74
Brake lining retainers	
checking on front brake	73
checking on rear brake	76
Brake linings (brake pads)	
checking on front brake	73
checking on rear brake	76
Brake pedal	23
Brakes	55
Braking	55
Breakdown	
towing	57
C	
Chain	
checking	68
cleaning	66
dirt, checking for	66
Chain tension	
adjusting	67
checking	67
Clothing	9
Clutch lever	16
Combination instrument	
ABS	33
ABS display	30
activation and testing	25
Bike info	34
Bluetooth	39
connectivity	39
coolant temperature indicator	30
Delete All Rounds	38
Display	28
Extra Functions	46
favorites	38
indicator lamps	26
Lap timer	37
navigation	35
Overview	25
Quick selector 1	38
Quick selector 2	39
Settings	38
shift light	29
start/stop navigation (optional)	36
trip	34
volume	36
Warning	34
Combination switch	16
Overview	16
Conditions of use	
use in difficult conditions	11
Coolant	
changing	98
draining	96
Coolant level	
checking	93, 95
Cooling system	93
filling/bleeding	96
Customer service	11
D	
Dashboard	
Audio	37
Call display	32
Date format	44
Distance	45
Favorites display	31
fuel level display	31

Fuel Cons	45	Fuel tank cap	
headset pairing	41	closing	21
Navigation display (optional)	32	opening	20
pairing a phone	40	Fuse	
Quick Selector 1 display	31	of the individual electrical power consumers,	
Quick Selector 2 display	31	changing	89
QUICKSHIFTER+ (optional)	42	G	
Remote Control Mode (optional)	32	Gear shift lever	23
speed	28	adjusting	61
speed display	29	Grab handle	22
Temperature	45	H	
time	29	Handbrake lever	16
Trip 1	35	Hazard warning flasher	17
Trip 2	35	Hazard warning flasher switch	17
Type of audio device	42	Headlight setting	
Units	44	adjusting	91
warnings	26	checking	91
Date		Horn button	17
adjusting	44	I	
Declarations of conformity	124	Ignition lock	19
country-specific	124	Implied warranty	11
Defined use	10	Improper use	10
Diagnostic connector	92	indicator lamps	26
Difficult operating conditions	11	K	
E		Kill switch	18
Electric starter	19	L	
Engine		Light switch	18
running in	48	Loading the vehicle	48
Engine number	15	Luggage	48
engine oil		M	
adding	104	Main fuse	
changing	102	changing	86
Engine oil level		Manufacturer warranty	11
checking	102	Manufacturer's warranty	11
Engine sprocket		Motorcycle	
checking	68	cleaning	105
Environment	10	lifting gear at rear, raising with	62
F		raising the front with lifting gear	62
Figures	11	removing from the front lifting gear	63
Fork legs		removing the rear from the lifting gear	62
cleaning the dust boots	64	O	
Front rider's seat		Oil filter	
mounting	65	changing	102
removing	65	Oil screens	
Front wheel		cleaning	102
installation	77	On-board tool kit	22
removing	77		

Owner's manual	10	Steering lock	19
P		Stopping	56
Parking	56	Storage	108
Passenger footpegs	22	Storage compartment	
Passenger seat		USB socket	19
mounting	65	T	
removing	64	Tampering	8
Play in the clutch lever		Throttle grip	16
adjusting	101	Time	
checking	101	adjusting	44
Preparing for use		Tire condition	
after storage	109	checking	81
checks and maintenance measures when		Tire pressure	
preparing for use	50	checking	82
Notes on preparing for first use	47	towing	57
Protective clothing	9	Transport	57
Q		Turn signal switch	18
QUICKSHIFTER+	52	U	
R		USB socket	19
Rear hub damping rubbers		V	
checking	80	Vehicle identification number	15
Rear sprocket		View of the vehicle	
checking	68	front left	13
Rear wheel		rear right	14
installation	79	VIN	15
removing	78	W	
Recycling	125	Winter operation	
Refueling		checks and maintenance steps	106
fuel	58	Work rules	9
Resources	11		
Riding	52		
Starting off	51		
Roadside Assistance	12		
S			
Safe use	9		
Seat lock	22		
Service	11		
Shifting	52		
Shock absorber			
adjusting the spring preload	61		
Side stand	24		
spare parts	11		
Starting	50		
Steering			
locking	20		
unlocking	20		



3240320en

02/07/2026

