

SX-E 5

ITEM NO.: 3240378EN



Congratulations on your decision to purchase a KTM motorcycle. You are now the owner of a state-of-the-art sports vehicle that will continue to give you and your child pleasure for a long time if you maintain it properly.

We hope your child has many safe and enjoyable rides!

You can enter the serial numbers of your vehicle below to find the serial numbers more quickly if required:

<u>Vehicle identification number</u> 📖 (p. 17)	Stamp of the contractual partner
<u>Engine number</u> 📖 (p. 17)	

Read through this owner's manual carefully, always exercise caution when using the vehicle, and contact an authorized contractual partner if you have any questions.

This Owner's Manual serves as a technical instruction manual, explains important safety matters, and provides an overview of the main functions. This Owner's Manual is only intended for personal use. This Owner's Manual is not intended for commercial use.

The owner's manual contained the latest information for this model series at the time of publication. However, minor differences due to further developments in design cannot be ruled out completely.

All specifications contained herein are non-binding. KTM Sportmotorcycle GmbH specifically reserves the right to modify or delete technical specifications, prices, colors, forms, materials, services, designs, equipment, etc., without prior notice and without specifying reasons, to adapt these to local conditions, as well as to stop production of a particular model without prior notice. KTM accepts no liability for delivery options, differences from illustrations and descriptions, misprints, and other errors. The models portrayed partly contain special equipment that does not belong to the regular scope of supply.

© 2026 KTM Sportmotorcycle GmbH, Mattighofen Austria

All rights reserved. Figures: Mitterbauer / Visus Studios / KISKA / KTM

Written permission from the copyright owner is required before any duplication or reproduction.

ISO 9001

KTM applies quality assurance processes that lead to the highest possible product quality as defined in the ISO 9001 international quality management standard.



12 100 6061

Issuing institution:

TÜV SÜD Management Service GmbH

KTM Sportmotorcycle GmbH
Stallhofnerstraße 3
5230 Mattighofen, Austria

This document is valid for:

SX-E 5 (F3001627)



SX-E 5 US (F3075C27)



3240378en

19/05/2026

Table of contents

1	Means of representation.....	7	6.6	Brake pedal	20
1.1	Conventions.....	7	6.7	Plug-in stand	21
1.1.1	Icons	7	6.8	Diagnostic connector	21
1.1.2	Formatting	7	7	Multifunctional element	22
1.1.3	Abbreviations	7	7.1	Multifunctional element	22
2	Safety	8	7.2	Ride mode button	22
2.1	Safety instructions	8	7.3	Riding mode indicator	23
2.2	Warning against tampering with the machine	8	7.4	Malfunction indicator lamp	23
2.3	Safe use	8	7.5	Charging level indicator	24
2.4	Fall or accident	9	7.6	Power reduction	24
2.5	Protective clothing	9	8	Preparing for use	25
2.6	Work on vehicle, engine, and rechargeable lithium-ion battery	10	8.1	Notes on preparing for first use	25
2.7	Environment	10	9	Riding instructions	27
2.8	Owner's manual	11	9.1	Checks and maintenance measures when preparing for use	27
2.9	Fire hazard	11	9.2	Starting the vehicle	27
2.10	Use definition – intended use	11	9.3	Starting off	28
2.11	Improper use	12	9.4	Braking	28
3	Important notes	13	9.5	Recuperation	29
3.1	Manufacturer's warranty, implied warranty	13	9.6	Stop, park	29
3.2	Auxiliary material, operating material	13	9.7	Transportation	30
3.3	Spare parts, accessories	13	10	Service schedule	31
3.4	Service	13	10.1	Service schedule	31
3.5	Figures	13	11	Suspension setting	33
3.6	Customer service	13	11.1	Checking the basic chassis setting with the rider's weight	33
3.7	Voltage supply	14	11.2	Air suspension	33
3.8	Operation at low temperatures	14	11.3	Compression damping of the shock absorber	34
4	View of the vehicle	15	11.4	Adjusting the low-speed compression damping of the shock absorber	34
4.1	View of vehicle, front left (example)	15	11.5	Adjusting the high-speed compression damping of the shock absorber	34
4.2	View of vehicle, rear right (example)	16	11.6	Adjusting the rebound damping of the shock absorber	35
5	Serial number	17	11.7	Measuring the dimension of the unloaded rear wheel	36
5.1	Vehicle identification number	17	11.8	Checking the static sag of the shock absorber	36
5.2	Frame label	17	11.9	Checking the rider sag of the shock absorber	37
5.3	Engine number	17	11.10	Adjusting the preload for the shock absorber 	37
5.4	Fork part number	17	11.11	Adjusting the rider sag 	38
5.5	Shock absorber part number	18	11.12	Checking the basic setting of the fork	39
5.6	Battery identification number	18	11.13	Adjusting the fork air pressure	39
6	Controls	19			
6.1	Handbrake lever	19			
6.2	Throttle grip	19			
6.3	On/Off button	19			
6.4	Magnetic switch on handlebar	19			
6.5	Magnetic switch under the seat	20			





































11.14	Adjusting the rebound damping of the fork	40	13.29	Cleaning the chain	62
11.15	Handlebar position	41	13.30	Checking the chain tension	63
11.16	Adjusting the handlebar position 	41	13.31	Adjusting the chain tension	63
12	Seat height	42	13.32	Checking the chain, rear sprocket, front sprocket, and chain guide	64
12.1	Seat height adjustment options	42	13.33	Adjusting the chain guide 	66
12.2	Adjusting the seat height on the shock absorber 	42	13.34	Checking the frame 	66
12.3	Adjusting the seat height on the fork 	43	13.35	Checking the swingarm 	67
12.4	Adjusting the seat height on the frame 	44	13.36	Checking the hand grip	67
13	Service work on the chassis	47	14	Brake system	68
13.1	Raising the motorcycle with a lift stand	47	14.1	Checking the free travel of the hand brake lever	68
13.2	Removing the motorcycle from the lift stand	47	14.2	Adjusting the basic position of the hand brake lever	68
13.3	Bleeding the fork legs	47	14.3	Checking the brake discs	68
13.4	Cleaning the dust boots of the fork legs	48	14.4	Checking the brake fluid level for the front brake	69
13.5	Removing the fork protector	49	14.5	Adding brake fluid for the front brake 	70
13.6	Installing the fork protector	49	14.6	Checking that the brake pads of the front brake are secured	71
13.7	Removing the fork legs 	49	14.7	Changing the brake pads of the front brake 	72
13.8	Installing the fork legs 	50	14.8	Checking the free travel of the brake pedal	74
13.9	Removing the lower triple clamp 	51	14.9	Adjusting the free travel of the foot brake lever 	74
13.10	Installing the lower triple clamp 	52	14.10	Adjusting the basic position of the brake pedal 	75
13.11	Checking the steering head bearing play	54	14.11	Checking the brake fluid level for the rear brake	76
13.12	Adjusting the steering head bearing play 	55	14.12	Adding brake fluid for the rear brake 	77
13.13	Lubricating the steering head bearing 	56	14.13	Checking that the brake pads of the rear brake are secured	78
13.14	Removing the number plate	56	14.14	Changing the rear brake pads 	78
13.15	Mounting the number plate	56	15	Wheels, tires	81
13.16	Removing the front top fender	57	15.1	Removing the front wheel 	81
13.17	Installing the front top fender	57	15.2	Installing the front wheel 	81
13.18	Removing the shock absorber 	57	15.3	Removing the rear wheel 	82
13.19	Installing the shock absorber 	58	15.4	Installing the rear wheel 	83
13.20	Checking the rubber buffer and pivot points of the shock absorber	58	15.5	Checking the tire condition	84
13.21	Removing the seat	59	15.6	Checking the tire pressure	85
13.22	Mounting the seat	59	15.7	Checking the spoke tension	86
13.23	Removing the left side panel	59	16	LV traction battery, battery charger	87
13.24	Installing the left side panel	60	16.1	Overview of battery charger	87
13.25	Removing the right side panel	60	16.2	Positioning the battery charger	87
13.26	Installing the right side panel	61	16.3	Charging the LV traction battery	88
13.27	Securing the side panel	61			
13.28	Checking the chain for dirt	62			

Table of contents

17	Cooling	91	D	Icons.....	117
17.1	Cooling	91	D.1	Symbol colors	117
17.2	Checking the frost protection and coolant level	91	D.1.1	Yellow and orange symbols	117
17.3	Checking the coolant level	92		Index	118
17.4	Draining the coolant 	93			
17.5	Refilling the coolant 	94			
17.6	Changing the coolant 	95			
18	Cleaning, care	96			
18.1	Cleaning the motorcycle	96			
19	Storage	98			
19.1	Storage	98			
19.2	Preparing for use after storage	98			
20	Troubleshooting	99			
20.1	Indicator light in case of malfunction	99			
20.2	troubleshooting	99			
21	Technical specifications	101			
21.1	Engine	101			
21.1.1	Technical data - engine	101			
21.1.2	Capacities - engine	101			
21.2	Chassis	102			
21.2.1	Technical data - chassis	102			
21.2.2	Technical data - tires	103			
21.3	Electrics	103			
21.3.1	Battery	103			
21.3.2	Charger	103			
21.4	Fork	103			
21.4.1	Technical data - fork	103			
21.4.2	Capacities - fork	104			
21.5	Shock absorber	104			
21.5.1	Technical data - shock absorber	104			
21.6	Tightening torque	105			
21.6.1	engine tightening torques	105			
21.6.2	Chassis tightening torques	105			
22	Relevant documents	109			
22.1	Safety handbook	109			
23	Recycling	111			
23.1	Recycling	111			
	Notes	113			
A	Technical terms	113			
B	Operating material.....	114			
C	Cleaning agents.....	116			

1.1 Conventions

1.1.1 Icons

-  Indicates a desired result (e.g. of a work step or a function).
-  Indicates an undesired result (e.g. of a work step or a function).
-  All work marked with this symbol requires specialist knowledge and technical understanding. Ensure that this work is carried out or supervised by trained personnel from an authorized contractual partner, and that any special tools required are used.
-  Indicates a page reference.
-  Indicates information with more details.
-  Indicates a tip, e.g. to simplify work.
-  Indicates the result from a test step.
-  Indicates the end of an activity, including any rework.

1.1.2 Formatting

Proprietary name	Indicates a proprietary name.
Name[®]	Indicates a protected name.
Brand[™]	Indicates a brand available on the open market.
<u>Underlined terms</u>	Refer to technical details of the vehicle or indicate technical terms that are explained in the glossary.

1.1.3 Abbreviations

2-pc.	two-part
Part no.	Part number
or	respectively
approx.	circa
etc.	et cetera
poss.	possibly/possible
if necessary	if necessary
cmpl.	complete
min.	at least
no.	number
no fig.	no figure
s.	see
among others	among others/not limited to
and the like	and the like
etc.	et cetera
cf.	compare
e.g.	for example

2.1 Safety instructions

Function of the safety instruction

Safety instruction brings attention to dangers when handling the product. Hazards are classified, named, described, and supplemented with information on how to avoid them.

- If there is a safety instruction before a list of instructions, the danger exists throughout the entire activity.
- If there is a safety instruction immediately before an instruction, the next step presents a danger.

Safety instruction layout

All safety instructions are identified by a signal word and a warning symbol. The combination of signal word and warning symbol determines the degree of danger.



DANGER

Indicates an imminent danger that leads to serious injury or death.



WARNING

Indicates a potentially imminent danger that could lead to serious injury or death.



CAUTION

Indicates a potentially imminent danger that can lead to minor or slight injuries.



NOTE

Indicates a situation that can lead to damage to the product or the product environment.



NOTE

Indicates a situation that can lead to environmental damage.

2.2 Warning against tampering with the machine

No mechanical, electrical or electronic modifications may be made to the vehicle, since safe operation cannot be guaranteed otherwise.

Examples of inadmissible manipulation and modifications:

1. Opening the lithium-ion battery (LV traction battery) or the motor.
2. Use of the vehicle or the lithium-ion battery when proper maintenance has not been performed.
3. Use of the vehicle or the lithium-ion battery outside the use definition.
4. Use of a damaged lithium-ion battery.

2.3 Safe use



WARNING

Danger of accidents A lack of physical and mental readiness on the part of the child poses a major risk. Children often underestimate or fail to recognize dangerous situations.

- Your child must already be able to ride a bicycle.
- Your child must be able to put the vehicle upright independently after a fall.
- Your child must understand that regulations and instructions from you or from other guardians must be followed.
- Make it clear to your child that they should not, under any circumstances, operate the vehicle without supervision.
- Make sure that the riding mode is appropriate for your child's riding ability and for the riding conditions.
- If necessary, block the ride mode by removing the magnetic switch under the seat.
- Do not ask too much of your child.

- Do not consider participation in competitive activities until your child's stamina, riding techniques and motivation are at the necessary levels.
- Only let your child ride on the vehicle if they are physically and mentally ready.

**WARNING**

Danger of burns Some vehicle components become hot when the vehicle is operated.

- Do not touch any parts such as the engine, lithium-ion battery, damper, or brake system before these vehicle parts have cooled down.
- Allow the vehicle parts to cool down before performing any work on the vehicle.

This vehicle is a low-voltage electric motorcycle. For this reason, follow the safety and care instructions that apply when using an electric motor.

If the throttle grip is closed and no **recuperation** is activated, the vehicle continues to roll without much delay. The vehicle speed decreases on account of rolling resistance and air resistance.

Because this vehicle does not have a manual transmission, there is no clutch.

As with a conventional drive with a combustion engine, the operating temperature rises according to use and depending on the ambient temperature and the cleanliness of the cooling surfaces. If the temperature of the motor, the lithium-ion battery, or the electronics rises above the permissible operating temperature, the power of the vehicle will be reduced considerably. This protects the system against damage from overheating. When power reduction is imminent, the active riding mode indicator flashes. When power reduction is active, all three driving mode indicators light up. When all components have returned to their normal operating temperature, full system power is restored after restarting.

Only operate the vehicle when it is in perfect technical condition, in accordance with its intended use, and in a safe and environmentally compatible manner.

Have any faults that impair safety immediately remedied by an authorized contractual partner.

Adhere to the information and warning labels on the vehicle.

2.4 Fall or accident

If the vehicle is lying on its side, it switches from ready mode to standby mode after five seconds. To return the vehicle to ready mode, place the vehicle in the upright position and close the throttle grip beyond the basic position.

After a fall or accident, check the vehicle as usual when preparing for use.

2.5 Protective clothing

**WARNING**

Risk of injury Missing or poor protective clothing presents an increased safety risk.

- Ensure your child wears appropriate protective clothing such as helmet, boots, gloves as well as trousers and a jacket with protectors on all rides.
- Always use protective clothing for your child that is in good condition and meets the legal requirements.
- When you ride a motorcycle, set an example for your child and wear suitable protective clothing.

2.6 Work on vehicle, engine, and rechargeable lithium-ion battery



WARNING

Risk of injury There is a risk of electric shock when working on live components.

Work on live components requires special training, qualifications, and tools.

- Ensure that all work that is not described and explained is only carried out by specialists who have completed the necessary training.
- Do not open the electric motor or the lithium-ion accumulator.



WARNING

Risk of injury The vehicle runs quietly, even when it is ready to operate.

The vehicle can start to move in an uncontrolled manner if the throttle is accidentally touched while work is being performed on the vehicle.

- Ensure that the vehicle is switched off with the On/Off button and remains switched off before starting any work on the vehicle.
- Remove the magnetic switch from the holder before starting any work on the vehicle.
- Secure the vehicle against access by unauthorized persons while you are performing work on the vehicle.

Unless specified otherwise, the ignition must be switched off during all work (models with ignition lock, models with transponder key) or the engine must be at a standstill (models without ignition lock or transponder key). Special tools are required for some work. The tools are not part of the vehicle, but can be ordered using the number in parentheses. Example: bearing puller (15112017000)

Unless otherwise noted, normal conditions apply to all tasks and descriptions.

Ambient temperature	20 °C (68.0 °F)
Ambient air pressure	1,013 mbar (14.69 psi)
Relative air humidity	60 ±5 %

During assembly, use new parts to replace parts which cannot be reused (e.g. self-locking screws and nuts, expansion screws, seals, sealing rings, O-rings, pins, and lock washers).

A thread lock (e.g. **Loctite**®) is required for some screw connections. Observe the manufacturer's specific instructions for use.

If thread lock (e.g. **Precote**®) has already been applied to a new part, do not apply any additional thread lock.

After disassembly, clean the parts that are to be reused and check them for damage and wear. Replace damaged or worn parts.

After completing a repair or service, check the operating safety of the vehicle.

2.7 Environment

When you respect the rights of others and use your motorcycle legally, you will help protect the future of motorcycle sport and avoid most conflicts and problems.

When disposing of used oil, other operating and auxiliary fluids, and used components, comply with the applicable laws and regulations in your country.

When disposing of the lithium-ion battery (LV traction battery), observe the relevant laws and guidelines of your country.

Your authorized contractual partner can dispose of the LV traction battery free of charge and in an environmentally friendly manner.

As motorcycles are not subject to the EU regulations governing the disposal of end-of-life vehicles, there are no legal regulations that pertain to the disposal of an end-of-life motorcycle. An authorized partner will be happy to help.

Electrical devices like the battery charger may not be disposed of with household waste. Electrical devices must be disposed of through the appropriate recycling centers. Contact your municipality or your authorized contractual partner.

2.8 Owner's manual

It is important that you read this owner's manual carefully and completely before your child makes their first trip. The owner's manual contains useful information and many tips for you and your child on how to operate, handle, and service your motorcycle. This is the only way for you to find out how to ideally tune the vehicle and how to protect your child from injury.



Tip

Store the owner's manual on your terminal device, for example, so that you can read it whenever you need to.

If you would like to know more about the vehicle or have questions about the material, please contact an authorized partner.

The owner's manual is an important component of the vehicle. If the vehicle is sold, the owner's manual must be downloaded again by the new owner.

The owner's manual can be downloaded multiple times using the QR code or the link on the delivery certificate.

The owner's manual is also available for download from your authorized contractual partner and on the KTM website. You can also order a printed copy from your authorized contractual partner.

International KTM Website: <https://www.ktm.com>

2.9 Fire hazard



WARNING

Fire hazard Massive mechanical damage to the lithium ion accumulator can lead to a short circuit within the cell and spontaneous combustion.

- Contact the vehicle manufacturer's customer service immediately if the lithium ion accumulator is severely damaged.

There is no particular fire hazard for this vehicle when the rechargeable lithium-ion battery (LV traction battery) is intact.

However, should the vehicle catch fire, inform the fire department responsible that an electric vehicle with a rechargeable lithium-ion battery is on fire.

2.10 Use definition – intended use

This vehicle is designed and constructed to withstand the stresses and strains of regular racing if the maximum rider weight is not exceeded.



Note

- Only use this vehicle on designated tracks away from public roads.
- Only use the lithium-ion battery while it is inside the vehicle.

2.11 Improper use

The vehicle may only be used as intended.

Improper use can result in danger to people, property and the environment.

Any use of the vehicle beyond the intended and defined use constitutes misuse.

Improper use includes the use of operating and auxiliary materials that do not meet the required specifications for the respective use.

3.1 Manufacturer's warranty, implied warranty

The work prescribed in the service schedule must only be carried out in an authorized contractual partner and confirmed in the **KTM Dealer.net**, as otherwise all warranty claims will be void. Damage or secondary damage caused by tampering with and/or conversions on the vehicle are not covered by the manufacturer's warranty.

3.2 Auxiliary material, operating material

Use the operating and auxiliary substances (such as oils and lubricants) specified in the Owner's Manual.

3.3 Spare parts, accessories

For the safety of your child, only use spare parts and accessory products that are approved and/or recommended by KTM and have them installed by an authorized contractual partner. KTM accepts no liability for other products and any resulting damage or loss.

Certain spare parts and accessory products are specified in parentheses in the descriptions. Your authorized contractual partner will be happy to advise you.

The current **KTM PowerParts** for your vehicle can be found on the KTM website.

International KTM Website: <https://www.ktm.com>

3.4 Service

A prerequisite for perfect operation and prevention of premature wear is that the service, care, and tuning work on the engine and chassis is properly carried out as described in the owner's manual. An incorrect suspension setting can lead to damage and breakage of chassis components.

Use of the vehicle under arduous conditions, such as on sand or on wet, dusty and muddy surfaces, can result in significantly increased wear of components, such as the powertrain, brake system, air filter, or suspension components. For this reason, it may be necessary to inspect or replace parts before the next scheduled service interval.

Please adhere to the prescribed run-in times and service intervals at all times. Strictly adhering to this will ensure a much longer service life for your motorcycle.

The relevant mileage or time interval is whichever occurs first.

A list of services that have already been carried out on the vehicle can be found in the Service area on the international KTM website:

International KTM Website: <https://www.ktm.com>

Authorized contractual partners will be happy to answer any questions regarding the services performed.

A list of authorized contractual partners can be found on the KTM website.

3.5 Figures

Some of the figures in this document contain optional extras.

For clarity, some components may be shown disassembled or may not be shown at all. Disassembly is not always absolutely necessary in order to carry out the activities described. The textual information takes precedence.

3.6 Customer service

Your authorized contractual partner will be happy to answer any questions you may have regarding your vehicle and KTM.

A list of authorized partners can be found on the KTM website.

International KTM Website: <https://www.ktm.com>

3.7 Voltage supply



W00810-10

A rechargeable lithium-ion battery ① (LV traction battery) is installed in the vehicle. The LV traction battery supplies the electric motor ② and multifunction element ③ with voltage. The LV traction battery is firmly bolted to the frame and engine.



3.8 Operation at low temperatures

In order to protect the LV traction battery, the engine control reduces the power at low component temperatures. If the temperature of the LV traction battery is too low, the active ride mode indicator flashes. The vehicle can be operated without any problems. The LV traction battery is not damaged by the reduction in power. The LV traction battery warms up during vehicle operation. If the temperature of the LV traction battery exceeds a threshold value, full vehicle power is restored after the vehicle is restarted.

4.1 View of vehicle, front left (example)



A02965-10

- ① Handbrake lever  (p. 19)
- ② Magnetic switch under the seat  (p. 20)
- ③ Plug-in stand holder
- ④ Charging socket

4 View of the vehicle

4.2 View of vehicle, rear right (example)

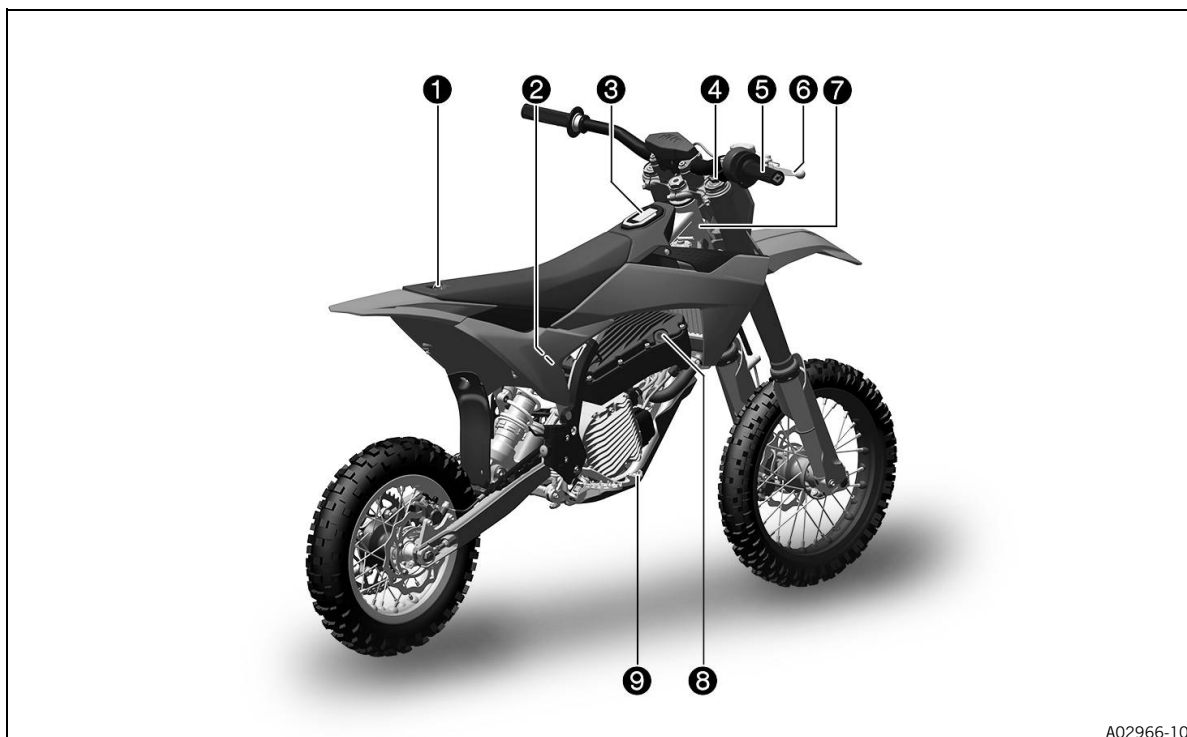

A02966-10

- | | |
|-------------------------------------|---|
| ❶ Quick release of seat | ❹ Handbrake lever 📖 (p. 19) |
| ❷ Shock absorber rebound adjuster | ❺ Vehicle identification number 📖 (p. 17) |
| ❸ Multifunctional element 📖 (p. 22) | ❻ On/Off button 📖 (p. 19) |
| ❹ Fork rebound adjustment | ❼ Brake pedal 📖 (p. 20) |
| ❺ Throttle grip 📖 (p. 19) | |

5.1 Vehicle identification number

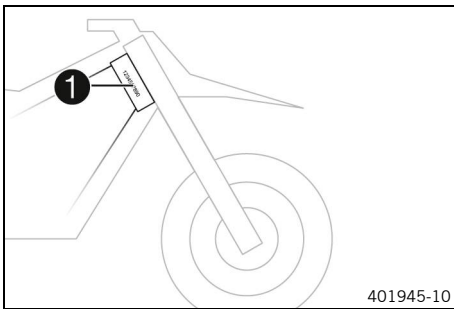

The vehicle identification number ❶ is stamped on the right-hand side of the steering head.

5.2 Frame label

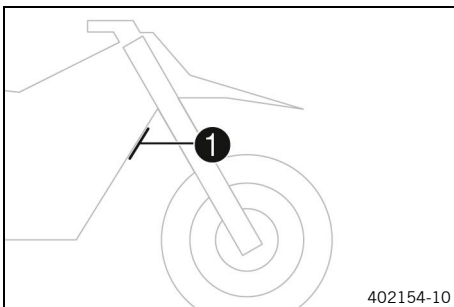

Frame label ❶ is located on the front frame tube.

5.3 Engine number

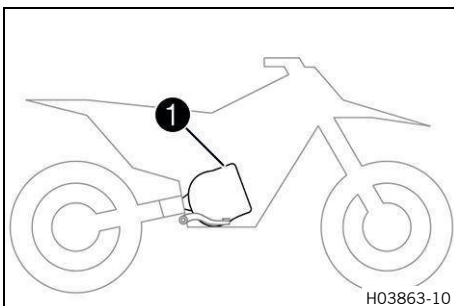

The engine number ❶ is located on the right side of the motor below the LV traction battery.

5.4 Fork part number

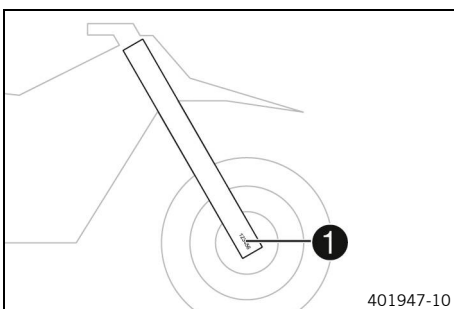

The fork article number ❶ is stamped on the outside of the axle clamp.

5.5 Shock absorber part number

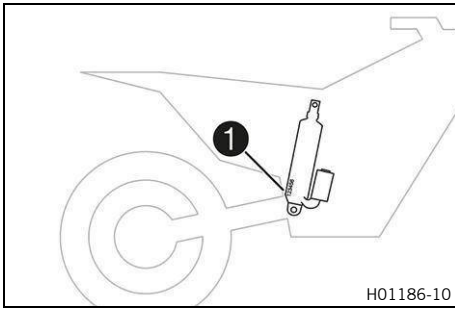

The shock absorber article number **1** is stamped on the bottom of the shock absorber toward the right-hand side.

5.6 Battery identification number

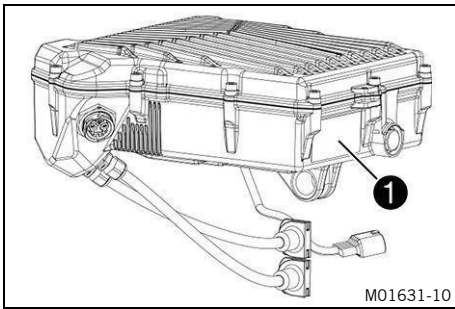

The battery identification number (**BIN**) **1** is located on a sticker on the LV traction battery.

6.1 Handbrake lever

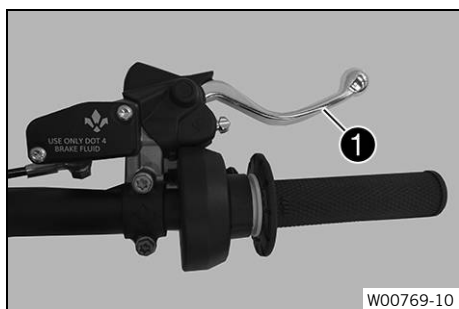

Hand brake lever **1** is fitted on the right side of the handlebar. The front brake is engaged using the hand brake lever.

6.2 Throttle grip

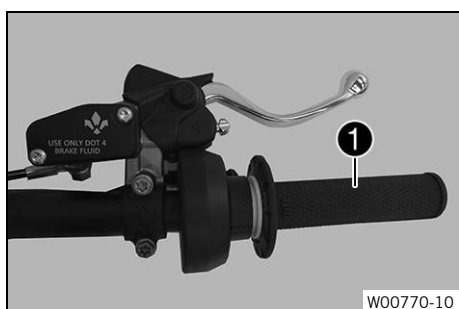

The throttle twist grip **1** is fitted on the right side of the handlebar.

After activation, the vehicle initially does not react to the throttle grip to prevent accidental acceleration.

The throttle grip must be closed beyond the basic position to activate the throttle response.

Only then is the vehicle ready to ride.

6.3 On/Off button



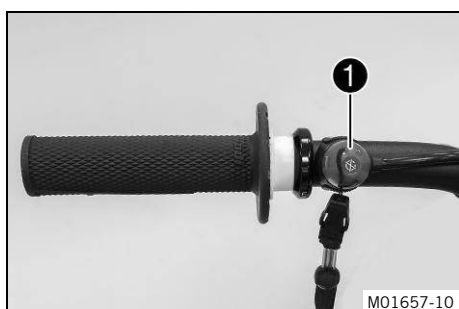

The On/Off button **1** is located on the right side of the LV traction battery.

6.4 Magnetic switch on handlebar



The holder for the red magnetic switch **1** is located on the left side of the handlebar.

Condition	Meaning
Magnetic switch  mounted on the handlebars	When the magnetic switch is mounted on the handlebar, the vehicle can be activated and ridden.
Magnetic switch  removed from handlebars	When the magnetic switch is removed from the handlebar, the vehicle cannot be activated or ridden.



WARNING

Risk of injury If the magnetic switch remains in the holder during a fall, the vehicle is not immediately deactivated.

- Make sure that the loop of the magnetic switch is securely attached to the user's protective clothing or wrist so that the magnetic switch is disconnected from the holder in the event of a fall.

If the red magnetic switch on the handlebar becomes disconnected from the support, for example in the event of a fall, the vehicle is deactivated.

By removing the red magnetic switch from the handlebar, the vehicle can be quickly deactivated in any operating state.

The red magnetic switch on the handlebar cannot be replaced with the gray magnetic switch under the seat (p. 20).

6.5 Magnetic switch under the seat

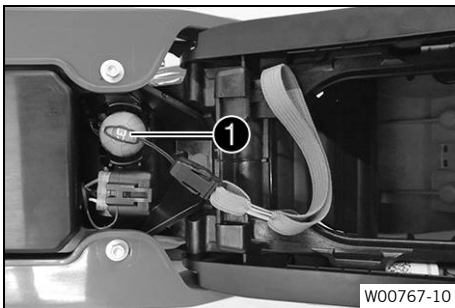

The holder for the gray magnetic switch **1** is located under the seat.

By removing the gray magnetic switch under the seat, you can prevent the riding mode from being changed.

Locking the ride mode is recommended if you have not yet gained sufficient experience for higher ride modes with more power and torque.

Condition	Meaning
Magnetic switch mounted under the seat	When the magnetic switch is mounted under the seat, the ride mode can be changed.
Magnetic switch removed	When the magnetic switch under the seat is removed, the ride mode cannot be changed.

The gray magnetic switch under the seat cannot be replaced with the red magnetic switch on the handlebar (p. 19).

6.6 Brake pedal

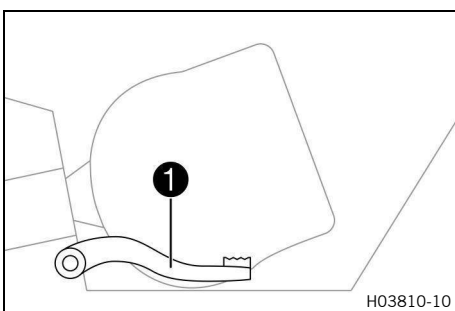

Brake pedal **1** is located in front of the right footpeg.

The rear brake is operated with the brake pedal.

6.7 Plug-in stand

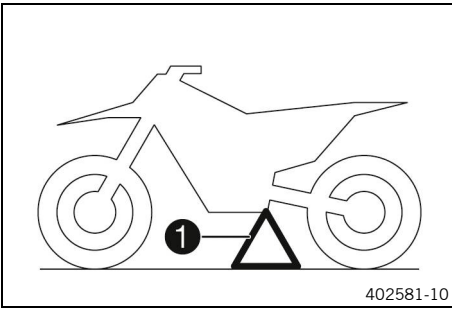

The fixture for plug-in stand ❶ is located on the frame on the left side of the vehicle.
The plug-in stand is used to park the motorcycle.



Note

Remove the plug-in stand before riding.

6.8 Diagnostic connector

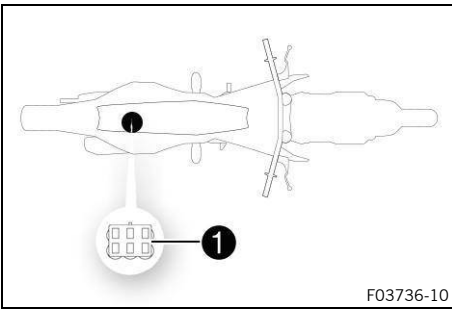

Diagnostics connector ❶ is located under the seat.





7 Multifunctional element

7.1 Multifunctional element

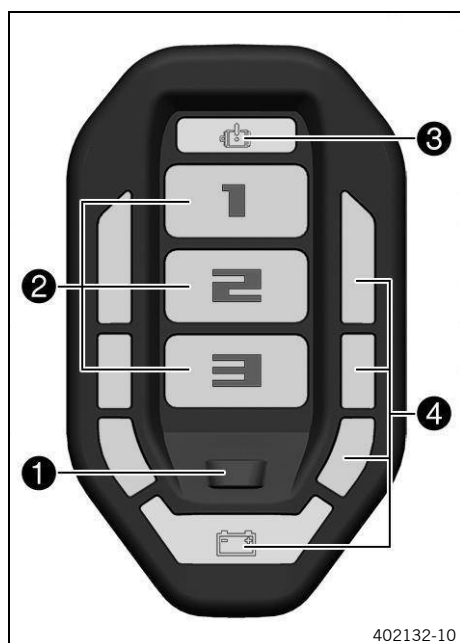
The multifunctional element is mounted in front of the seat.



Overview of multifunctional element

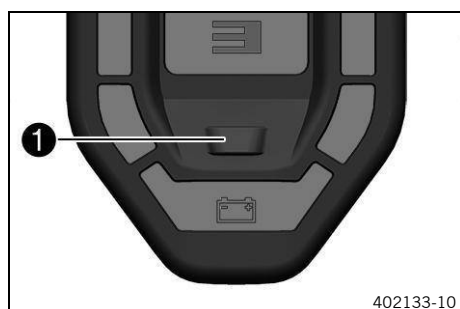

- ❶ Ride mode button  (p. 22)
- ❷ Riding mode indicator  (p. 23)
- ❸ Malfunction indicator lamp  (p. 23)
- ❹ Charging level indicator  (p. 24)

7.2 Ride mode button



The ride mode button ❶ determines the ride mode  (p. 23). The ride mode button is only active if the magnetic switch under the seat  (p. 20) is mounted.

Condition	Meaning
The riding mode button is active.	Vehicle is ready to operate.
The riding mode button is active.	Vehicle is ready to ride.
The riding mode button is not active.	All other vehicle conditions.

7.3 Riding mode indicator

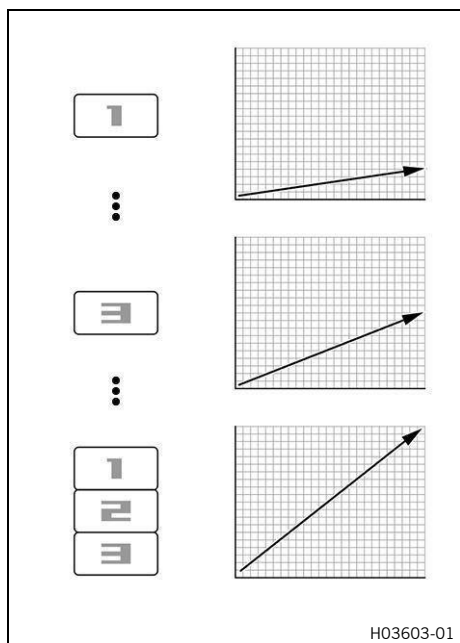

Red ride mode displays with the numbers **1**, **2**, or **3** show the ride mode selected.

Six ride modes are available. The riding modes define how the vehicle will respond to operation of the throttle grip.

The lowest torque is available in ride mode **1**. The maximum speed of the vehicle is limited. This ride mode is suitable for familiarization.

In ride modes **5** and **6**, the full torque is available. The maximum speed of the vehicle can be utilized. These ride modes should only be selected once sufficient riding experience has been gained and the vehicle can be handled safely.

The ride modes between **1** and **5** represent intermediate stages in terms of torque and maximum speed.

In ride modes **3** and **6**, an additional recuperation function (p. 29) is available.

Ride modes **1** to **3** are indicated by the illuminated single digit. When ride modes **4**, **5**, and **6** are activated, the activated ride mode is displayed as the sum of the illuminated digits.

i Note

When the magnetic switch under the seat (p. 20) is not mounted, the ride mode cannot be changed.

The ride modes are switched through in ascending order; after ride mode **6**, the ride mode jumps back to **1**.

7.4 Malfunction indicator lamp

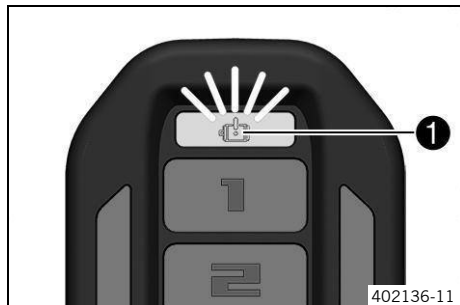

The warning tones emitted by the multifunctional element are synchronized with the flashing rhythm of malfunction indicator lamp **1**.

Condition		Meaning
	Malfunction indicator light lights up/flashes.	There is a malfunction in the vehicle electronic system.
	Malfunction indicator light lights up.	The system is carrying out a self-check or has been disabled during driving.

7.5 Charging level indicator

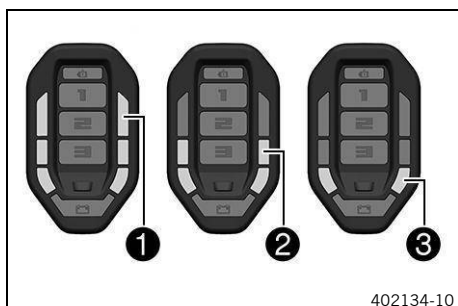

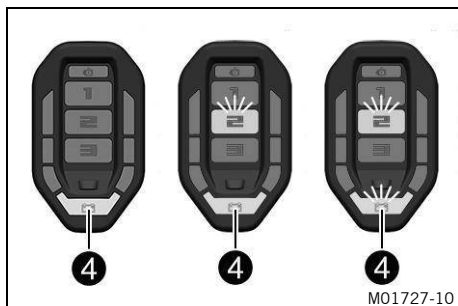

All segments **1** light up: charging level 70 % - 100%.
 Four segments **2** light up: charging level 50 % - 70 %.
 Two segments **3** light up: charging level 30 % - 50 %.

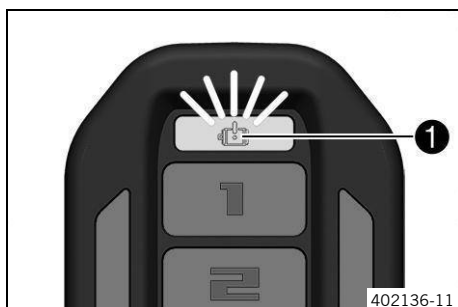

The last segment **4** lights up in yellow: charging level 20% - 30 %.
 The last segment **4** lights up in red and the driving mode indicator flashes red: charging level 10%–20%.
 The last segment **4** and the driving mode indicator light up in red: charging level 0%–10%.

7.6 Power reduction



If the charging level  (p. 24) of the LV traction battery is too low or the system temperature is outside of the permissible range, the power is automatically reduced.
 The selected ride mode and the malfunction indicator lamp flash when the power has been reduced.

i Note

The flash code of malfunction indicator light **1** can be used to determine the reason for the power reduction (see Troubleshooting chapter).

8.1 Notes on preparing for first use



WARNING

- Danger of accidents** The vehicle is not designed to carry passengers.
- Make it clear to your child that he or she must not carry a passenger.



WARNING

- Danger of accidents** The suspension components will become damaged or destroyed if overloaded.
- Make sure the maximum permissible weight of the rider is not exceeded.



WARNING

- Danger of accidents** The brake system fails in the event of overheating.
If the brake pedal is not released, the brake pads grind continuously.
- Ensure that your child raises his or her foot from the foot brake lever if he or she does not want to brake.



WARNING

- Risk of misappropriation** People who act without authorization endanger themselves and others.
- Never leave the vehicle unattended.
 - Secure the vehicle against unauthorized access.



WARNING

- Danger of accidents** A lack of physical and mental readiness on the part of the child poses a major risk. Children often underestimate or fail to recognize dangerous situations.
- Your child must already be able to ride a bicycle.
 - Your child must be able to put the vehicle upright independently after a fall.
 - Your child must understand that regulations and instructions from you or from other guardians must be followed.
 - Make it clear to your child that they should not, under any circumstances, operate the vehicle without supervision.
 - Make sure that the riding mode is appropriate for your child's riding ability and for the riding conditions.
 - If necessary, block the ride mode by removing the magnetic switch under the seat.
 - Do not ask too much of your child.
 - Do not consider participation in competitive activities until your child's stamina, riding techniques and motivation are at the necessary levels.
 - Only let your child ride on the vehicle if they are physically and mentally ready.



WARNING

- Danger of accidents** Different tire profiles on the front and rear wheels can make it more difficult to control the vehicle.
- Make sure that only tires of the same tread type are mounted to the front and rear wheel.



WARNING

- Risk of injury** Missing or poor protective clothing presents an increased safety risk.
- Ensure your child wears appropriate protective clothing such as helmet, boots, gloves as well as trousers and a jacket with protectors on all rides.
 - Always use protective clothing for your child that is in good condition and meets the legal requirements.
 - When you ride a motorcycle, set an example for your child and wear suitable protective clothing.

- Ensure that the pre-delivery inspection has been carried out by an authorized contractual partner.

8 Preparing for use

- ✓ The delivery certificate is transferred upon vehicle handover.
- Carefully read through the entire owner's manual together with the child before their first ride.



Note

Pay special attention to the safety instructions and to the risk of injury. Explain to the child the techniques of riding and falling, e.g. how shifting weight can influence handling characteristics.

- Familiarize the child with the controls.
- Adjust the basic position of the hand brake lever. (p. 68)
- Adjust the basic position of the brake pedal. (p. 75)
- Before using the vehicle for the first time, ensure that the basic settings of the chassis are suitable for the child's weight.
- Allow the child to become accustomed to the handling of the motorcycle on suitable terrain, preferably on a large, open field.



Note

Let the child get used to the brake system by just pushing them on the vehicle at first. Do not start the motor until the child is able to apply the necessary front brake pressure. Initially, let the child ride to another person who can help them stop and turn.

- Set up obstacles for the child to drive around in order to get used to the handling of the vehicle.
- Instruct the child to try to ride as slowly as possible and in a standing position to get a better feeling for the motorcycle.
- Do not let the child ride on terrain that exceeds their capabilities and experience.
- Instruct the child to hold the handlebar firmly with both hands and keep their feet on the footrests when riding.
- Make sure the maximum permissible weight of the rider is not exceeded.

Maximum rider weight	45 kg (99.2 lb)
Maximum rider size	< 130 cm (< 51.2 in)

- Check the spoke tension. (p. 86)

The spoke tension must be checked after half an hour of operation.

9.1 Checks and maintenance measures when preparing for use

i Note

Before every trip, check the condition of the vehicle and ensure that it is safe to operate. The vehicle must be in perfect technical condition when it is being operated.

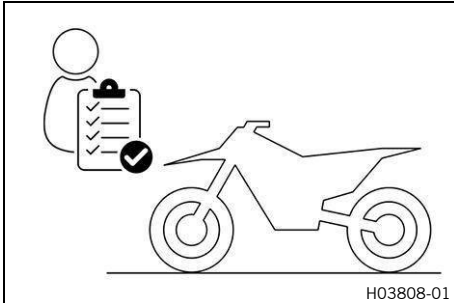

- Check the throttle grip, both magnetic switches, LV traction battery, multifunctional element, and electric engine for external damage.
 - Check the brake fluid level for the front brake. 📖 (p. 69)
 - Check the brake fluid level for the rear brake. 📖 (p. 76)
 - Check that the brake pads of the front brake are secured. 📖 (p. 71)
 - Check that the brake pads of the rear brake are secured. 📖 (p. 78)
 - Check that the brake system is functioning properly.
 - Check the chain for dirt. 📖 (p. 62)
 - Check the chain, rear sprocket, engine sprocket, and chain guide. 📖 (p. 64)
 - Check the chain tension. 📖 (p. 63)
 - Check the tire condition. 📖 (p. 84)
 - Check the tire pressure. 📖 (p. 85)
 - Check the spoke tension. 📖 (p. 86)
- The spoke tension must be checked regularly as incorrect spoke tension will severely impair riding safety.
- Clean the dust boots of the fork legs. 📖 (p. 48)
 - Bleed the fork legs. 📖 (p. 47)
 - Check the settings of all controls and ensure that they can be operated smoothly.
 - Check the tightness of the safety-relevant screws and nuts which are easily accessible.
 - Check the charging level of the LV traction battery.

9.2 Starting the vehicle

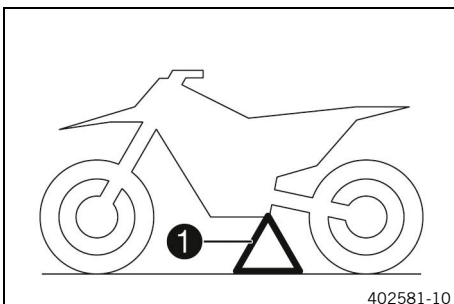

- Remove plug-in stand ❶.
 - Mount magnetic switch ~~⊗~~ on the support on the handlebar.
- To prevent unwanted activation, only mount the magnetic switch immediately before going on a ride.
- Press and hold the On/Off button until the multifunctional element lights up.
 - ✓ The vehicle is in standby mode.

9 Riding instructions

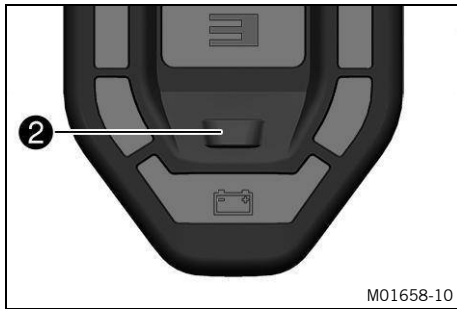

- Press ride mode button **2** to change the ride mode.

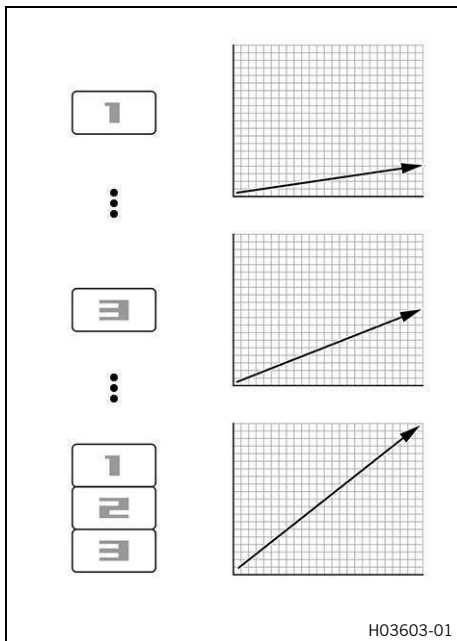

- Select one of the **ride modes**.
- Close the throttle grip beyond the basic position.
 - ✓ The vehicle emits a beep, is ready to ride, and reacts to the throttle grip.

9.3 Starting off

- Open the throttle carefully.

The plug-in stand must be removed before riding.

9.4 Braking



WARNING

Danger of accidents A spongy pressure point on the front or rear brake reduces the brake action.

- Make sure that your child does not ride the vehicle if the brake system has a spongy pressure point.



WARNING

Danger of accidents Braking with excessive force locks the wheels.

- Explain to your child that he or she must adapt the braking to the traffic situation and the road conditions.

**WARNING**

Danger of accidents Moisture and dirt impair the brake system.

- Explain to your child that he or she must brake carefully several times to dry out and remove dirt from the brake linings and the brake discs.

- On sandy, wet, or slippery surfaces, use mostly the rear brake if possible.
- Try to complete the braking procedure before riding into a curve.

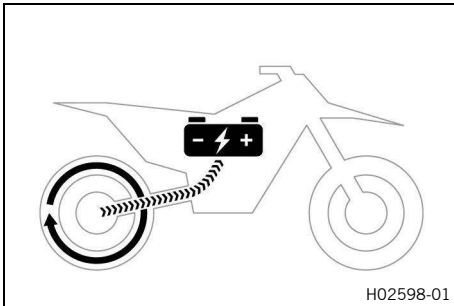
**9.5 Recuperation**

The LV traction battery is charged by the electric engine in **ride mode 3** and **6** (p. 23) when the throttle grip is closed beyond the basic position in overrun.

The recuperation function results in an increased motor braking effect.

The recuperation effect is stronger in **ride mode 6** than in **ride mode 3**.

**Note**

The recuperation function is not available in the remaining ride modes.

9.6 Stop, park**WARNING**

Risk of misappropriation People who act without authorization endanger themselves and others.

- Never leave the vehicle unattended.
- Secure the vehicle against unauthorized access.

**WARNING**

Danger of burns Some vehicle components become hot when the vehicle is operated.

- Do not touch any parts such as the engine, lithium-ion battery, damper, or brake system before these vehicle parts have cooled down.
- Allow the vehicle parts to cool down before performing any work on the vehicle.

**NOTE**

Material damage The vehicle may be damaged if parked incorrectly.

Damage can occur if the vehicle rolls away or falls over.

The components for parking the vehicle are designed only for the weight of the vehicle.

- Park the vehicle on a firm and level surface.
- Make sure that nobody sits on the vehicle when it is parked on a stand.

- Brake the motorcycle.
- Press and hold the On/Off button until the multifunctional element goes out.
- Remove magnetic switch  from the support on the handlebar.
- Park the motorcycle on firm ground.



9.7 Transportation



NOTE

Fire hazard Hot vehicle components pose a fire hazard and explosion risk.

- Do not park the vehicle near materials which are highly flammable or explosive.
- Allow the vehicle to cool down before covering it.



NOTE

Material damage The vehicle may be damaged if parked incorrectly.

Damage can occur if the vehicle rolls away or falls over.

The components for parking the vehicle are designed only for the weight of the vehicle.

- Park the vehicle on a firm and level surface.
- Make sure that nobody sits on the vehicle when it is parked on a stand.

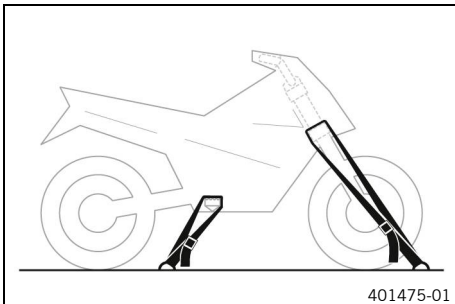















- Press and hold the On/Off button until the multifunctional element goes out.
- Remove magnetic switch  from the support on the handlebar.
- Use tension belts or other suitable devices to secure the motorcycle against falling over or rolling away.

10.1 Service schedule

Any further work that results from the service work must be ordered separately and invoiced separately. Different service intervals may apply in your country, depending on the local operating conditions. Individual service intervals and scopes may change in the course of technical developments. The most up-to-date service schedule is available for authorized contractual partners for the electronic proof of service. Your authorized contractual partner will be happy to advise you. Always bring the battery charger with you when having the vehicle serviced. The use of a service hour counter is recommended in order to be able to check the mileage at any time.

	Every 48 months					
	Every 12 months					
	Every 80 operating hours					
	Every 40 operating hours					
	Every 20 operating hours					
	After 10 operating hours					
Check the battery charger plug for damage and dirt.	○	●	●	●		
Read out the fault memory using the diagnostics tool.	○	●	●	●	●	●
Check that the electrical equipment is functioning properly.	○	●	●	●	●	●
Check and charge the LV traction battery.	○	●	●	●	●	●
Check that the brake pads of the front brake are secured. (p. 71)	○	●	●	●	●	●
Check that the brake pads of the rear brake are secured. (p. 78)	○	●	●	●	●	●
Check the brake discs. (p. 68)	○	●	●	●	●	●
Check the brake lines for damage and tightness.	○	●	●	●	●	●
Check the brake fluid level for the front brake. (p. 69)	○	●	●	●		
Change the brake fluid for the front brake.					●	●
Check the brake fluid level for the rear brake. (p. 76)	○	●	●	●		
Change the brake fluid for the rear brake.					●	●
Replace the sealing cup of the brake cylinder of the rear brake system.		●	●	●		
Check the free travel of the hand brake lever. (p. 68)	○	●	●	●	●	●
Check the free travel of the brake pedal. (p. 74)	○	●	●	●	●	●
Check the frost protection and coolant level. (p. 91)	○		●	●		
Change the coolant. (p. 95)						●
Check cables and wires for damage and ensure they are routed without kinks.	○	●	●	●	●	●
Check the frame. (p. 66)		●	●	●		
Check the swingarm. (p. 67)		●	●	●		
Check the swingarm bearing for play.		●	●	●		
Check the heim joint for play.		●	●	●		
Check the tire condition. (p. 84)	○	●	●	●	●	●
Check the tire pressure. (p. 85)	○	●	●	●	●	●
Check the wheel bearing for play.		●	●	●		
Check the hubs.		●	●	●		
Check the rim run-out.	○	●	●	●		

10 Service schedule

	Every 48 months					
	Every 12 months					
	Every 80 operating hours					
	Every 40 operating hours					
	Every 20 operating hours					
	After 10 operating hours					
Check the spoke tension.  (p. 86)	○	●	●	●	●	●
Check the chain, rear sprocket, engine sprocket, and chain guide.  (p. 64)	○	●	●	●	●	●
Check the chain tension.  (p. 63)	○	●	●	●	●	●
Grease all moving parts (e.g., hand lever, chain, etc.) and check for smooth operation. 	○	●	●	●	●	●
Carry out fork service. 			●	●		
Service the shock absorber. 				●		
Check the tightness of the safety-relevant screws and nuts which are easily accessible. 	○	●	●	●	●	●
Check the steering head bearing play.  (p. 54)	○	●	●	●		
Lubricate the steering head bearing.   (p. 56)					●	●
Check the pinion shaft bearings, O-rings and the bearing seals. 		●				
Change the pinion shaft bearings, the O-rings and the bearing seals. 			●	●		
Final check: check the operating safety of the vehicle and take for a test ride. 	○	●	●	●	●	●
Read out the fault memory after the test ride using the diagnostics tool. 	○	●	●	●	●	●
Enter the electronic proof of service in the contractual partner portal. 	○	●	●	●	●	●

- One-time interval
- Periodic interval

11.1 Checking the basic chassis setting with the rider's weight

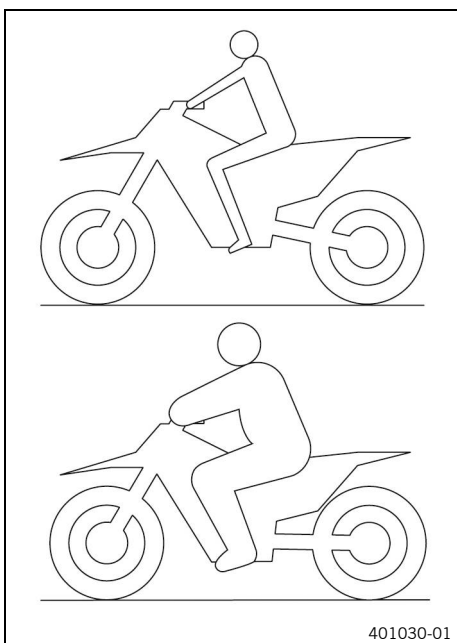

- For optimal motorcycle riding characteristics and to avoid damage to forks, shock absorbers, swingarm, and frame, the basic settings of the suspension components must match the rider's weight.

When adjusting the basic chassis setting, first adjust the shock absorber and then the fork.

- This vehicle is delivered pre-set for a standard rider's weight (with full protective clothing).

Standard rider's weight	25 kg ... 35 kg (55.1 lb ... 77.2 lb)
-------------------------	--

- If the rider's weight is above or below this range, the basic setting of the suspension components must be adjusted accordingly.
- Small weight differences can be compensated by adjusting the spring preload and the fork air pressure, but in the case of larger weight differences, the springs must be replaced.



11.2 Air suspension

Air suspension is used in this fork.

In this system, the suspension is located in the left fork leg and damping in the right fork leg.

The responsiveness is significantly improved on slightly uneven surfaces.

In normal ride mode, suspension is provided by an air cushion in combination with a steel spring.



Note

If the fork frequently bottoms out, then the fork air pressure must be increased to avoid damage to the fork and frame.

The air pressure in the fork can be quickly adjusted to the rider's weight, surface conditions, and the rider's preference using a fork air pump. The fork does not have to be dismantled. The time-consuming mounting of harder or softer fork springs is not required.

If the air chamber loses air due to a damaged seal, the fork will still not sag. In this case the air is retained in the fork with the support of the steel spring. The suspension travel is maintained as far as possible. The damping becomes harder, and the riding comfort is reduced.

The damping can be adjusted.

The rebound adjustment is located at the upper end of the right fork leg.

11.3 Compression damping of the shock absorber

The compression damping of the shock absorber is divided into two ranges: high-speed and low-speed.

High-speed and low-speed refer to the compression speed of the rear wheel suspension and not to the vehicle speed.

The high-speed compression has an effect, for example, when landing after a jump: the rear wheel suspension compresses quickly.

The low-speed compression has an effect, for example, when riding over long bumps: the rear wheel suspension compresses slowly.

These two ranges can be adjusted separately, although the transition between high-speed and low-speed is floating. As a result, changes in the high-speed range affect the compression damping in the low-speed range and vice versa.

11.4 Adjusting the low-speed compression damping of the shock absorber



CAUTION

Risk of injury Parts of the shock absorber will move erratically if the shock absorber is detached incorrectly. The shock absorber is filled with highly compressed nitrogen.

- Please follow the description provided.



Note

The effect of the low-speed compression adjustment can be seen in slow to normal compression of the shock absorber.

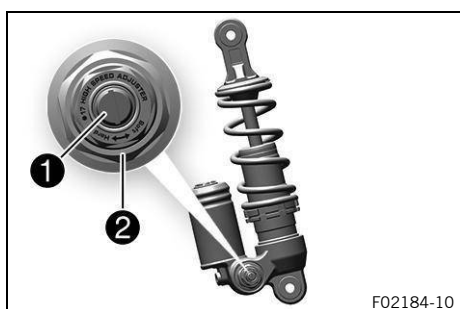

- Turn adjuster **1** clockwise with a screwdriver as far as the last perceptible click.

Do not loosen fitting **2**!

- Turn counterclockwise by the number of clicks corresponding to the shock absorber type.

Low-speed compression damping	
Comfort	18 clicks
Standard	15 clicks
Sport	12 clicks



Note

Turning clockwise increases damping; turning anticlockwise reduces damping.

11.5 Adjusting the high-speed compression damping of the shock absorber



CAUTION

Risk of injury Parts of the shock absorber will move erratically if the shock absorber is detached incorrectly. The shock absorber is filled with highly compressed nitrogen.

- Please follow the description provided.

i Note

The effect of the high-speed compression adjustment can be seen in the fast compression of the shock absorber.

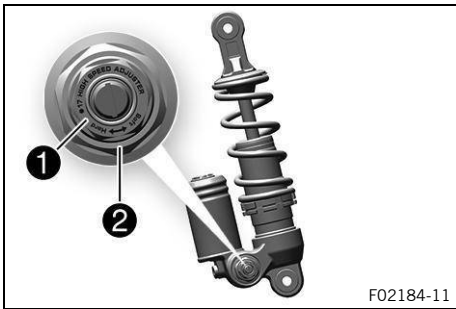

- Push the splash protector to the side.
- Turn adjuster ① all the way clockwise with an open end wrench.

Do not loosen fitting ②!

- Turn counterclockwise by the number of turns corresponding to the shock absorber type.

High-speed compression damping	
Comfort	2.5 turns (900°)
Standard	2 turns (720°)
Sport	1.5 turns (540°)

i Note

Turning clockwise increases damping; turning anticlockwise reduces damping.

- Position the splash protection.



11.6 Adjusting the rebound damping of the shock absorber



CAUTION

Risk of injury Parts of the shock absorber will move erratically if the shock absorber is detached incorrectly. The shock absorber is filled with highly compressed nitrogen.

- Please follow the description provided.

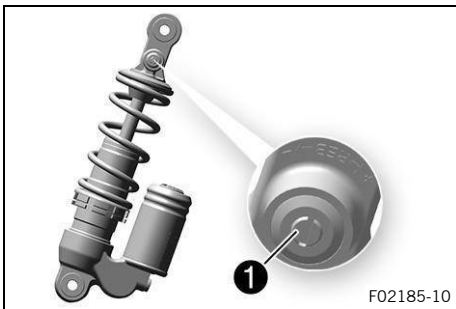

- Turn adjusting screw ① clockwise with a screwdriver as far as the last perceptible click.
- Turn counterclockwise by the number of clicks corresponding to the shock absorber type.

Rebound damping	
Comfort	18 clicks
Standard	15 clicks
Sport	12 clicks

i Note

Turning clockwise increases damping; turning anticlockwise reduces damping on rebound.



11.7 Measuring the dimension of the unloaded rear wheel

Preparatory work

- Raise the motorcycle with a lift stand. 📖 (p. 47)

Main work

- Position the sag gage in the rear axle and measure the distance to marking **SAG** on the rear fender.
- Note the value as dimension **A**.

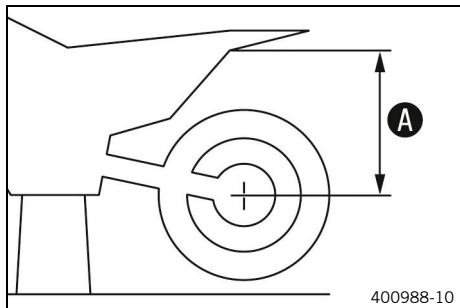

Reworking

- Remove the motorcycle from the lift stand. 📖 (p. 47)

11.8 Checking the static sag of the shock absorber

- Measure the dimension of the unloaded rear wheel. 📖 (p. 36)
- Hold the motorcycle upright with aid of an assistant.
- Measure the distance again between the rear axle and marking **SAG** on the rear fender using the sag gage.
- Note the value as dimension **B**.

i Note

The static sag is the difference between measurements **A** and **B**.

- Check the static sag.

Static sag	30 mm (1.18 in)
------------	--------------------

- » If the static sag is more or less than the specified value:
 - Adjust the preload for the shock absorber. 🔧 📖 (p. 37)

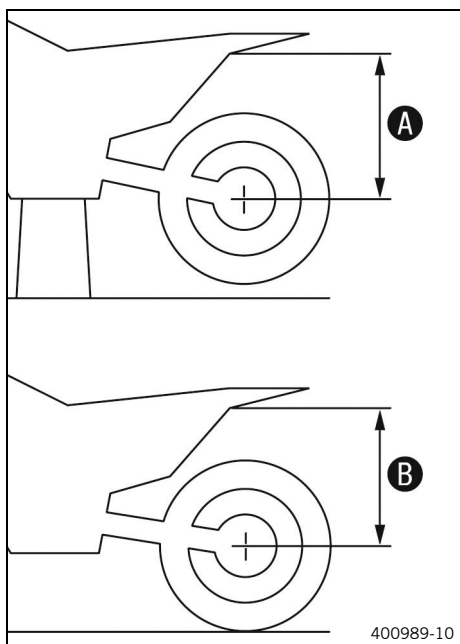

11.9 Checking the rider sag of the shock absorber

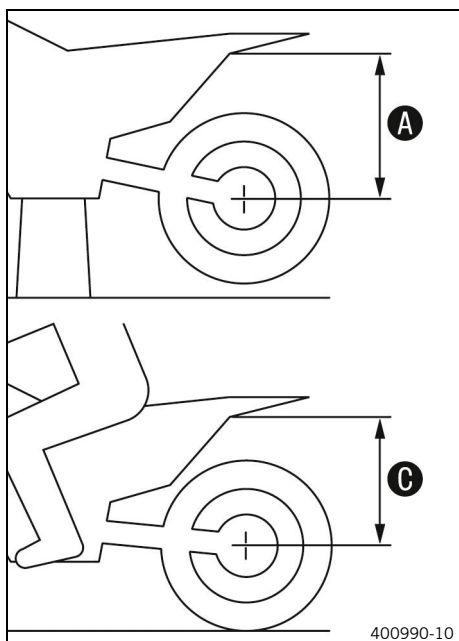

- Measure the dimension of the unloaded rear wheel. (p. 36)
- With another person holding the motorcycle, sit on the saddle with full protective clothing in a normal sitting position (feet on footrests) and bounce up and down a few times.
 - ✓ The rear wheel suspension levels out.
- With the help of another person, remeasure the distance between the rear axle and marking **SAG** on the rear fender using the sag scale.
- Note the value as dimension **C**.

i Note
The rider sag is the difference between measurements **A** and **C**.

- Check the rider sag.

Rider sag	80 mm (3.15 in)
-----------	--------------------

- » If the rider sag differs from the specified measurement:
 - Adjust the rider sag. (p. 38)

11.10 Adjusting the preload for the shock absorber



CAUTION

Risk of injury Parts of the shock absorber will move erratically if the shock absorber is detached incorrectly. The shock absorber is filled with highly compressed nitrogen.

- Please follow the description provided.

Preparatory work

- Raise the motorcycle with a lift stand. (p. 47)
- Remove the right side panel. (p. 60)
- Remove the shock absorber. (p. 57)
- After removing the shock absorber, clean it thoroughly.

Main work

- Measure the full spring length while it is under tension and note down the value.
- Loosen retaining ring **1**.
- Turn adjusting ring **2** until the spring is no longer under tension.

Hook wrench (T304)
Hook wrench (T1533)



Tip

If the spring cannot be fully released, the spring must be removed to accurately measure the spring length.

- Measure the total spring length while the spring is not under tension.

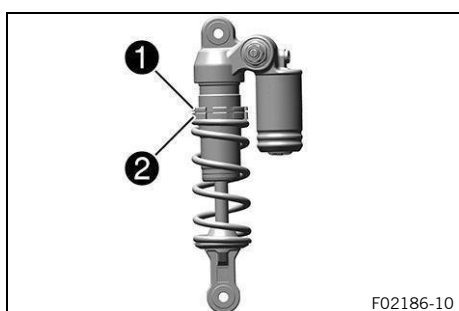

- Tighten the spring to the specified measurement by turning adjusting ring ②.

Preload	5 mm (0.20 in)
---------	-------------------

i Note

The spring preload is the difference between the relaxed spring length and the tensioned spring length.

Depending on the static sag and/or the rider sag, it may be necessary to increase or decrease the spring preload.

- Tighten retaining ring ①.

Reworking

- Install the shock absorber. 🛠️ 📖 (p. 58)
- Install the right side panel. 📖 (p. 61)
- Remove the motorcycle from the lift stand. 📖 (p. 47)

11.11 Adjusting the rider sag 🛠️

Preparatory work

- Raise the motorcycle with a lift stand. 📖 (p. 47)
- Remove the right side panel. 📖 (p. 60)
- Remove the shock absorber. 🛠️ 📖 (p. 57)
- After removing the shock absorber, clean it thoroughly.

Main work

- Select and mount a suitable spring.

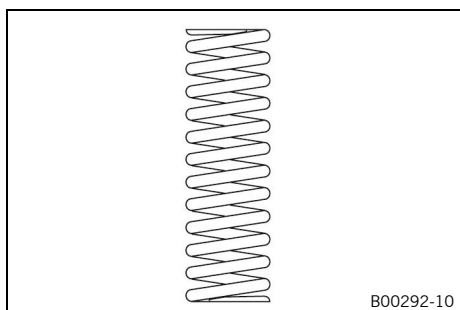

Spring rate	
Weight of rider: 15 kg ... 25 kg (33.1 lb ... 55.1 lb)	25 N/mm (142.8 lb _f /in)
Weight of rider (standard): 25 kg ... 35 kg (55.1 lb ... 77.2 lb)	30 N/mm (171.3 lb _f /in)
Weight of rider: 35 kg ... 45 kg (77.2 lb ... 99.2 lb)	35 N/mm (199.9 lb _f /in)

i Note

The spring rate is shown on the outside of the spring. Smaller weight differences can be compensated by changing the spring preload.

Reworking

- Install the shock absorber. 🛠️ 📖 (p. 58)
- Install the right side panel. 📖 (p. 61)
- Remove the motorcycle from the lift stand. 📖 (p. 47)
- Check the static sag of the shock absorber. 📖 (p. 36)

- Check the rider sag of the shock absorber. 📖 (p. 37)
- Adjust the rebound damping of the shock absorber. 📖 (p. 35)



11.12 Checking the basic setting of the fork



Note

For various reasons, no exact rider sag can be determined for the fork.

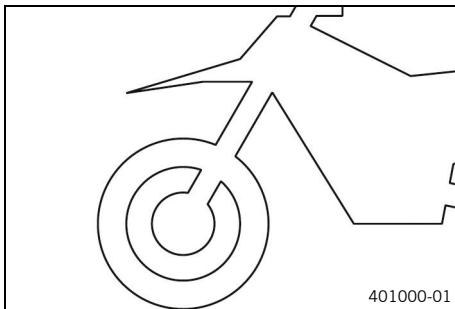

- Smaller differences in the rider's weight can be compensated for by the fork air pressure.
- However, if the fork frequently bottoms out (hard end stop on compression), the fork air pressure must be increased, within the specified values, to avoid damage to the fork and frame.



11.13 Adjusting the fork air pressure



WARNING

Danger of accidents Modifications to the suspension settings that are not properly coordinated can impair the handling and overload components.

- Only make adjustments within the recommended range.
- Make sure your child rides slowly to start with after making adjustments in order that he or she can assess the new handling characteristic.



Note

The air suspension is located in the left fork leg.
The rebound damping is located in the right fork leg.

Preparatory work

- Raise the motorcycle with a lift stand. 📖 (p. 47)

Check or adjust the air pressure 5 minutes, at the earliest, after the end of the ride and under the same conditions.

Main work

- Remove protection cap ①.
- Push together fork airpump ② fully.

Read the accompanying instructions.

Fork air pump (79412966100)

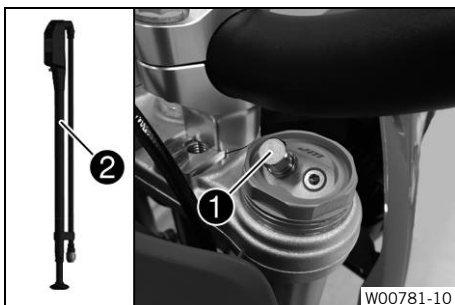

i Note

The fork air pump is included as part of the motorcycle's accessory pack.

- Connect the fork air pump to the left fork leg.
 - ✓ The fork air pump indicator switches on automatically.
 - ✓ A little air escapes from the fork leg when connecting.

i Note

This is due to the volume of the hose and is not due to a defect in the fork air pump or the fork.

- Adjust the air pressure as specified.

Air pressure	
Standard	3.5 bar (50.8 psi)

- Disconnect the fork air pump from the left fork leg.
 - ✓ When disconnecting, excess pressure will escape from the hose – the fork leg itself does not lose any air.
 - ✓ The fork air pump display switches off automatically after 80 seconds.
- Mount the protection cap.

Only mount the protection cap by hand.
--

Reworking

- Remove the motorcycle from the lift stand. 📖 (p. 47)

11.14 Adjusting the rebound damping of the fork

i Note

The hydraulic rebound damping determines the fork suspension behavior.



- Turn adjusters **1** clockwise all the way to the stop.

i Note

Adjusters **1** are located at the top end of the fork legs.

- Turn counterclockwise by the number of clicks corresponding to the fork type.

Rebound damping	
Standard	15 clicks

i Note

Turning clockwise increases damping; turning anticlockwise reduces damping on rebound.

11.15 Handlebar position

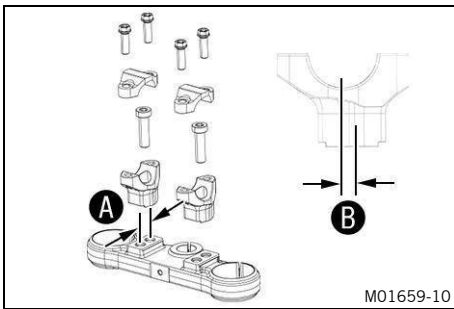

On the upper triple clamp, there are 2 holes at a distance of **A** to each other.

Hole distance A	15 mm (0.59 in)
------------------------	--------------------

The holes on the handlebar supports are placed at a distance of **B** from the center.

Hole distance B	3.5 mm (0.138 in)
------------------------	----------------------

The handlebar supports can be mounted in four different positions. This allows the handlebar to be mounted in the most comfortable position for the rider.

11.16 Adjusting the handlebar position



WARNING

Danger of accidents A repaired handlebar poses a safety risk.

If the handlebar is bent or straightened, the material becomes fatigued. The handlebar may break as a result.

- Change the handlebar if the handlebar is damaged or bent.

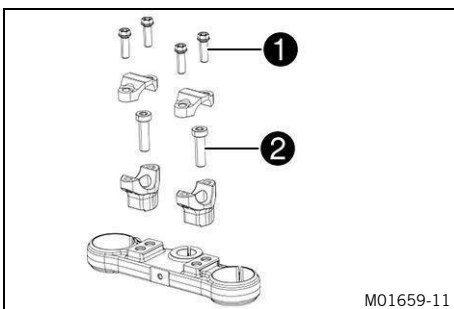

- Remove **1** screws.
- Take off the handlebar clamps.
- Remove the handlebar and lay it to one side.

Protect the components against damage by covering them.

Do not kink the cables or lines.

- Remove screws **2** and take off the handlebar supports.
- Place handlebar supports in required position.
- Mount and tighten screws **2**.

Screw, handlebar mount	
M10	40 Nm (29.5 ft·lb _r) Loctite® 243

Mount the left and right handlebar supports in the same position.

- Position the handlebar.

Make sure the cables and wiring are positioned correctly.

- Position the handlebar clamps.
- Mount screws **1** and tighten evenly.

Handlebar clamp screw	
M8	20 Nm (14.8 ft·lb _r)

Make sure the installed gap widths are even.

12.1 Seat height adjustment options

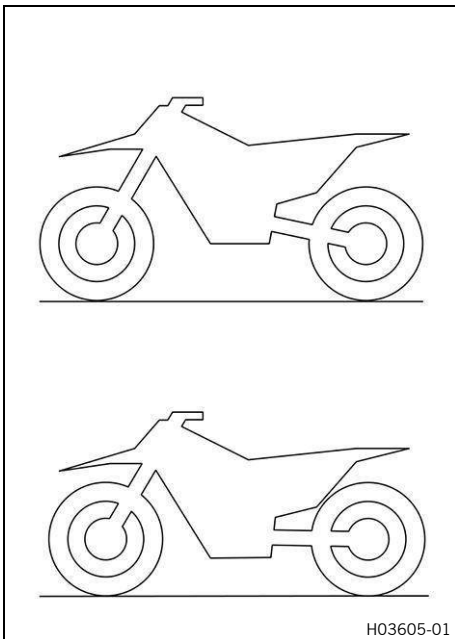

This vehicle offers several options for adjusting the seat height to the rider's height.

The seat height can be changed with the mounting position of the fork, shock absorber, and frame.

i Note

When adjusting the seat height on the fork and shock absorber, make sure that the vehicle is as straight as possible after completing the work.

If the seat height on the shock absorber is set low, the fork should be pushed through further and vice versa.

12.2 Adjusting the seat height on the shock absorber



WARNING

Danger of accidents Modifications to the suspension settings that are not properly coordinated can impair the handling and overload components.



- Only make adjustments within the recommended range.
- Make sure your child rides slowly to start with after making adjustments in order that he or she can assess the new handling characteristic.



Note

If the seat height is adjusted on the shock absorber, the seat height should also be adjusted on the fork.

Preparatory work

- Raise the motorcycle with a lift stand.  (p. 47)
- Remove the right side panel.  (p. 60)

Main work

- Hold the rear wheel with the link fork and remove screw **1**.
- Position the shock absorber according to the required seat height.

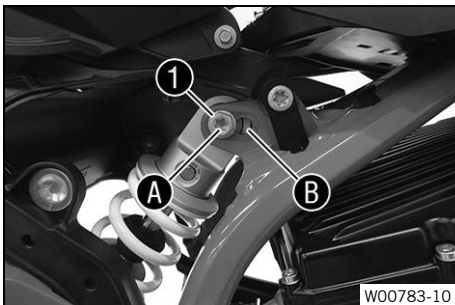



High seat position	A
Low seat position	B

- Mount and tighten screw **1**.

Top shock absorber screw	
M10×42	45 Nm (33.2 ft·lb.) Loctite® 243

Reworking

- Install the right side panel.  (p. 61)
- Remove the motorcycle from the lift stand.  (p. 47)



12.3 Adjusting the seat height on the fork



WARNING

Danger of accidents Modifications to the suspension settings that are not properly coordinated can impair the handling and overload components.



- Only make adjustments within the recommended range.
- Make sure your child rides slowly to start with after making adjustments in order that he or she can assess the new handling characteristic.



Note

The seat height can be infinitely adjusted by pushing the fork legs through.
If the seat height is adjusted on the fork, the seat height should also be adjusted on the shock absorber.

Preparatory work

- Raise the motorcycle with a lift stand.  (p. 47)
- Remove the front wheel.   (p. 81)

12 Seat height

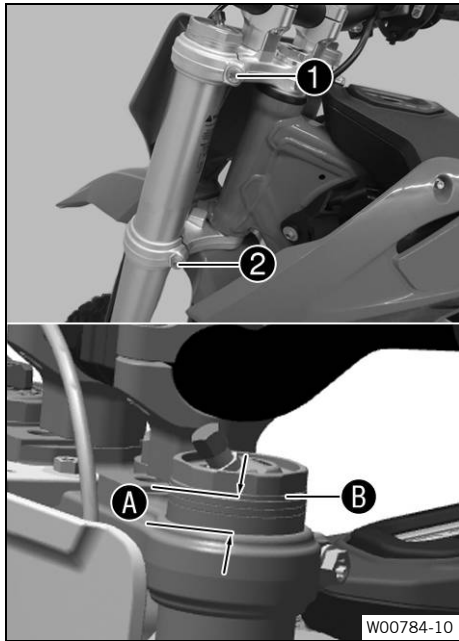

Main work

- Loosen screw ①.
- Loosen screw ②.
- Position the fork leg according to the required seat height.

Condition

- + Seating position as low as possible, fork fully inserted

Maximum distance A between lower edge of screw cap and upper edge of triple clamp	18 mm (0.71 in)
--	--------------------

Condition

- + Seating position as high as possible, fork pulled out completely

Bottom edge of screw cap B closes flush with the upper edge of the triple clamp.

Position the fork leg only within the described range.

- Tighten screw ②.

Screw, bottom triple clamp	
M8	15 Nm (11.1 ft·lb _f)

- Tighten screw ①.

Screw, top triple clamp	
M8	20 Nm (14.8 ft·lb _f)

- Repeat the procedure on the other fork leg.

Position both fork legs equally.

Reworking

- Install the front wheel. (p. 81)

12.4 Adjusting the seat height on the frame

Preparatory work

- Remove the seat. (p. 59)
- Remove the right side panel. (p. 60)
- Remove the left side panel. (p. 59)

Main work

- Remove screws ①.
- Pull the spoiler off the side of the quick-release fasteners.
- Remove the spoiler to the rear.

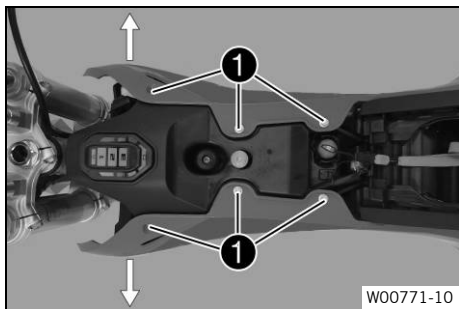

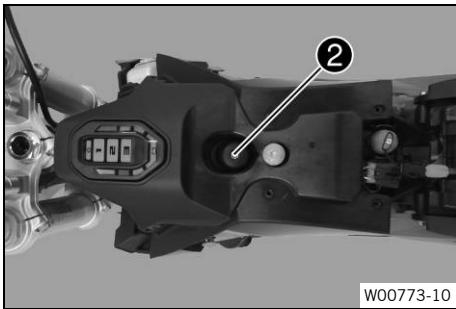

- Remove screw 2.

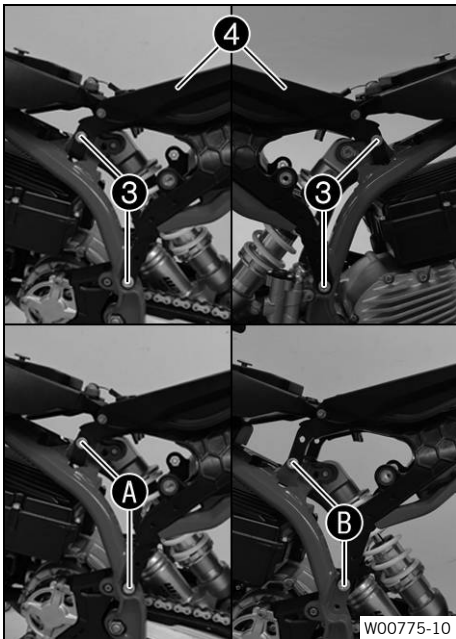

- Remove screws 3 and position subframe 4 at the drill holes at the desired seat height.

Low seating position	Drill holes A
High seating position	Drill holes B

- Mount and tighten screws 3.

Subframe screw	
M8	30 Nm (22.1 ft·lb _f) Loctite® 2701

Condition: High seating position

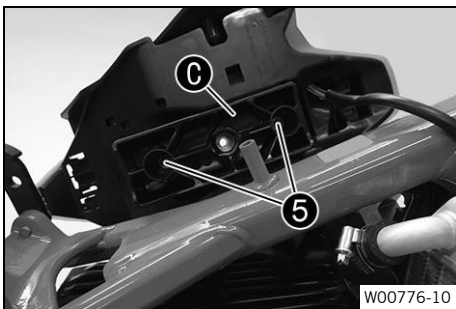

- Place tank adapter C on the linkage bracket.
- Mount and tighten screws 5.

Remaining screws on chassis	
EJOT PT® – K60×20	2 Nm (1.5 ft·lb _f)

Condition: Low seating position

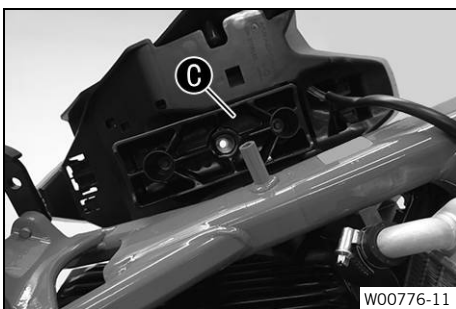

- Ensure that tank adapter C is removed from the linkage bracket.

i Note
Keep the tank adapter for later installation.

12 Seat height

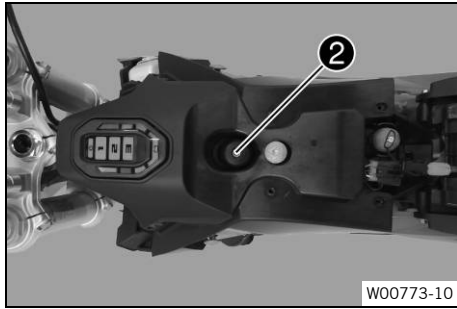

- Mount and tighten screw **2**.

Remaining screws on chassis	
M6	10 Nm (7.4 ft·lb _f)

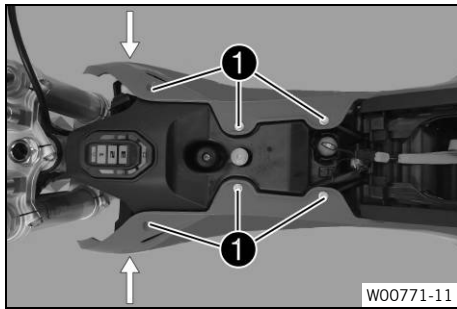

- Position the spoiler on the holding lugs and push forward from the rear.
- Engage the spoiler in the quick lock fasteners.
- Mount and tighten screws **1**.

Remaining screws on chassis	
EJOT PT® – K60×20	2 Nm (1.5 ft·lb _f)

Reworking

- Install the left side panel. 📖 (p. 60)
- Install the right side panel. 📖 (p. 61)
- Mount the seat. 📖 (p. 59)

13.1 Raising the motorcycle with a lift stand



NOTE

Material damage The vehicle may be damaged if parked incorrectly.

Damage can occur if the vehicle rolls away or falls over.

The components for parking the vehicle are designed only for the weight of the vehicle.

- Park the vehicle on a firm and level surface.
- Make sure that nobody sits on the vehicle when it is parked on a stand.

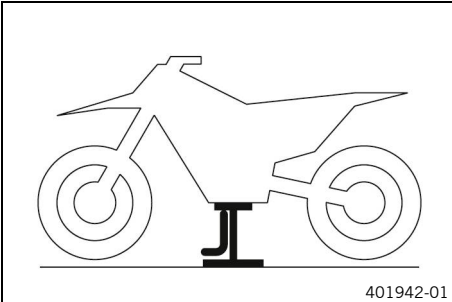

- Raise the motorcycle with a suitable lift stand by the frame under the engine.
- ✓ Neither wheel is in contact with the ground.
- Secure the motorcycle against falling over.

13.2 Removing the motorcycle from the lift stand



NOTE

Material damage The vehicle may be damaged if parked incorrectly.

Damage can occur if the vehicle rolls away or falls over.

The components for parking the vehicle are designed only for the weight of the vehicle.

- Park the vehicle on a firm and level surface.
- Make sure that nobody sits on the vehicle when it is parked on a stand.

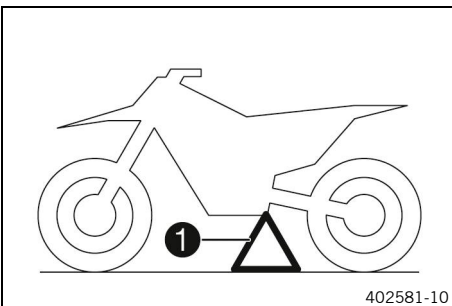

- Remove the motorcycle from the lift stand.
- Remove the lift stand.
- To park the motorcycle, insert plug-in stand ① into the plug-in stand bracket on the left side of the vehicle.

Remove the plug-in stand before riding.

13.3 Bleeding the fork legs

Preparatory work

- Raise the motorcycle with a lift stand. (p. 47)

13 Service work on the chassis

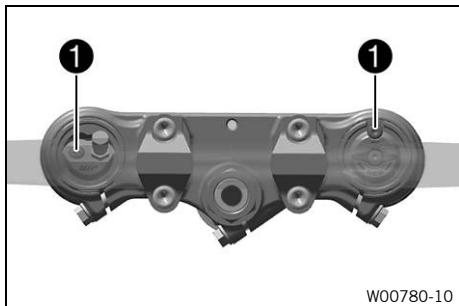

Main work

- Loosen bleeder screw 1.
- ✓ Any excess pressure escapes from the inner fork.
- Tighten the bleeder screw.

Reworking

- Remove the motorcycle from the lift stand. (p. 47)

13.4 Cleaning the dust boots of the fork legs

Preparatory work

- Raise the motorcycle with a lift stand. (p. 47)
- Remove the fork protector. (p. 49)

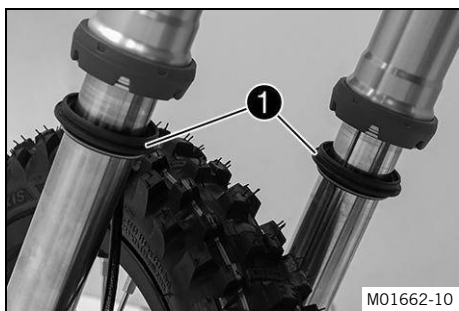

Main work

- Push dust boot 1 downward on both fork legs.

Note

The dust boots should remove dust and coarse dirt particles from the inner fork tubes. Over time, dirt can accumulate behind the dust boots. If this dirt is not removed, the seals rings behind can start to leak.



WARNING

Danger of accidents Oil, grease or wax on the brake discs reduces the brake action.

- Always keep the brake discs free of oil, fat and wax.
- Clean the brake discs with brake cleaner when necessary.

- Clean and oil the dust boots and the inner fork tube of both fork legs.

Universal oil spray (p. 114)

- Press the dust boots back into their installation position.
- Remove excess oil.

Reworking

- Install the fork protector. (p. 49)
- Remove the motorcycle from the lift stand. (p. 47)

13.5 Removing the fork protector

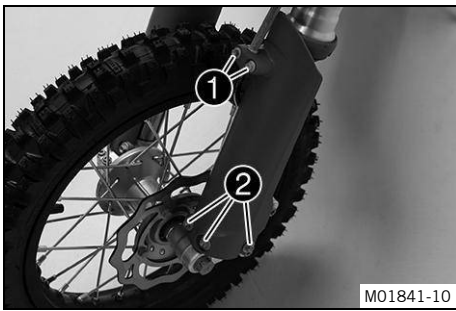

- Remove screw **1** and take off the clamp.
- Remove screws **2** on the left and right rear fork leg.
- Take off the fork protector.

13.6 Installing the fork protector

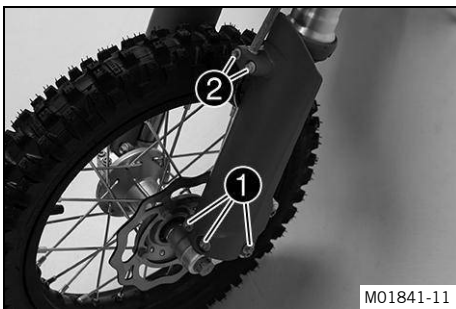

- Position the fork protector on the left and right fork leg.
- Mount and tighten screws **1** on both fork legs.

Remaining screws on chassis	
M6	10 Nm (7.4 ft·lb _f)

- Position the brake line and the clamp.
- Mount and tighten screws **2**.

Screw, brake line holder on fork protector	
EJOT PT® – K60×20 – AL	2 Nm (1.5 ft·lb _f)

13.7 Removing the fork legs

Preparatory work

- Raise the motorcycle with a lift stand. 📖 (p. 47)
- Remove the front wheel. 🛠️ 📖 (p. 81)

Main work

- Remove screw **1** and take off the clamp.
- Remove screws **2** and take off the brake caliper.
- Allow the brake caliper and the brake line to hang loosely to the side.

Do not kink the brake line.

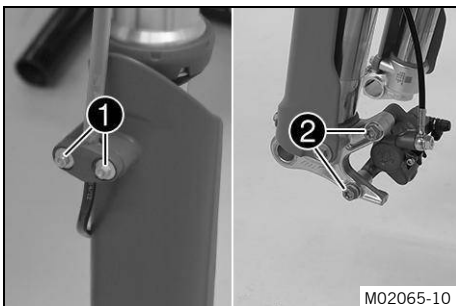

13 Service work on the chassis

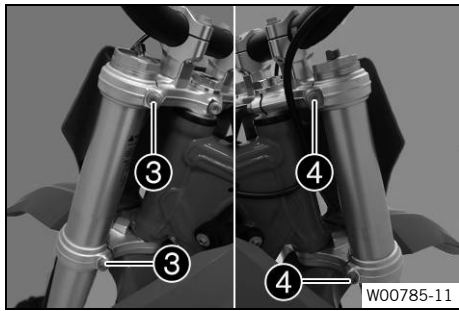

- Note the installation position of the fork legs.
- Loosen screws 3. Remove the left fork leg.
- Loosen screws 4. Remove the right fork leg.

13.8 Installing the fork legs

Main work

- Select one of the following alternatives.

Condition: Individual installation position

- Position the fork legs.

Observe the position determined during removal.

- ✓ Bleeder screws 1 are positioned as shown.

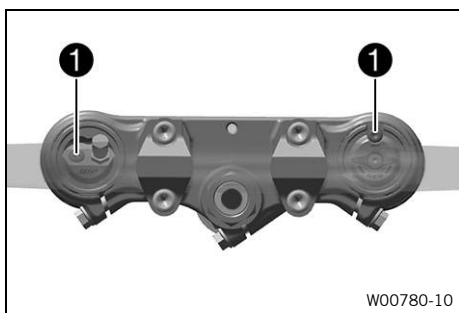

Condition: Standard installation position

- Position the fork legs.

- ✓ Bleeder screws 1 are positioned as shown.

- ✓ The second milled groove (from the top) is flush with the upper edge of the upper triple clamp.

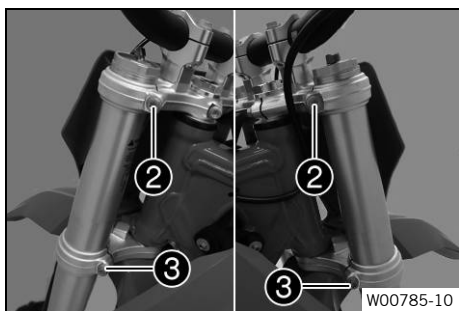
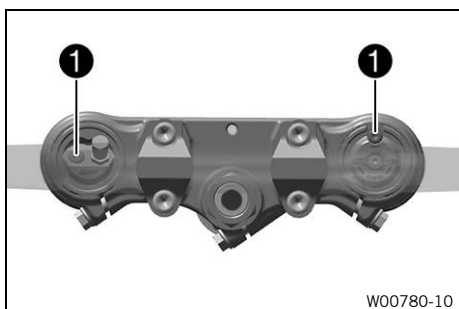

- Tighten screws 2.

Screw, top triple clamp	
M8	20 Nm (14.8 ft·lb _f)

- Tighten screws 3.

Screw, bottom triple clamp	
M8	15 Nm (11.1 ft·lb _f)

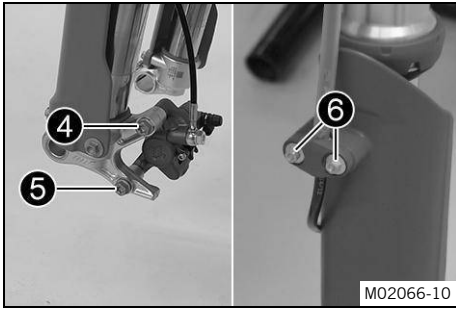

- Position the brake caliper, mount screw ④, and tighten.

Screw, front brake caliper	
M8×35	20 Nm (14.8 ft·lb _r) Loctite® 243

- Mount and tighten screw ⑤.

Screw, front brake caliper	
M8×35	20 Nm (14.8 ft·lb _r) Loctite® 243

- Position the brake line and the clamp.
- Mount and tighten screws ⑥.

Screw, brake line holder on fork protector	
EJOT PT® – K60×20 – AL	2 Nm (1.5 ft·lb _r)

Reworking

- Install the front wheel. 🛠️ 📖 (p. 81)

13.9 Removing the lower triple clamp 🛠️

Preparatory work

- Raise the motorcycle with a lift stand. 📖 (p. 47)
- Remove the front wheel. 🛠️ 📖 (p. 81)
- Remove the fork legs. 🛠️ 📖 (p. 49)
- Remove the number plate. 📖 (p. 56)
- Remove the front top fender. 📖 (p. 57)

Main work

- Remove screw ①.
- Remove the cable tie on the magnetic switch wire from the handlebar.
- Release screw ②, take off the upper triple clamp with the handlebar and set aside.

Protect the components against damage by covering them.
Do not kink the cables or lines.

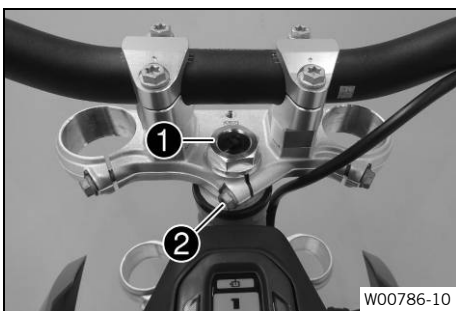

13 Service work on the chassis

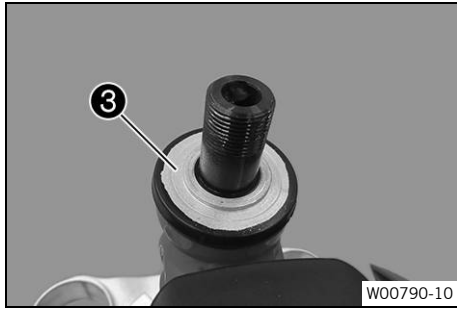

- Remove protective ring ③.
- Remove the steering stem from the lower triple clamp.
- Remove the upper steering head bearing.

13.10 Installing the lower triple clamp

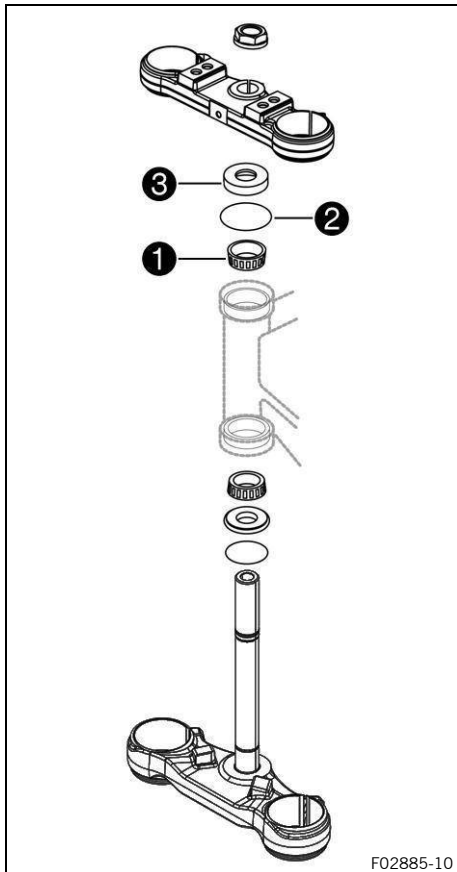

Main work

- Clean the bearing and sealing elements, check for damage, and grease.

High viscosity grease (p. 114)

- Insert the lower triple clamp with the steering stem.
- Mount upper steering head bearing ①.
- Check that the O-ring at the top ② is correctly positioned.
- Push on protective ring ③.

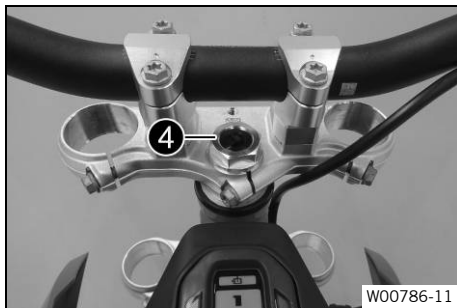

- Position the upper triple clamp and handlebar.
- Mount nut ④, but do not tighten yet.

- Select one of the following alternatives.
Condition: Individual installation position

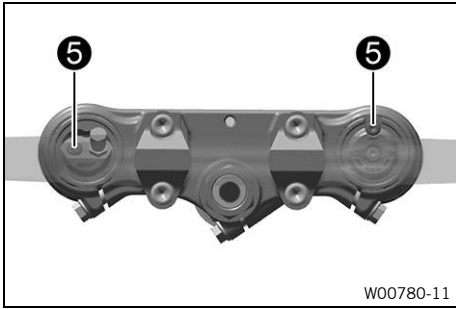

- Position the fork legs.

Observe the position determined during removal.

- ✓ Bleeder screws **5** are positioned as shown.

Condition: Standard installation position

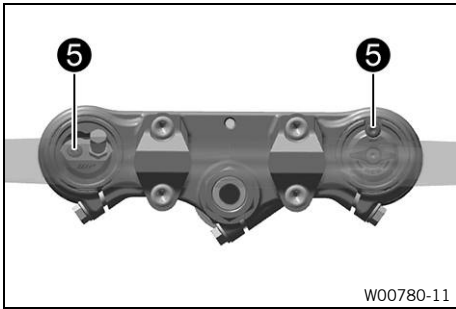

- Position the fork legs.

- ✓ Bleeder screws **5** are positioned as shown.

- ✓ The second milled groove (from the top) is flush with the upper edge of the upper triple clamp.

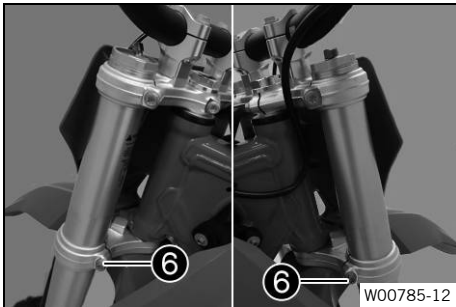

- Tighten screws **6**.

Screw, bottom triple clamp	
M8	15 Nm (11.1 ft·lb _r)



- Tighten screw **4**.

Screw, steering head	
M16×1.5	10 Nm (7.4 ft·lb _r)

- Tighten screw **7**.

Screw, steering stem	
M8	20 Nm (14.8 ft·lb _r)

- Using a plastic hammer, tap lightly on the upper triple clamp to avoid stresses.

- Tighten screws **8**.

Screw, top triple clamp	
M8	20 Nm (14.8 ft·lb _r)

- Fix the magnetic switch wire to the handlebar with a new cable tie.

13 Service work on the chassis

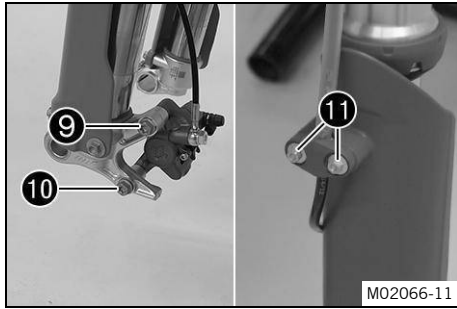

- Position the brake caliper, mount screw 9, and tighten.

Screw, front brake caliper	
M8×35	20 Nm (14.8 ft·lb _f) Loctite® 243

- Mount and tighten screw 10.

Screw, front brake caliper	
M8×35	20 Nm (14.8 ft·lb _f) Loctite® 243

- Position the brake line and the clamp.
- Mount and tighten screws 11.

Screw, brake line holder on fork protector	
EJOT PT® – K60×20 – AL	2 Nm (1.5 ft·lb _f)

Reworking

- Install the front top fender. 📖 (p. 57)
- Mount the number plate. 📖 (p. 56)
- Check that the cable and brake line are routed correctly.
- Install the front wheel. 🛠️ 📖 (p. 81)
- Check the steering head bearing play. 📖 (p. 54)
- Remove the motorcycle from the lift stand. 📖 (p. 47)

13.11 Checking the steering head bearing play



WARNING

Danger of accidents Incorrect steering head bearing play can impair the handling characteristic and damage components.

- Correct incorrect steering head bearing play immediately.



Note

If the vehicle is operated for a lengthy period with play in the steering head bearing, the bearings and the bearing seats in the frame can become damaged.

Preparatory work

- Raise the motorcycle with a lift stand. 📖 (p. 47)

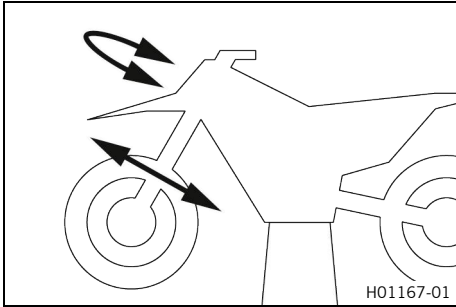

Main work

- Bring the handlebars into the straight-ahead position and move the fork legs back and forth in the direction of travel.

Play should not be detectable on the steering head bearing.

- » If there is detectable play:
 - Adjust the steering head bearing play. 🛠️ 📖 (p. 55)

- Move the handlebar back and forth over the entire steering range.

It must be possible to move the handlebar easily over the entire steering range.

There should be no detectable detent positions.

- » If detent positions are detected:
 - Adjust the steering head bearing play. 🛠️ 📖 (p. 55)
 - Check steering head bearing, replace if necessary.

Reworking

- Remove the motorcycle from the lift stand. 📖 (p. 47)

13.12 Adjusting the steering head bearing play 🛠️

Preparatory work

- Raise the motorcycle with a lift stand. 📖 (p. 47)



Main work

- Loosen screws ❶.
- Loosen screw ❷.
- Loosen and retighten screw ❸.

Screw, steering head	
M16×1.5	10 Nm (7.4 ft·lb _f)

- Using a plastic hammer, tap lightly on the upper triple clamp to avoid stresses.

- Tighten screw ❷.

Screw, steering stem	
M8	20 Nm (14.8 ft·lb _f)

- Tighten screws ❶.





Screw, top triple clamp	
M8	20 Nm (14.8 ft·lb _f)

Reworking

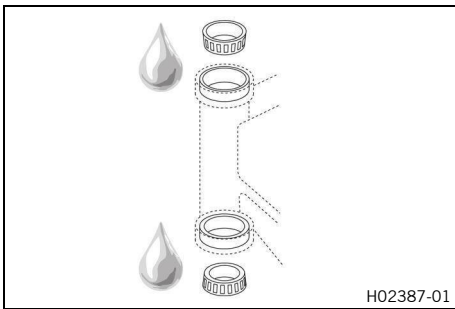
- Check the steering head bearing play. 📖 (p. 54)
- Remove the motorcycle from the lift stand. 📖 (p. 47)

13.13 Lubricating the steering head bearing



- Remove the lower triple clamp.   (p. 51)
- Install the lower triple clamp.   (p. 52)



Note

The steering head bearing is cleaned and lubricated in the course of removal and installation of the lower triple clamp.

13.14 Removing the number plate

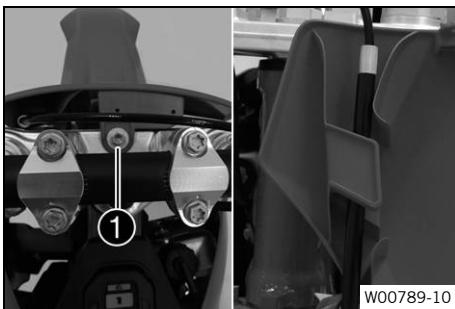

- Remove screw **1**.
- Unhook the number plate from the brake line and remove it.

13.15 Mounting the number plate



- Attach the start number plate to the brake line.
- Position the number plate.
- ✓ Holding lugs **1** engage in the fender.

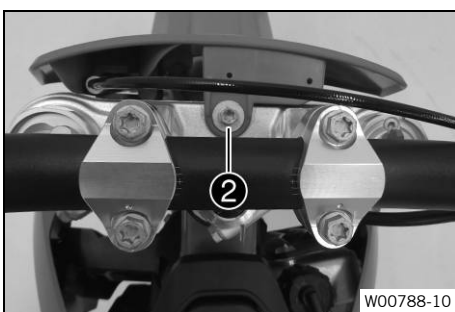

- Mount and tighten screw **2**.

Start number plate screw	
M6	4 Nm (3.0 ft·lb _f)

13.16 Removing the front top fender

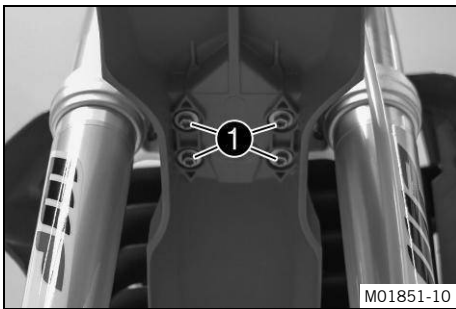

- Remove ① screws.
- Remove the front fender.

13.17 Installing the front top fender

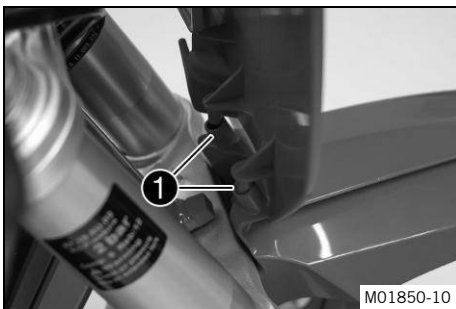

- Position the fender with drill holes ① in the holding lugs on the start number plate.

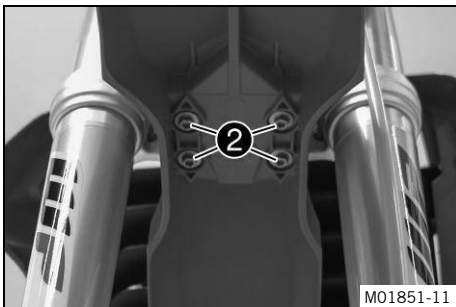

- Position the front fender.
- Mount and tighten screws ②.

Fender screw	
M6	6 Nm (4.4 ft·lb _r)

13.18 Removing the shock absorber

Preparatory work

- Raise the motorcycle with a lift stand. 📖 (p. 47)
- Remove the right side panel. 📖 (p. 60)

Main work

- Note the installation position of the shock absorber.
- Pull brake line ① out of the holder.
- Remove screw ② and lower the link fork carefully.
- Remove screw ③, push splash protector ④ to the side, and remove the shock absorber.

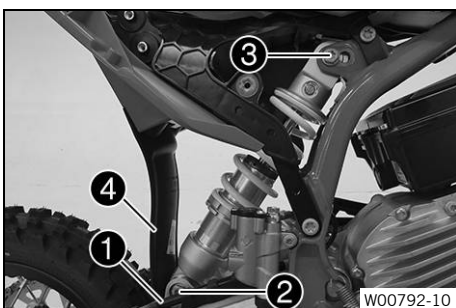

13.19 Installing the shock absorber



WARNING

Danger of accidents Modifications to the suspension settings that are not properly coordinated can impair the handling and overload components.

- Only make adjustments within the recommended range.
- Make sure your child rides slowly to start with after making adjustments in order that he or she can assess the new handling characteristic.

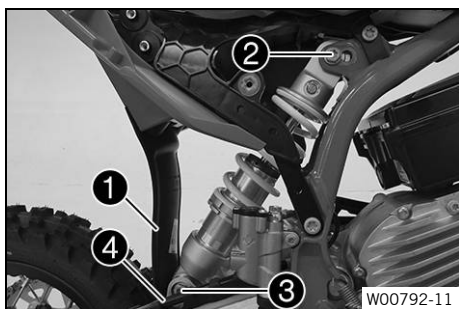

Main work

- Push splash protector **1** to the side.
- Mount the shock absorber with screw **2**.

If necessary, observe the installation position noted during removal.

Top shock absorber screw

M10×42	45 Nm (33.2 ft·lb _f)
Loctite® 243	

- Lift the link fork, mount screw **3** and tighten it.

Bottom shock absorber screw

M10×52	45 Nm (33.2 ft·lb _f)
Loctite® 243	

- Attach brake line **4** to the holder.

Reworking

- Install the right side panel. (p. 61)
- Remove the motorcycle from the lift stand. (p. 47)

13.20 Checking the rubber buffer and pivot points of the shock absorber

Condition: Shock absorber is removed

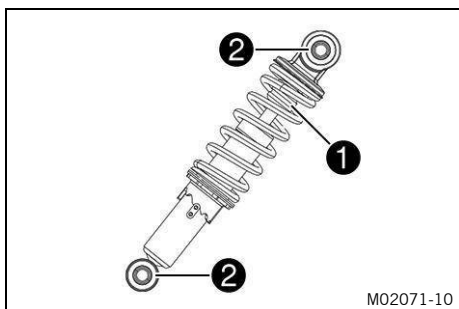

- Check rubber buffer **1** and pivot points **2** of the shock absorber for damage and wear.
 - » If there is damage or wear:
 - Change shock absorber.

13.21 Removing the seat

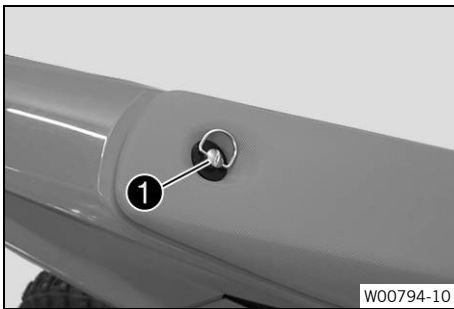

- Open quick release ① and raise the rear of the seat.
- Pull back the seat and remove it.



13.22 Mounting the seat

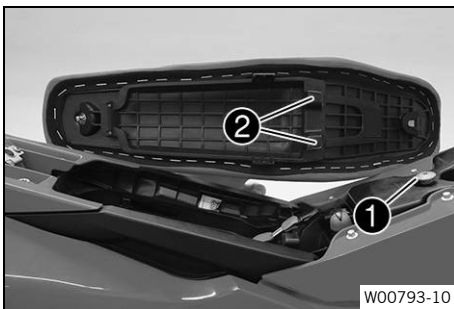

- Hook the seat onto the holding lug ①, then lower it at the rear and push it forward.
- ✓ The holding lugs ② engage with the storage compartment.



- Close quick release ③.



13.23 Removing the left side panel

Condition: Side panel secured

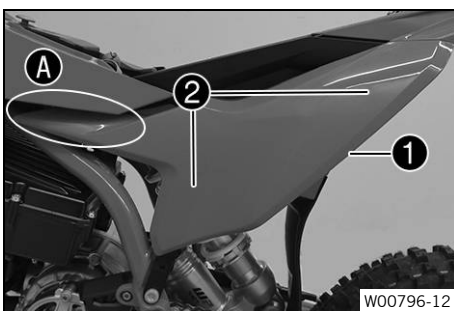

- Loosen screw ①.
- Pull the side panel out of the rubber bushings in areas ②.

Pay attention to area A.

- Remove the side panel.

Condition: Side panel not secured

13 Service work on the chassis

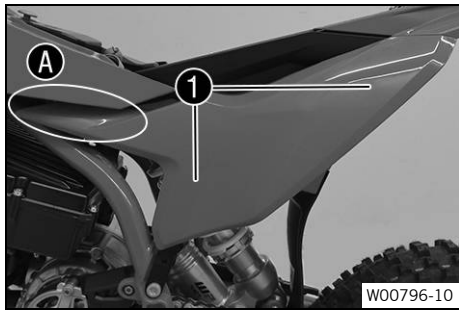

- Pull the side panel out of the rubber bushings in areas 1.
- | |
|--------------------------|
| Pay attention to area A. |
|--------------------------|
- Remove the side panel.

13.24 Installing the left side panel

Condition: Side panel secured

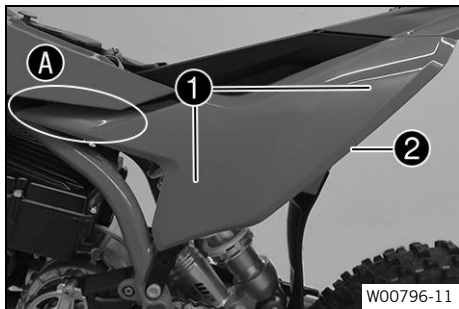

- Position the side panel in area A.
- Press side panel in areas 1 into the rubber bushings.
- Mount and tighten screw 2.

Remaining screws on chassis	
-----------------------------	--

EJOT PT® – K50×18	2 Nm (1.5 ft·lb _f)
-------------------	-----------------------------------

Condition: Side panel not secured

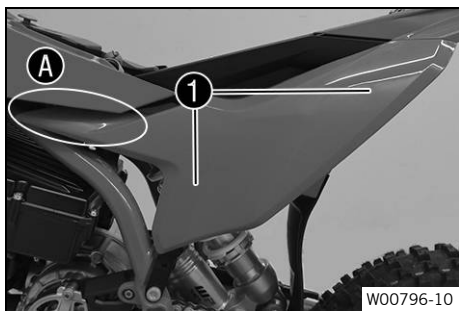

- Attach the side cover in area A.
- Press side panel in areas 1 into the rubber bushings.

13.25 Removing the right side panel

Condition: Side panel secured

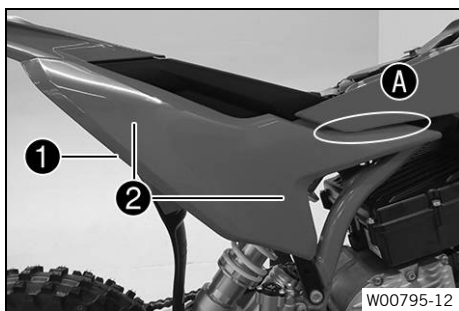

- Loosen screw 1.
 - Pull the side panel out of the rubber bushings in areas 2.
- | |
|--------------------------|
| Pay attention to area A. |
|--------------------------|
- Remove the side panel.

Condition: Side panel not secured

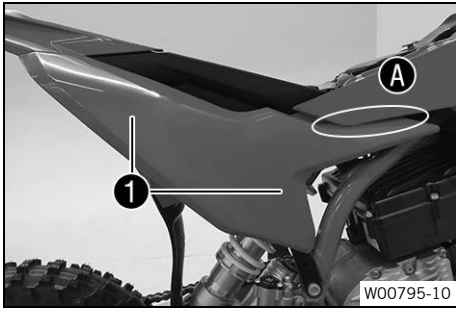

- Pull the side panel out of the rubber bushings in areas **1**.
- | |
|----------------------------------|
| Pay attention to area A . |
|----------------------------------|
- Remove the side panel.

13.26 Installing the right side panel

Condition: Side panel secured

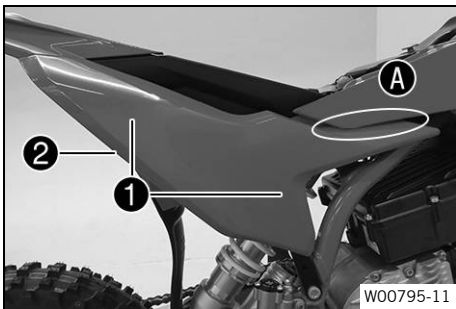

- Position the side panel in area **A**
- Press side panel in areas **1** into the rubber bushings.
- Mount and tighten screw **2**.

Remaining screws on chassis

EJOT PT® – K50×18	2 Nm (1.5 ft·lb _f)
--------------------------	-----------------------------------

Condition: Side panel not secured



- Attach the side cover in area **A**.
- Press side panel in areas **1** into the rubber bushings.

13.27 Securing the side panel

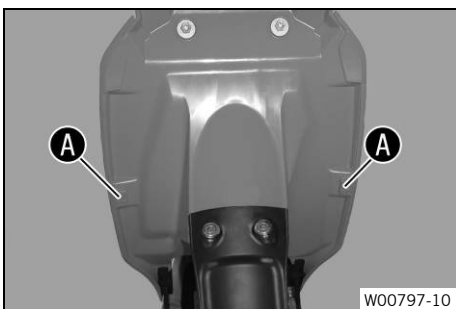

- Drill a hole at marks **A**.

Diameter	6 mm (0.24 in)
----------	-------------------

13.28 Checking the chain for dirt

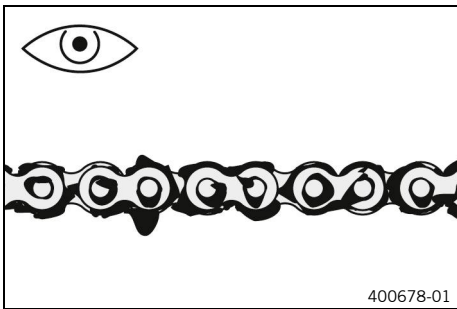

- Check the chain for coarse dirt accumulation.
 - » If the chain is very dirty:
 - Clean the chain. 📖 (p. 62)

13.29 Cleaning the chain



WARNING

Danger of accidents Oil, grease or wax on the brake discs reduces the brake action.

- Always keep the brake discs free of oil, fat and wax.
- Clean the brake discs with brake cleaner when necessary.



WARNING

Danger of accidents Lubricants on the tires reduces the road grip.

- Remove lubricants from the tires using a suitable cleaning agent.



NOTE

Environmental hazard Hazardous substances cause environmental damage.

- Dispose of oils, grease, cleaning agents, brake fluid etc. properly and in compliance with the applicable regulations.



Note

The service life of the chain depends largely on its maintenance.

Preparatory work

- Raise the motorcycle with a lift stand. 📖 (p. 47)

Main work

- Rinse off the loose dirt with a gentle jet of water.

Do not remove the bearing bridge of the engine sprocket.

- Remove old grease residues with a chain cleaner.

Chain cleaner 📖 (p. 116)

- After drying, apply chain spray.

Off-road chain spray 📖 (p. 114)

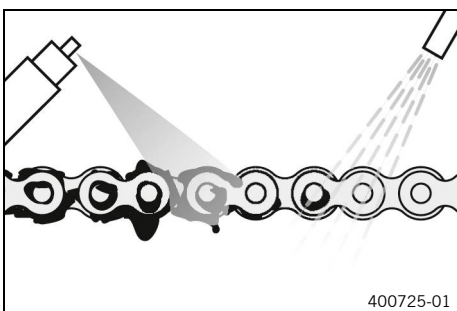

Reworking

- Remove the motorcycle from the lift stand. 📖 (p. 47)

13.30 Checking the chain tension



WARNING

Danger of accidents Incorrect chain tension can damage components and result in an accident.

If the chain tension is too high, the chain, front sprocket, rear sprocket, transmission, and rear wheel bearings wear more quickly. Some components may break if overloaded.

If the chain is too loose, the chain may fall off the front sprocket or the rear sprocket. This can damage the rear wheel or the engine.

- Check the chain tension regularly.
- Set the chain tension in accordance with the specification.

Preparatory work

- Raise the motorcycle with a lift stand. (p. 47)

Main work

- Press the chain upward at the end of the chain slider and determine chain tension **A**.

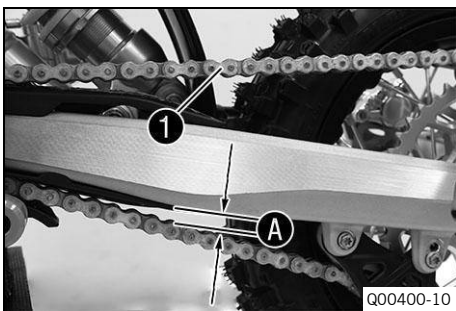

Chain tension	5 mm ... 8 mm (0.20 in ... 0.31 in)
The top part of chain 1 must be taut.	
Chain wear is not always even, so repeat this measurement at different positions on the chain.	

- » If the chain tension does not meet the specification:
 - Adjust the chain tension. (p. 63)

Reworking

- Remove the motorcycle from the lift stand. (p. 47)



13.31 Adjusting the chain tension



WARNING

Danger of accidents Incorrect chain tension can damage components and result in an accident.

If the chain tension is too high, the chain, front sprocket, rear sprocket, transmission, and rear wheel bearings wear more quickly. Some components may break if overloaded.

If the chain is too loose, the chain may fall off the front sprocket or the rear sprocket. This can damage the rear wheel or the engine.

- Check the chain tension regularly.
- Set the chain tension in accordance with the specification.

Preparatory work

- Raise the motorcycle with a lift stand. (p. 47)
- Check the chain tension. (p. 63)

13 Service work on the chassis

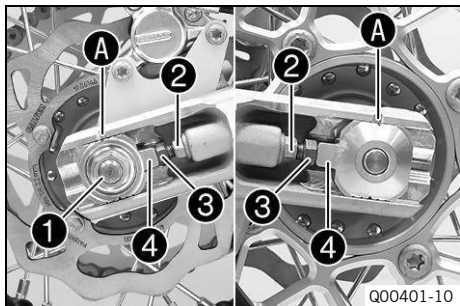

Main work

- Loosen nut ①.
- Loosen nuts ②.
- Adjust the chain tension by turning adjusting screws ③ on the left and right.

Chain tension	5 mm ... 8 mm (0.20 in ... 0.31 in)
---------------	--

In order for the rear wheel to be correctly aligned, the markings on the left and right chain adjusters must be in the same position relative to reference markings A.

- Hand-tighten nut ②.
- Make sure that chain tension adjusters ④ are fitted correctly on adjusting screws ③.
- Tighten nut ①.

Nut, wheel spindle, rear	
M12×1	70 Nm (51.6 ft·lb _f)

Reworking

- Remove the motorcycle from the lift stand. 📖 (p. 47)

13.32 Checking the chain, rear sprocket, front sprocket, and chain guide

Preparatory work

- Raise the motorcycle with a lift stand. 📖 (p. 47)

Main work

- Check the chain, rear sprocket, and front sprocket for wear.
 - » If the chain, rear sprocket, or front sprocket is worn:
 - Change the drivetrain kit. 🔧

Always replace the front sprocket, rear sprocket, and chain together.

When fitting the chain joint, always make sure that the closed side of the joint faces forward (direction of travel).

- Check the chain for wear.
 - » If the chain is worn:
 - Change the drivetrain kit. 🔧

When installing a new chain, also replace the rear sprocket and front sprocket.

i Note
New chains wear out faster on old, worn sprockets.

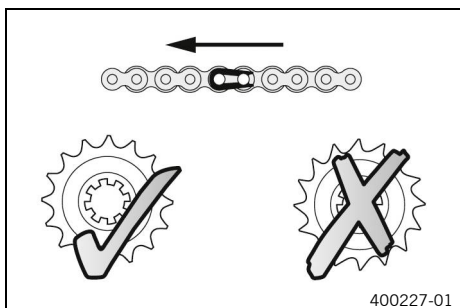

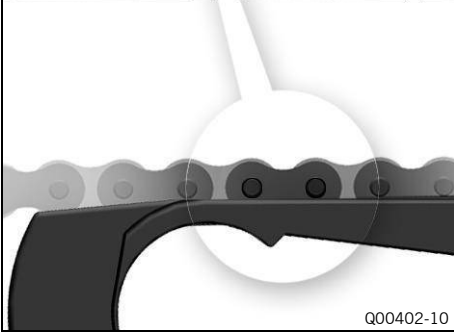
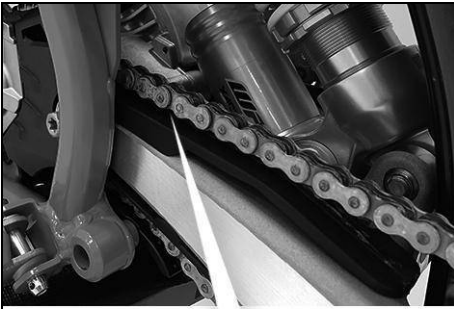



Q00402-10

- Check the chain slider at the top for wear.
 - » If the ridge is worn down to the level of the main corpus:
 - Change the chain slider. 
- Check that the chain slider is firmly seated.
 - » If the chain slider is loose:
 - Tighten the screw of the chain sliding guard.

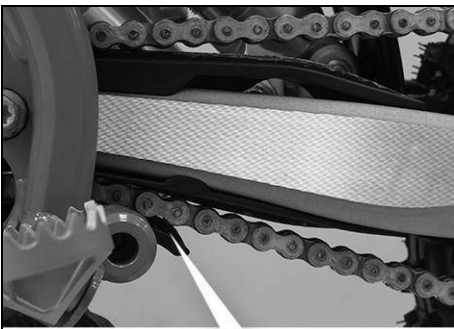
Screw, chain slider guard	
M6	3 Nm (2.2 ft·lb _f)



M01692-10

- Check the chain slider for wear.
 - » If the lower edge of the chain pins is in line with or below the chain slider:
 - Change the chain slider. 
- Check that the chain slider is firmly seated.
 - » If the chain slider is loose:
 - Tighten the screws of the chain slider.

Screw, chain slider	
M8	15 Nm (11.1 ft·lb _f)

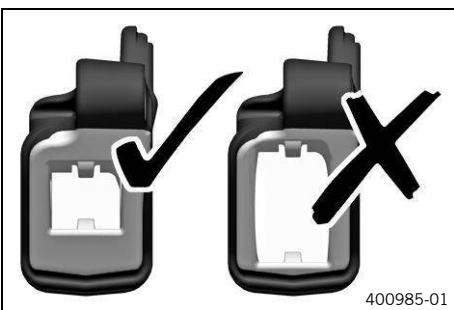

400985-01

- Check the chain guide for wear.



Note

Wear can be seen on the front of the chain guide.

- » If the light part of the chain guide is worn:
 - Change the chain guide. 

13 Service work on the chassis

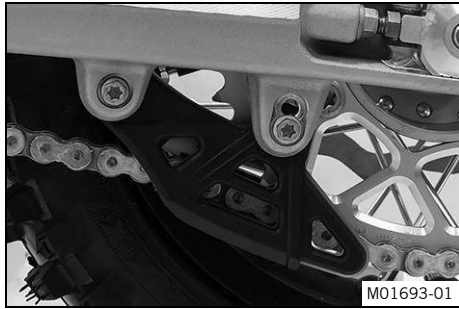

- Check that the chain guide is firmly seated.
 - » If the chain guide is loose:
 - Tighten the screws on the chain guide.

Remaining screws on chassis	
M6	10 Nm (7.4 ft·lb _r)

Reworking

- Remove the motorcycle from the lift stand. (p. 47)

13.33 Adjusting the chain guide

Note

The size of the chain wheel varies with the number of teeth. The chain guide can be adjusted on small sprockets.

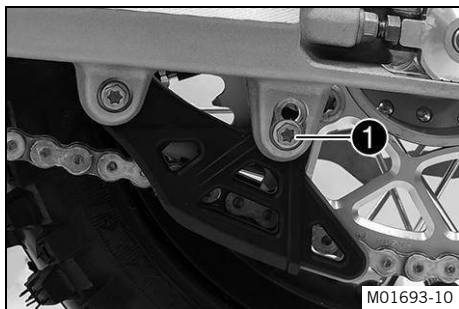

- Remove screw **1**.
- Position the chain guide.
- Mount and tighten the screw.

Remaining screws on chassis	
M6	10 Nm (7.4 ft·lb _r)

13.34 Checking the frame

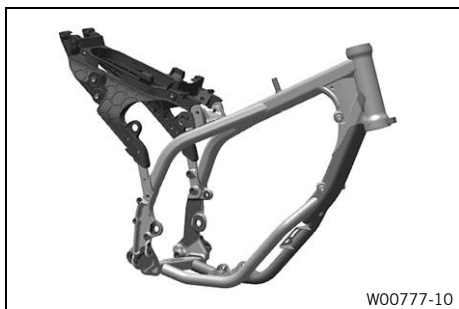

- Check the frame for damage, cracks, and deformation.
 - » If the frame shows signs of damage, cracks, or deformation:
 - Change the frame.

Repairs on the frame are not permitted.

13.35 Checking the swingarm



- Check the swingarm for damage, cracks, and deformation.
 - » If the swingarm shows signs of damage, cracks, or deformation:
 - Change the swingarm. 

Repairs on the swingarm are not permitted.

13.36 Checking the hand grip

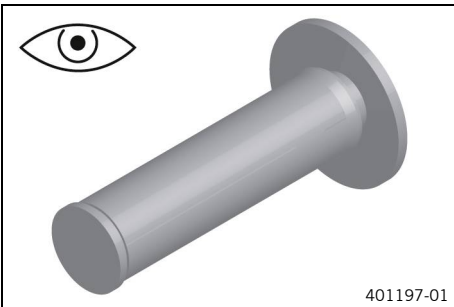

- Check the hand grips on the handlebar for damage, wear, and that they are firmly seated.

The hand grip can only be replaced with the sleeve or the gas pipe.

i Note
The hand grips are vulcanized onto a sleeve on the left and onto the grip tube of the throttle grip on the right. The left sleeve is clamped onto the handlebar.

- » If a hand grip is damaged or worn:
 - Replace the hand grip.

- Check that screw **1** is firmly seated.

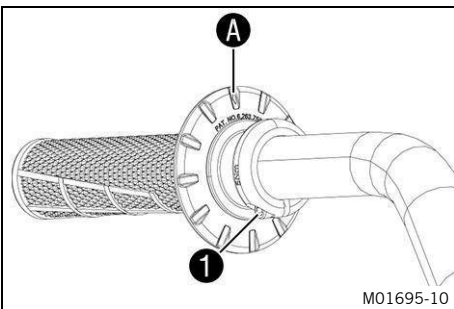

Screw, fixed grip

M4	5 Nm (3.7 ft·lb _r)
----	-----------------------------------

Diamond **A** must be located at the top.

14.1 Checking the free travel of the hand brake lever



WARNING

Danger of accidents The brake system fails in the event of overheating.
If there is no free travel on the brake lever, pressure builds up in the brake system.

- Set the free travel on the brake lever as specified.

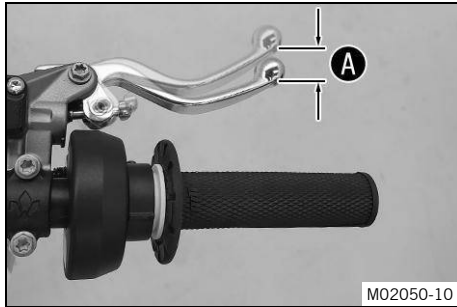

M02050-10

- Push the hand brake lever forward and check free travel **A**.

Free travel of hand brake lever	3 mm ... 5 mm (0.12 in ... 0.20 in)
---------------------------------	--

- » If the free travel does not meet the specifications:
 - Inspect the brake system for damage and dirt.

14.2 Adjusting the basic position of the hand brake lever

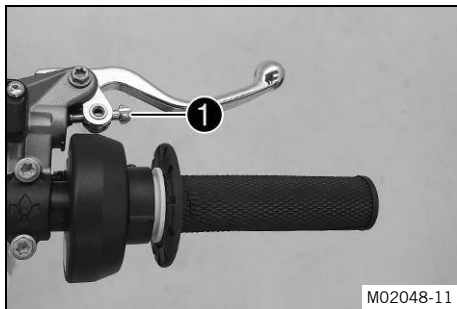

M02048-11

- Adjust the basic position of the hand brake lever with adjusting screw **1** to the rider's hand size.

i Note

Turn the adjusting screw clockwise to increase the distance between the hand brake lever and the handlebar.

Turn the adjusting screw counterclockwise to decrease the distance between the hand brake lever and the handlebar.

The range of adjustment is limited.

14.3 Checking the brake discs



WARNING

Danger of accidents Worn-out brake discs reduce the braking action.

- Make sure that worn-out brake discs are replaced immediately.

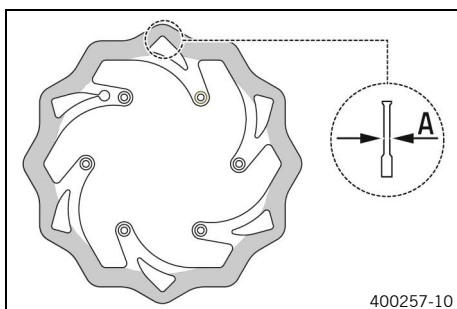





400257-10

- Check the brake disc thickness of the front and rear brake disc at several places on the disc to see if they conform to measurement **A**.

Brake disc wear limit	
front	2.2 mm (0.087 in)
rear	2.2 mm (0.087 in)

i Note
Wear reduces the thickness of the brake discs at the contact surface of the brake pads.

- » If the brake disc thickness is less than the specified value:
 - Change the brake discs of the front brake. 
 - Change the brake discs on the rear brake. 
- Check the front and rear brake discs for damage, cracks, and deformation.
 - » If the brake disc shows signs of damage, cracks, or deformation:
 - Change the brake discs of the front brake. 
 - Change the brake discs on the rear brake. 



14.4 Checking the brake fluid level for the front brake



WARNING

Danger of accidents Brake fluid which is too old or of the wrong type impairs the function of the brake system.

- Make sure that brake fluid for the front and rear brake is changed in accordance with the service schedule.
- Make sure that only clean, approved brake fluid from a tightly sealed container is used.



WARNING

Danger of accidents An insufficient brake fluid level will cause the brake system to fail.

If the brake fluid level drops below the specified marking or the specified value, the brake system has a leak or the brake pads are worn down.

- Have the brake system checked and make sure that the problem has been eliminated before the vehicle is used again.



WARNING

Health hazard Brake fluid is a harmful substance.

- Keep brake fluid out of the reach of children.
- Wear suitable protective clothing and safety glasses.
- Do not allow brake fluid to come into contact with the skin, the eyes, or clothing.
- Consult a doctor immediately if brake fluid has been ingested.
- Rinse the affected area with plenty of water in the event of contact with the skin.
- Rinse eyes thoroughly with water immediately and consult a doctor if brake fluid comes into contact with the eyes.
- If brake fluid spills on to your clothing, change the clothing.



NOTE

Environmental hazard Hazardous substances cause environmental damage.

- Dispose of oils, grease, cleaning agents, brake fluid etc. properly and in compliance with the applicable regulations.

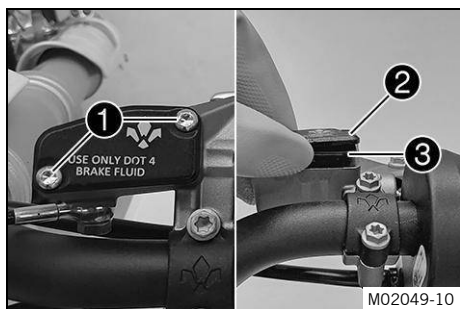

- Move the brake reservoir mounted on the handlebar to a horizontal position.
- Remove screws ①.
- Take off cover ② with membrane ③.

Avoid contact between brake fluid and painted parts. Brake fluid corrodes paint.

- Check the brake fluid level.

Brake fluid level below reservoir rim	4 mm (0.16 in)
---------------------------------------	-------------------

- » If the brake fluid level does not meet specifications:
 - Add brake fluid for the front brake. (p. 70)

- Position cover ② with membrane ③.
- Mount screws ① and screw in hand-tight.

Immediately clean up any brake fluid that has overflowed or spilled with water.

14.5 Adding brake fluid for the front brake



WARNING

Danger of accidents Brake fluid which is too old or of the wrong type impairs the function of the brake system.

- Make sure that brake fluid for the front and rear brake is changed in accordance with the service schedule.
- Make sure that only clean, approved brake fluid from a tightly sealed container is used.



WARNING

Danger of accidents An insufficient brake fluid level will cause the brake system to fail.

If the brake fluid level drops below the specified marking or the specified value, the brake system has a leak or the brake pads are worn down.

- Have the brake system checked and make sure that the problem has been eliminated before the vehicle is used again.



WARNING

Health hazard Brake fluid is a harmful substance.

- Keep brake fluid out of the reach of children.
- Wear suitable protective clothing and safety glasses.
- Do not allow brake fluid to come into contact with the skin, the eyes, or clothing.
- Consult a doctor immediately if brake fluid has been ingested.
- Rinse the affected area with plenty of water in the event of contact with the skin.
- Rinse eyes thoroughly with water immediately and consult a doctor if brake fluid comes into contact with the eyes.
- If brake fluid spills on to your clothing, change the clothing.



NOTE

Environmental hazard Hazardous substances cause environmental damage.

- Dispose of oils, grease, cleaning agents, brake fluid etc. properly and in compliance with the applicable regulations.

Preparatory work

- Check that the brake pads of the front brake are secured.  (p. 71)

Main work

- Move the brake reservoir mounted on the handlebar to a horizontal position.
- Remove screws ①.
- Take off cover ② with membrane ③.

Avoid contact between brake fluid and painted parts. Brake fluid corrodes paint.

- Correct the brake fluid level.

Brake fluid level below reservoir rim	4 mm (0.16 in)
---------------------------------------	-------------------

Brake fluid DOT 5.1  (p. 114)

- Position cover ② with membrane ③.
- Mount screws ① and screw in hand-tight.

Immediately clean up any brake fluid that has overflowed or spilled with water.

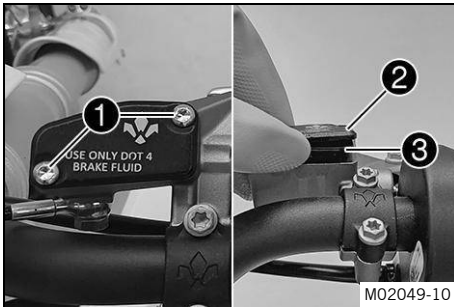

14.6 Checking that the brake pads of the front brake are secured



WARNING



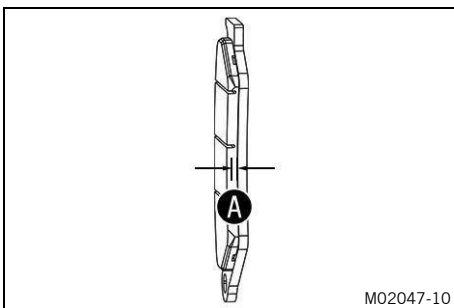

Danger of accidents Worn brake pads reduce the brake action.

- Make sure that worn brake pads are replaced immediately.



- Check all brake pads on both brake calipers for their lining thickness **A**.

Minimum pad thickness A	≥ 1 mm (≥ 0.04 in)
--------------------------------	----------------------------------

- » If it is less than the minimum thickness:
 - Change the front brake pads.   (p. 72)
- Check the brake linings for damage and cracking.
 - » If there is damage or cracking:
 - Change the front brake pads.   (p. 72)
- Check that the brake pads are secured.
 - » If the brake pads are not secured correctly:
 - Secure brake pads, replace with new parts if necessary.

14.7 Changing the brake pads of the front brake



WARNING

- Danger of accidents** Brake pads which have not been approved alter the braking action.
- Only use brake pads approved and recommended by the vehicle manufacturer.



WARNING

- Danger of accidents** Incorrect servicing will cause the brake system to fail.
- Ensure that service work and repairs are performed professionally.



WARNING

- Danger of accidents** Brake fluid which is too old or of the wrong type impairs the function of the brake system.
- Make sure that brake fluid for the front and rear brake is changed in accordance with the service schedule.
 - Make sure that only clean, approved brake fluid from a tightly sealed container is used.



WARNING

- Health hazard** Brake fluid is a harmful substance.
- Keep brake fluid out of the reach of children.
 - Wear suitable protective clothing and safety glasses.
 - Do not allow brake fluid to come into contact with the skin, the eyes, or clothing.
 - Consult a doctor immediately if brake fluid has been ingested.
 - Rinse the affected area with plenty of water in the event of contact with the skin.
 - Rinse eyes thoroughly with water immediately and consult a doctor if brake fluid comes into contact with the eyes.
 - If brake fluid spills on to your clothing, change the clothing.



NOTE

- Environmental hazard** Hazardous substances cause environmental damage.
- Dispose of oils, grease, cleaning agents, brake fluid etc. properly and in compliance with the applicable regulations.

Preparatory work

- Raise the motorcycle with a lift stand.  (p. 47)

Main work

- Move the brake reservoir mounted on the handlebar to a horizontal position.
- Remove screws **1**.
- Take off cover **2** with membrane **3**.

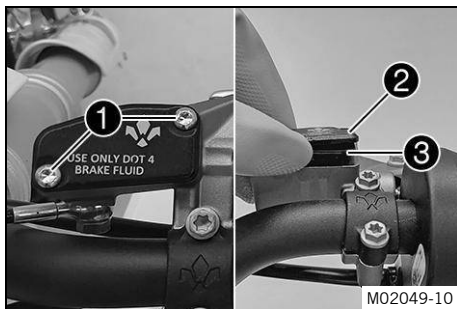

Avoid contact between brake fluid and painted parts. Brake fluid corrodes paint.

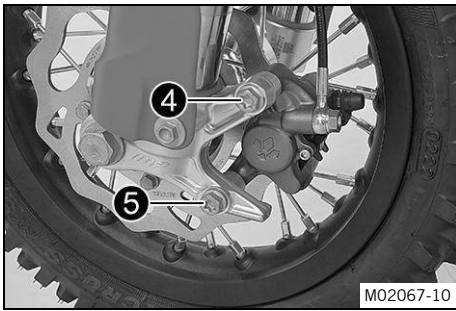

- Remove screws 4 and 5.
- Press the brake pads back by slightly tilting the brake caliper laterally on the brake disc.
- Carefully pull the brake caliper backward from the brake disc.
- Press the brake piston back into the basic position and ensure that no brake fluid overflows from the brake reservoir, siphon off if necessary.

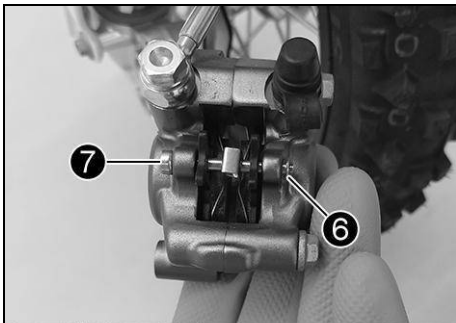

- Remove lock ring 6.
- Remove screw 7.
- Remove the brake pads.
- Clean brake caliper and brake caliper support.
- Put the new brake pads in position.

Ensure that the brake pads are correctly positioned in the retaining spring.

Always replace brake pads in sets.

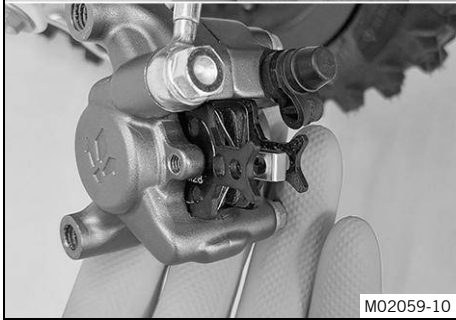

- Mount and tighten screw 7.

Screw, brake linings

M5	8 Nm (5.9 ft·lb _r)
----	-----------------------------------

- Mount lock ring 6.



WARNING

Danger of accidents Oil, grease or wax on the brake discs reduces the brake action.

- Always keep the brake discs free of oil, fat and wax.
- Clean the brake discs with brake cleaner when necessary.

- Check the brake discs. (p. 68)
- Position the brake caliper, mount screw 4, and tighten.

Screw, front brake caliper

M8×35	20 Nm (14.8 ft·lb _r) Loctite® 243
-------	--

- Mount and tighten screw 5.

Screw, front brake caliper

M8×35	20 Nm (14.8 ft·lb _r) Loctite® 243
-------	--

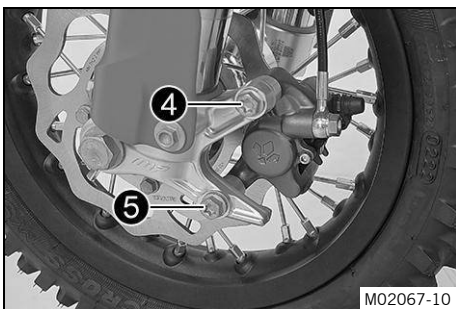

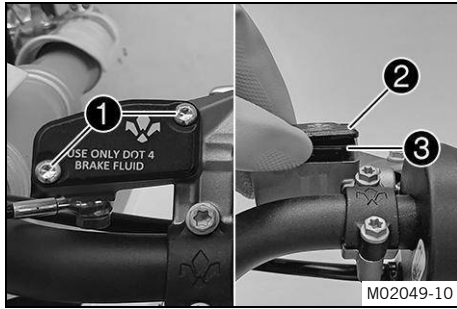

- Check the brake fluid level and correct if necessary.

Brake fluid level below reservoir rim	4 mm (0.16 in)
---------------------------------------	-------------------

Brake fluid DOT 5.1 (p. 114)

- Position cover ② with membrane ③.
- Mount screw ① and screw in hand-tight.

Immediately clean up any brake fluid that has overflowed or spilled with water.

Reworking

- Remove the motorcycle from the lift stand. (p. 47)

14.8 Checking the free travel of the brake pedal



WARNING

Danger of accidents The brake system fails in the event of overheating.

If there is no free travel on the brake lever, pressure builds up in the brake system.

- Set the free travel on the brake lever as specified.

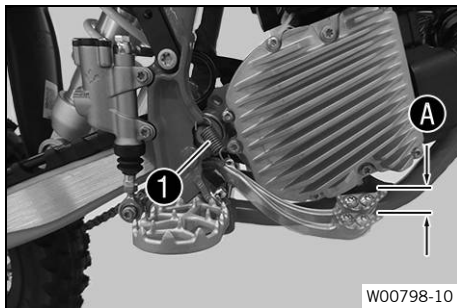

- Detach spring ①.
- Move the foot brake lever back and forth between the end stop and the contact to the foot brake cylinder piston and check free travel ①.

Free travel of brake pedal	3 mm ... 5 mm (0.12 in ... 0.20 in)
----------------------------	--

» If the free travel does not meet the specifications:

- Adjust the free travel of the foot brake lever. (p. 74)

- Attach spring ①.

14.9 Adjusting the free travel of the foot brake lever



WARNING

Danger of accidents The brake system fails in the event of overheating.

If there is no free travel on the brake lever, pressure builds up in the brake system.

- Set the free travel on the brake lever as specified.

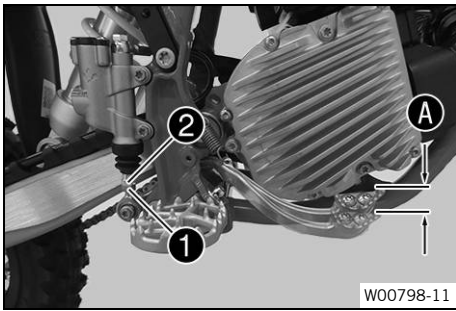



- Detach the brake pedal spring.
- Loosen nut 1.
- Turn push rod 2 accordingly until you have free travel A.

Free travel of brake pedal	3 mm ... 5 mm (0.12 in ... 0.20 in)
----------------------------	--

- Hold push rod 2 and tighten nut 1.

Remaining nuts on chassis	
M6	10 Nm (7.4 ft·lb _f)

- Attach the brake pedal spring.
- Check whether the basic position of the brake pedal is suitable for the rider.
 - » When the basic position of the brake pedal needs to be adjusted:
 - Adjust the basic position of the brake pedal. 
 -  (p. 75)



14.10 Adjusting the basic position of the brake pedal



WARNING

Danger of accidents The brake system fails in the event of overheating.
If there is no free travel on the brake lever, pressure builds up in the brake system.

- Set the free travel on the brake lever as specified.

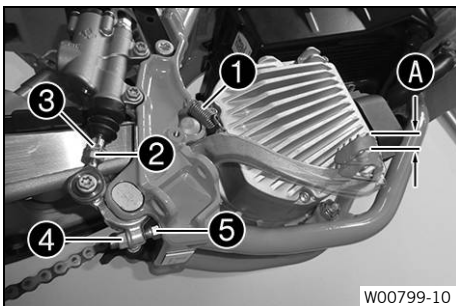

- Detach spring 1.
- Loosen nut 2 and unscrew it with push rod 3 until you have maximum free travel.
- For an individual adjustment of the basic position of the brake pedal, loosen the nut 4 and turn the eccentric brake pedal stop 5 accordingly.



Note

The range of adjustment is limited.

- Turn push rod 3 accordingly until you have free travel A.

Free travel of brake pedal	3 mm ... 5 mm (0.12 in ... 0.20 in)
----------------------------	--

- Hold screw 5 and tighten nut 4.

Remaining nuts on chassis	
M6	10 Nm (7.4 ft·lb _f)

- Hold push rod 3 and tighten nut 2.

Remaining nuts on chassis	
M6	10 Nm (7.4 ft·lb _f)

- Attach spring ❶.
- Check the free travel of the brake pedal. 📖 (p. 74)

14.11 Checking the brake fluid level for the rear brake



WARNING

Danger of accidents Brake fluid which is too old or of the wrong type impairs the function of the brake system.

- Make sure that brake fluid for the front and rear brake is changed in accordance with the service schedule.
- Make sure that only clean, approved brake fluid from a tightly sealed container is used.



WARNING

Danger of accidents An insufficient brake fluid level will cause the brake system to fail.

If the brake fluid level drops below the specified marking or the specified value, the brake system has a leak or the brake pads are worn down.

- Have the brake system checked and make sure that the problem has been eliminated before the vehicle is used again.



WARNING

Health hazard Brake fluid is a harmful substance.

- Keep brake fluid out of the reach of children.
- Wear suitable protective clothing and safety glasses.
- Do not allow brake fluid to come into contact with the skin, the eyes, or clothing.
- Consult a doctor immediately if brake fluid has been ingested.
- Rinse the affected area with plenty of water in the event of contact with the skin.
- Rinse eyes thoroughly with water immediately and consult a doctor if brake fluid comes into contact with the eyes.
- If brake fluid spills on to your clothing, change the clothing.



NOTE

Environmental hazard Hazardous substances cause environmental damage.

- Dispose of oils, grease, cleaning agents, brake fluid etc. properly and in compliance with the applicable regulations.

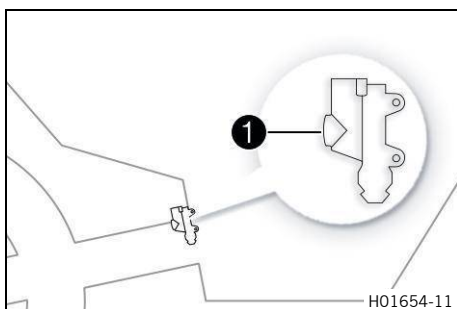

- Stand the vehicle upright.
- Check the brake fluid level in sight glass ❶.
 - » If the brake fluid level is below the **MIN** marking:
 - Add brake fluid for the rear brake. 🛠️ 📖 (p. 77)

14.12 Adding brake fluid for the rear brake



WARNING

Danger of accidents Brake fluid which is too old or of the wrong type impairs the function of the brake system.

- Make sure that brake fluid for the front and rear brake is changed in accordance with the service schedule.
- Make sure that only clean, approved brake fluid from a tightly sealed container is used.



WARNING

Danger of accidents An insufficient brake fluid level will cause the brake system to fail.

If the brake fluid level drops below the specified marking or the specified value, the brake system has a leak or the brake pads are worn down.

- Have the brake system checked and make sure that the problem has been eliminated before the vehicle is used again.



WARNING

Health hazard Brake fluid is a harmful substance.

- Keep brake fluid out of the reach of children.
- Wear suitable protective clothing and safety glasses.
- Do not allow brake fluid to come into contact with the skin, the eyes, or clothing.
- Consult a doctor immediately if brake fluid has been ingested.
- Rinse the affected area with plenty of water in the event of contact with the skin.
- Rinse eyes thoroughly with water immediately and consult a doctor if brake fluid comes into contact with the eyes.
- If brake fluid spills on to your clothing, change the clothing.





NOTE

Environmental hazard Hazardous substances cause environmental damage.

- Dispose of oils, grease, cleaning agents, brake fluid etc. properly and in compliance with the applicable regulations.

Preparatory work

- Raise the motorcycle with a lift stand.  (p. 47)
- Check that the brake pads of the rear brake are secured.  (p. 78)

Main work

- Remove screws **1**.
- Take off cover **2** with washer **3** and membrane **4**.

Avoid contact between brake fluid and painted parts. Brake fluid corrodes paint.

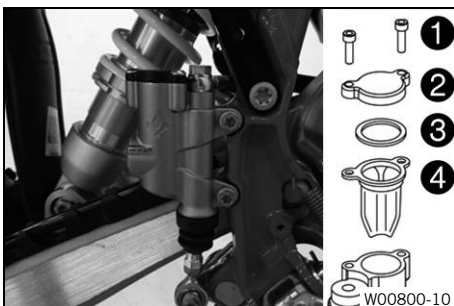

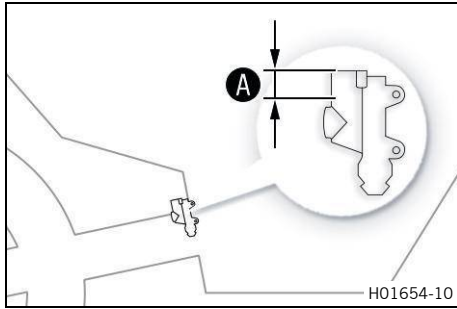

- Add brake fluid up to level **A**.

Level A (brake fluid level below reservoir rim)	10 mm (0.39 in)
--	--------------------

Brake fluid DOT 5.1 (p. 114)

- Position cover **2** with washer **3** and diaphragm **4**.
- Mount screws **1** and screw in hand-tight.

Immediately clean up any brake fluid that has overflowed or spilled with water.

Reworking

- Remove the motorcycle from the lift stand. (p. 47)

14.13 Checking that the brake pads of the rear brake are secured



WARNING

Danger of accidents Worn brake pads reduce the brake action.

- Make sure that worn brake pads are replaced immediately.

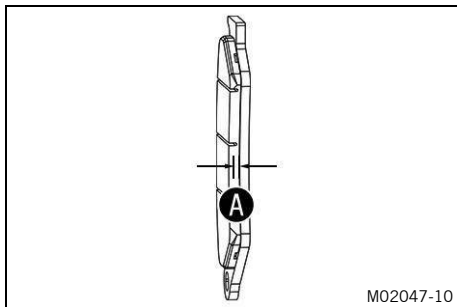

- Check all brake pads on both brake calipers for their lining thickness **A**.

Minimum pad thickness A	≥ 1 mm (≥ 0.04 in)
--------------------------------	----------------------------------

- » If the minimum thickness is less than specified:
 - Change the rear brake pads. (p. 78)
- Check the brake linings for damage and cracking.
 - » If damage or wear is encountered:
 - Change the rear brake pads. (p. 78)
- Check that the brake pads are secured.
 - » If the brake pads are not secured correctly:
 - Secure brake pads, replace with new parts if necessary.

14.14 Changing the rear brake pads



WARNING

Danger of accidents Brake pads which have not been approved alter the braking action.

- Only use brake pads approved and recommended by the vehicle manufacturer.



WARNING

Danger of accidents Incorrect servicing will cause the brake system to fail.

- Ensure that service work and repairs are performed professionally.



WARNING

Danger of accidents Brake fluid which is too old or of the wrong type impairs the function of the brake system.

- Make sure that brake fluid for the front and rear brake is changed in accordance with the service schedule.
- Make sure that only clean, approved brake fluid from a tightly sealed container is used.



WARNING

Danger of accidents Oil, grease or wax on the brake discs reduces the brake action.

- Always keep the brake discs free of oil, fat and wax.
- Clean the brake discs with brake cleaner when necessary.



WARNING

Health hazard Brake fluid is a harmful substance.

- Keep brake fluid out of the reach of children.
- Wear suitable protective clothing and safety glasses.
- Do not allow brake fluid to come into contact with the skin, the eyes, or clothing.
- Consult a doctor immediately if brake fluid has been ingested.
- Rinse the affected area with plenty of water in the event of contact with the skin.
- Rinse eyes thoroughly with water immediately and consult a doctor if brake fluid comes into contact with the eyes.
- If brake fluid spills on to your clothing, change the clothing.



NOTE

Environmental hazard Hazardous substances cause environmental damage.

- Dispose of oils, grease, cleaning agents, brake fluid etc. properly and in compliance with the applicable regulations.

Preparatory work

- Raise the motorcycle with a lift stand.  (p. 47)

Main work

- Remove lock ring **1**.
- Remove screw **2**.

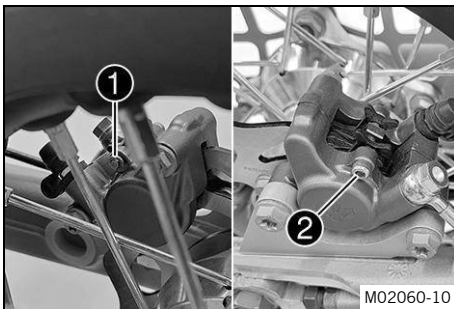

- Remove the brake pads.
- Clean brake caliper and brake caliper support.

14 Brake system

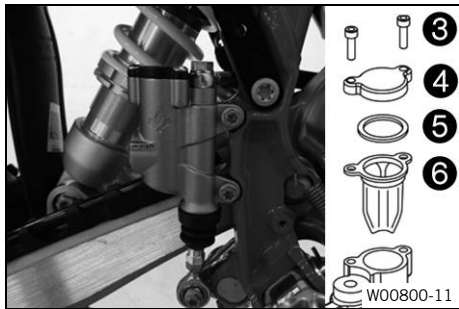

- Remove screws **3**.
- Take off cover **4** with washer **5** and membrane **6**.

Avoid contact between brake fluid and painted parts. Brake fluid corrodes paint.

- Press the brake piston back to its basic position and make sure that no brake fluid overflows from the brake reservoir, extract some brake fluid if necessary.

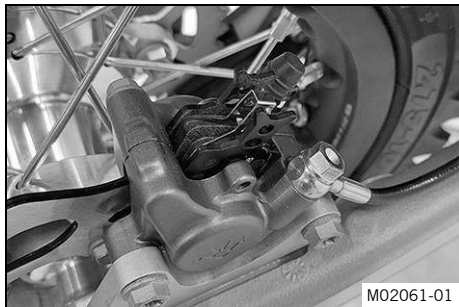

- Put the new brake pads in position.

Ensure that the brake pads are correctly positioned in the retaining spring.

Always replace brake pads in sets.

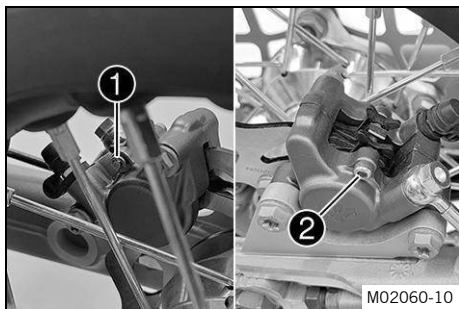

- Mount and tighten screw **2**.

Screw, brake linings	
M5	8 Nm (5.9 ft·lb _r)

- Mount lock ring **1**.

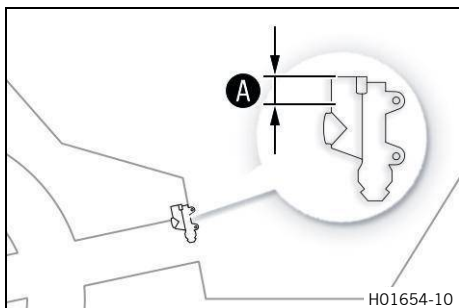

- Actuate the brake disc repeatedly until the brake pads are in contact with the brake disc and a pressure point is achieved.
- Add brake fluid up to level **A**.

Level A (brake fluid level below reservoir rim)	10 mm (0.39 in)
--	--------------------

Brake fluid DOT 5.1 (p. 114)

- Position cover **4** with washer **5** and diaphragm **6**.
- Mount screws **3** and screw in hand-tight.

Immediately clean up any brake fluid that has overflowed or spilled with water.

Reworking

- Remove the motorcycle from the lift stand. (p. 47)

15.1 Removing the front wheel

Preparatory work

- Raise the motorcycle with a lift stand.  (p. 47)

Main work

- Remove screw **1**.
- Loosen screws **2**.

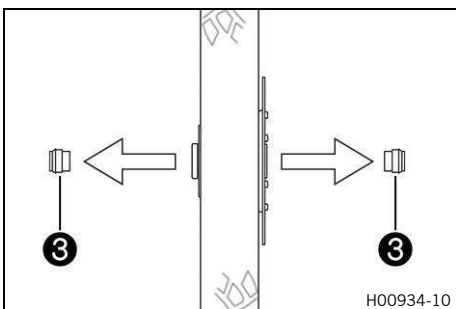
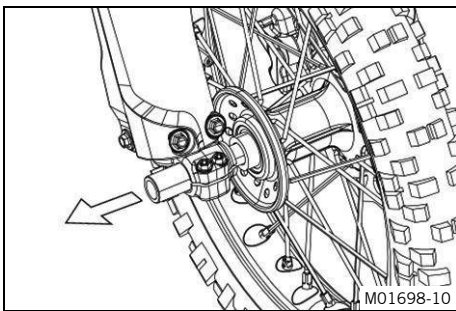
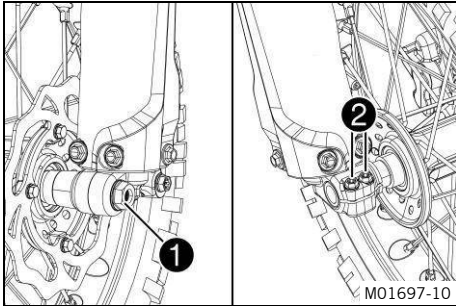

WARNING

Danger of accidents Damaged brake discs reduce the braking action.

- Always lay the wheel down in such a way that the brake disc is not damaged.

- Hold front wheel and remove wheel spindle.
- Take the front wheel out of the fork.

Do not actuate the hand brake lever when the front wheel is removed.

- Remove spacers **3**.

15.2 Installing the front wheel



WARNING

Danger of accidents Oil, grease or wax on the brake discs reduces the brake action.

- Always keep the brake discs free of oil, fat and wax.
- Clean the brake discs with brake cleaner when necessary.

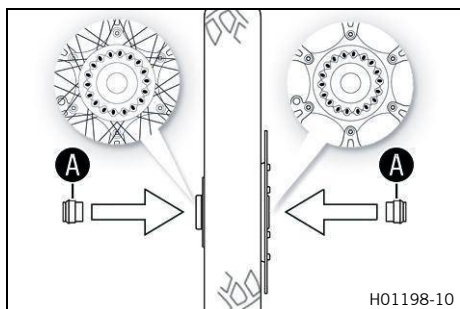

- Check the wheel bearing for damage and wear.
 - » If the wheel bearings are damaged or worn:
 - Change the front wheel bearing.
- Clean and grease the contact surfaces **A** of the spacers.

Long-life grease (p. 114)

- Insert the spacers.

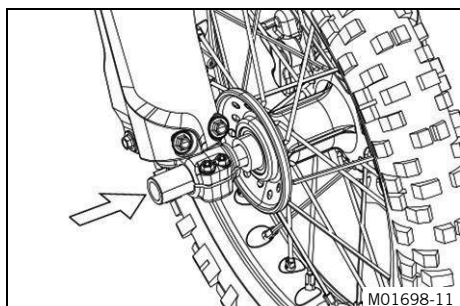

- Clean and lightly grease the wheel spindle.

Long-life grease (p. 114)

- Position the front wheel.
 - ✓ The brake pads are positioned correctly.
- Insert the wheel spindle.

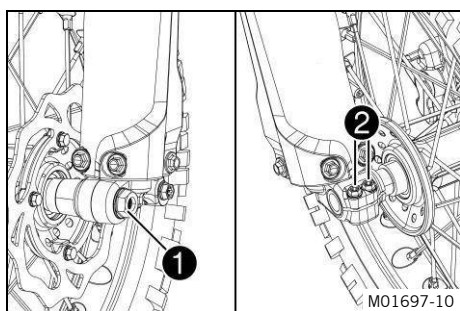

- Mount and tighten screw **1**.

Screw, wheel spindle, front

M10	40 Nm (29.5 ft·lb _f) Loctite® 243
-----	--

- Operate the hand brake lever several times until the brake pads are in contact with the brake disc.
- Remove the motorcycle from the lift stand. (p. 47)
- Operate the front brake and compress the fork a few times firmly.
 - ✓ The fork legs straighten.

- Tighten screws **2**.

Screw, fork shoe

M6	10 Nm (7.4 ft·lb _f)
----	------------------------------------

15.3 Removing the rear wheel

Preparatory work

- Raise the motorcycle with a lift stand. (p. 47)

Main work

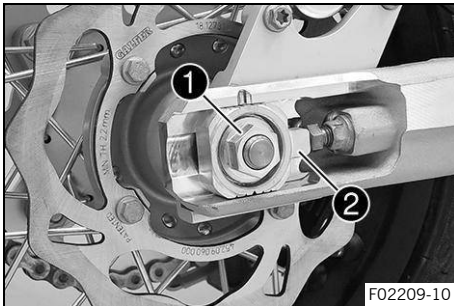

- Remove nut ①.
- Remove chain tension adjuster ②.



- Pull out wheel spindle ③ far enough to allow the rear wheel to be pushed forward.
- Push the rear wheel forward as far as possible.
- Remove the chain from the rear sprocket.

Protect the components against damage by covering them.



WARNING

Danger of accidents Damaged brake discs reduce the braking action.

- Always lay the wheel down in such a way that the brake disc is not damaged.

- Hold the rear wheel and remove wheel spindle ③.
- Take the rear wheel out of the swingarm.

Do not actuate the brake pedal when the rear wheel is removed.

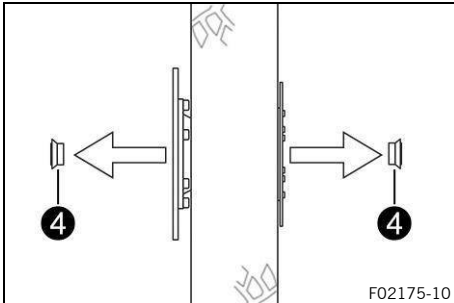

- Remove spacers ④.

15.4 Installing the rear wheel



WARNING

Danger of accidents Oil, grease or wax on the brake discs reduces the brake action.

- Always keep the brake discs free of oil, fat and wax.
- Clean the brake discs with brake cleaner when necessary.

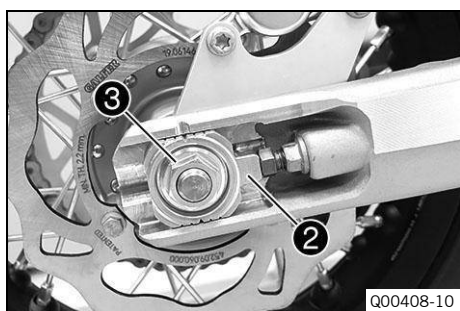
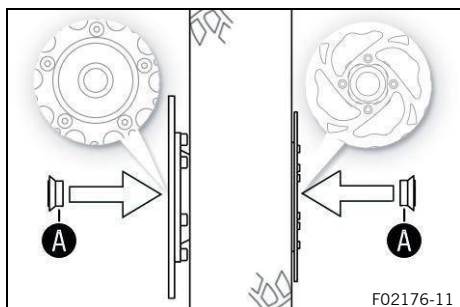

Main work

- Check the wheel bearing for damage and wear.
 - » If the wheel bearings are damaged or worn:
 - Change the rear wheel bearing.
- Clean and grease the contact surfaces **A** of the spacers.

Long-life grease (p. 114)

- Insert the spacers.

Insert the wide spacer on the left in the direction of travel.

- Clean and grease wheel spindle **1**.

Long-life grease (p. 114)

- Position the rear wheel and insert wheel spindle **1**.
 - ✓ The brake pads are positioned correctly.
- Attach the chain.
- Position chain tension adjuster **2** on both sides and push wheel spindle **1** all the way in.

- Mount nut **3** but do not tighten yet.
- Make sure that the chain tension adjusters are fitted correctly on the adjusting screws.
- Check the chain tension. (p. 63)
- Tighten nut **3**.

Nut, wheel spindle, rear

M12×1	70 Nm (51.6 ft·lb _f)
-------	-------------------------------------

- Actuate the brake pedal repeatedly until the brake pads are in contact with the brake disc and a pressure point is achieved.

Reworking

- Remove the motorcycle from the lift stand. (p. 47)

15.5 Checking the tire condition

i Note

Only mount tires approved and/or recommended by KTM. Other tires could have a negative effect on handling characteristics. The type, condition, and pressure of the tires all have a major impact on the handling of the motorcycle. The tires mounted on the front and rear wheels must have a similar profile. Worn tires have a negative effect on handling characteristics, especially on wet surfaces.

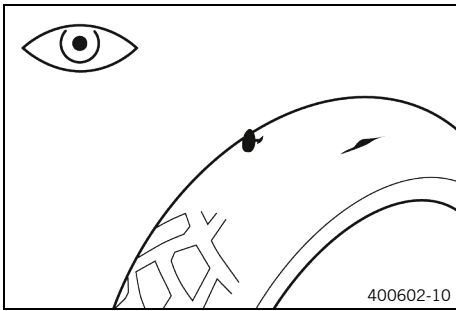

- Check the front and rear tires for cuts, embedded objects, and other damage.
 - » If the tires have cuts, run-in objects, or other damage:
 - Change the tires. 🛠️

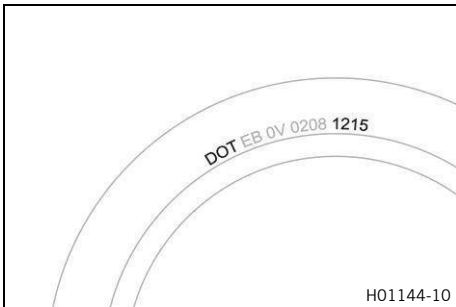

- Check the tire age.

i Note
 The tire date of manufacture is usually contained in the tire label and is indicated by the last four digits of the **DOT** number. The first two digits indicate the week of manufacture and the last two digits the year of manufacture.
 KTM recommends that the tires be changed after 5 years at the latest, regardless of the actual state of wear.

- » If the tires are older than five years:
 - Change the tires. 🛠️

15.6 Checking the tire pressure

i Note
 Low tire pressure leads to abnormal wear and the tire overheating.
 Correct tire pressure ensures optimal riding comfort and maximum tire service life.

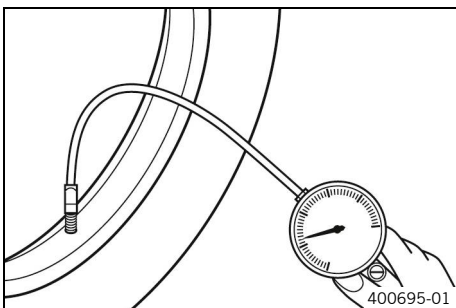

- Remove the protection cap.
- Check the tire pressure when the tires are cold.

Off-road tire pressure	
front	1.0 bar (14.5 psi)
rear	1.0 bar (14.5 psi)

- » If the tire pressure does not meet specifications:
 - Correct tire pressure.
- Mount the protection cap.

15.7 Checking the spoke tension



WARNING

Danger of accidents Incorrectly tensioned spokes impair the handling characteristic and can result in secondary damage.

If the spokes are too tight, they can break due to being overloaded.

Loose spokes can cause lateral or radial run-out in the wheel and other spokes will loosen as a result.

- Check the spoke tension regularly, especially on a new vehicle.

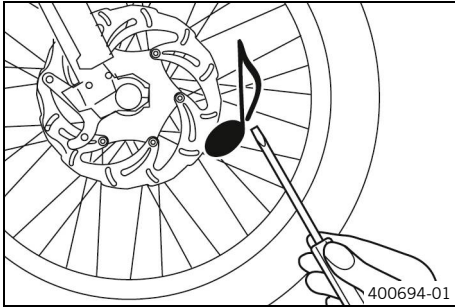

- Briefly tap each spoke with a screwdriver.

You should hear a high-pitched sound.



Note

The frequency of the sound depends on the spoke length and spoke diameter.

If spokes of the same length and diameter vibrate with a different tone, this is an indication that the spoke tensions differ.

- » If the spoke tension differs:
 - Correct the spoke tension. 
- Check the spoke torque.

Spoke nipple	
M3,5	3 Nm (2.2 ft·lb _f)

Torque wrench kit (58429094000)

16.1 Overview of battery charger

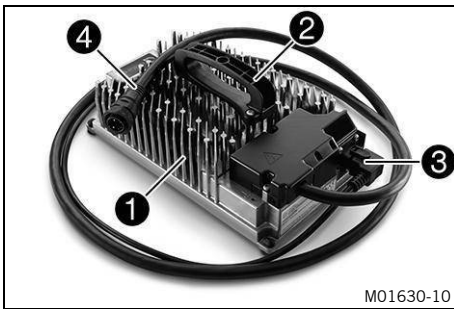

M01630-10

- ① Charger
- ② Carrying handle
- ③ Power cord
- ④ Charging cable

16.2 Positioning the battery charger



WARNING

Risk of injury There is a risk of electric shock if the battery charger or the cables have been manipulated or damaged.

The battery charger does not contain any parts which require maintenance.

- Do not modify the battery charger or the cables.
- Only use original cables.
- Do not open the housing of the charger.
- Do not insert any objects into the battery charger housing from the outside.
- Do not use the battery charger if cables, plugs, or parts of the battery charger have been damaged or are soiled.



WARNING

Risk of injury If the battery charger is used incorrectly, its intrinsic safety cannot be guaranteed.

The charger is only suitable for use with the vehicle's traction battery.

- Only use the charger with the vehicle's traction battery.
- Only operate the battery charger using household sockets with a ground conductor.
- Do not use any additional adapters or extensions.
- Follow the applicable safety instructions of the power connection.



Note

The battery charger contains sensitive electronics and must be handled with appropriate care.

The battery charger may be damaged or destroyed if it is dropped, knocked or otherwise subject to mechanical overload.

When transporting the battery charger, ensure appropriate means of securing the cargo.

Damage caused due to improper handling or improper transport is excluded from the manufacturer warranty.

The charger only complies with protection class **IP66** when using the original mains cable.

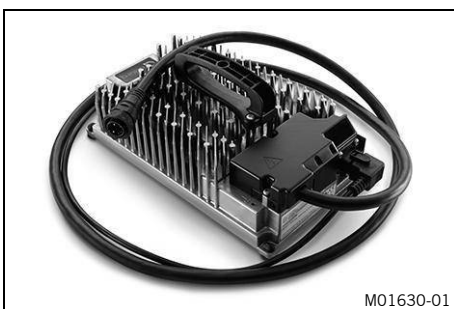

M01630-01

- Place the battery charger on a firm, level, and horizontal surface.

Despite protection class **IP66**, only use the charger in a dry environment, as moisture can penetrate when connecting and disconnecting the connections.

- Check the battery charger and mains cable for external damage.
- Ensure the battery charger is adequately ventilated.

Use the battery charger in the temperature range permitted.

Ambient temperature	-20 °C ... 50 °C (-4.0 °F ... 122.0 °F)
---------------------	--

- Ensure that the power plug for the battery charger always remains easily accessible.

16.3 Charging the LV traction battery



CAUTION

Danger of burns The metal housing of the charger becomes hot during operation.

- Only touch the battery charger by the carrying handle.
- After charging, allow the battery charger to cool before stowing it away.



NOTE

Material damage The voltage supply will be damaged if overloaded.

- Ensure that the power outlet can supply the steady current required and is protected by a suitable fuse.

Fuse protection at mains voltage 100 V minimum	15 A
Fuse protection for mains voltage 120 V minimum	13 A
Fuse protection for mains voltage 230 V minimum	10 A



NOTE

Environmental hazard The lithium ion accumulator contains elements and components that are harmful to the environment.

- Do not dispose of the LV traction battery in household waste.
- Dispose of the LV traction battery properly and in compliance with the applicable regulations.

Preparatory work

- Position the battery charger. (p. 87)
- Press and hold the On/Off button until the multifunctional element goes out.
- Remove magnetic switch from the support on the handlebar.

Main work

- Remove charging socket protection cap 1.

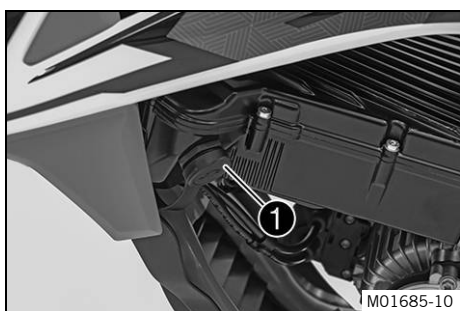

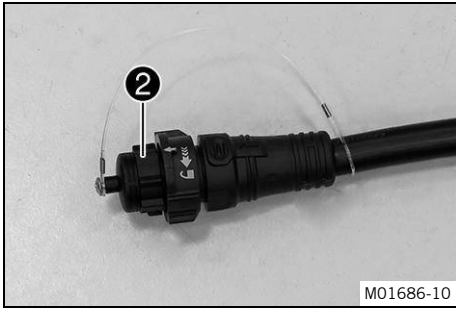

- Remove charging plug protection cap ②.

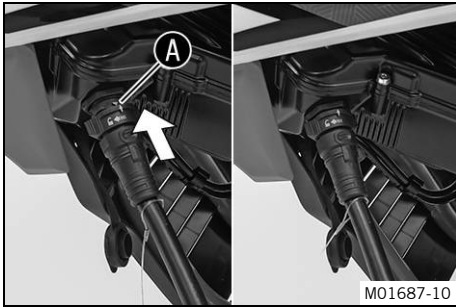

- Connect the charger to the LV traction battery and lock it clockwise.



WARNING

Risk of injury The intrinsic safety of the traction battery is only guaranteed if the original charger is used.

- Only use the original charger to charge the traction battery.

Do not activate the vehicle while the battery charger is connected to the LV traction battery.

Make sure that all plugs, bushings, and cables are dry.

Observe plug marking ①.

Insert the plug straight so that the contacts are not bent.



Note

If the vehicle is activated during the charging process, the vehicle switches to the malfunction state.



Note

If the temperature of the LV traction battery exceeds the permissible value while it is being charged, the battery charger stops charging. The malfunction is displayed on the multifunctional element.

Once the temperature of the LV traction battery returns to the permissible range, charging is resumed automatically.

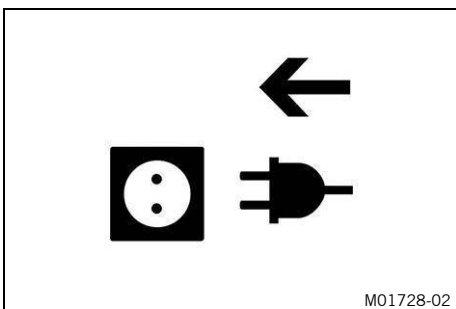

- Connect the power plug for the battery charger to the mains connection.
 - ✓ Charging starts automatically.
 - ✓ The multifunctional element indicates the charging level.
- Monitor the state of charge of the LV traction battery on the **multi-functional element**.



Note

It is recommended not to leave the vehicle unattended for long periods during charging.

When charging is complete, three beeps are emitted and all segments of the charging level indicator light up continuously.

- Press and hold the On/Off button until the multifunctional element goes out.

16 LV traction battery, battery charger

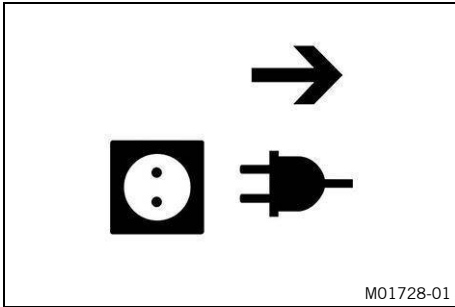

- Disconnect the battery charger power plug from the mains connection.

Make sure that all plugs, bushings, and cables are dry.

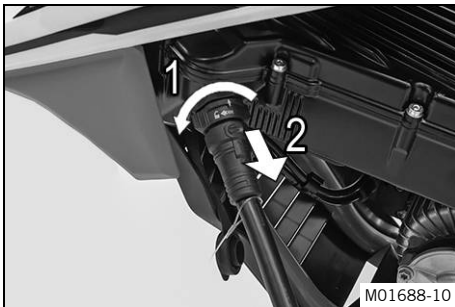

- Unlock the charging plug lock counterclockwise and disconnect the charging cable from the LV traction battery.

Pull on the structured part of the plug. Do not pull on the cable.

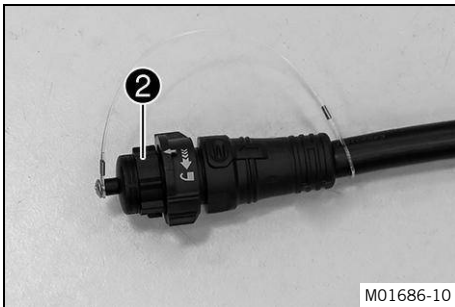

- Mount charging plug protection cap ②.

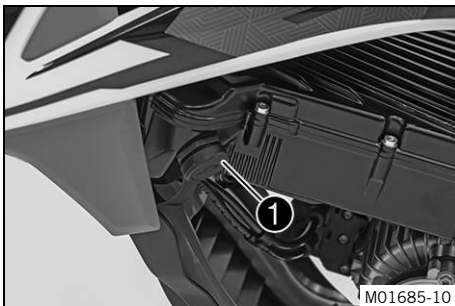

- Check charging socket protection cap ①.
 - » If the charging socket protection cap is dirty:
 - Clean the charging socket protection cap without water or compressed air.
 - » If the charging socket protection cap is damaged or worn:
 - Change the charging socket protection cap.
- Mount the charging socket protection cap.

Reworking

- Mount magnetic switch  on the support on the handlebar.

17.1 Cooling



The LV traction battery **1** is air-cooled.
The electric motor **2** is liquid-cooled.

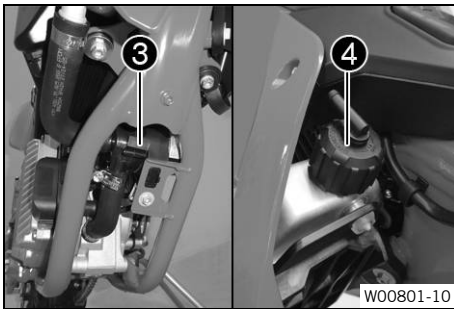

Water pump **3** in the engine circulates the coolant.
The pressure resulting from the warming of the cooling system is regulated by a valve in radiator cap **4**. This ensures that operating the vehicle at the specified coolant temperature will not result in a risk of malfunctions.

120 °C
(248.0 °F)

The coolant is cooled by the air stream.
The lower the vehicle speed, the lower the cooling effect. Dirty cooling fins also reduce the cooling effect.

17.2 Checking the frost protection and coolant level



WARNING

Health hazard Coolant is harmful to health.

- Keep coolant out of the reach of children.
- Do not allow coolant to come into contact with skin, eyes, or clothing.
- Consult a doctor immediately if coolant has been ingested.
- Rinse the affected area immediately with plenty of water in the event of contact with skin.
- Rinse eyes thoroughly with water and consult a doctor immediately if coolant comes into contact with eyes.
- If coolant spills on to your clothing, change the clothing.
- Store coolant properly in a suitable container and keep out of the reach of children.



WARNING

Danger of scalding The coolant heats up and is under high pressure when the vehicle is operated.

- Do not open the radiator, the radiator hoses, or other cooling system components if the engine or the cooling system are at operating temperature.
- Allow the cooling system and the engine to cool down before you open the radiator, the radiator hoses, or other components of the cooling system.
- In the event of scalding, rinse the area affected immediately with lukewarm water.

Condition: The engine is cold

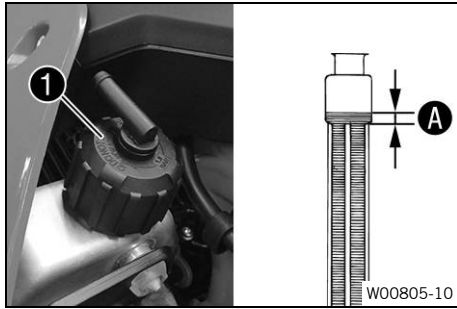

- Stand the motorcycle upright on a level surface.
- Take off radiator cap ❶.
- Check the frost protection in the coolant.

-45 °C ... -25 °C (-49.0 °F ... -13.0 °F)
--

- » If the frost protection in the coolant does not match the specified value:
 - Correct the frost protection in the coolant.

- Check the coolant level in the radiator.

Coolant level ❶ above the radiator fins	10 mm (0.39 in)
---	--------------------

- » If the coolant level does not meet the specifications:
 - Correct the coolant level.

coolant	
Coolant 📖 (p. 115) Antifreeze protection to at least: -25 °C (-13.0 °F)	0.4 l (0.11 liq. gal _{US})

- Mount radiator cap ❶.

17.3 Checking the coolant level



WARNING

Health hazard Coolant is harmful to health.

- Keep coolant out of the reach of children.
- Do not allow coolant to come into contact with skin, eyes, or clothing.
- Consult a doctor immediately if coolant has been ingested.
- Rinse the affected area immediately with plenty of water in the event of contact with skin.
- Rinse eyes thoroughly with water and consult a doctor immediately if coolant comes into contact with eyes.
- If coolant spills on to your clothing, change the clothing.
- Store coolant properly in a suitable container and keep out of the reach of children.



WARNING

Danger of scalding The coolant heats up and is under high pressure when the vehicle is operated.

- Do not open the radiator, the radiator hoses, or other cooling system components if the engine or the cooling system are at operating temperature.
- Allow the cooling system and the engine to cool down before you open the radiator, the radiator hoses, or other components of the cooling system.
- In the event of scalding, rinse the area affected immediately with lukewarm water.

Condition: The engine is cold

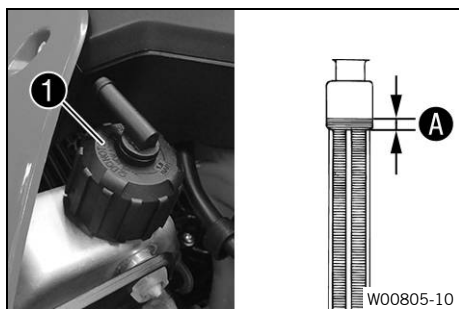

- Stand the motorcycle upright on a level surface.
- Take off radiator cap ❶.
- Check the coolant level in the radiator.

Coolant level ❶ above the radiator fins	10 mm (0.39 in)
---	--------------------

- » If the coolant level does not meet the specifications:
 - Correct the coolant level.

coolant	
Coolant 📖 (p. 115) Antifreeze protection to at least: -25 °C (-13.0 °F)	0.4 l (0.11 liq. gal _{US})

- Mount radiator cap ❶.



17.4 Draining the coolant 🛠️



WARNING

Health hazard Coolant is harmful to health.

- Keep coolant out of the reach of children.
- Do not allow coolant to come into contact with skin, eyes, or clothing.
- Consult a doctor immediately if coolant has been ingested.
- Rinse the affected area immediately with plenty of water in the event of contact with skin.
- Rinse eyes thoroughly with water and consult a doctor immediately if coolant comes into contact with eyes.
- If coolant spills on to your clothing, change the clothing.
- Store coolant properly in a suitable container and keep out of the reach of children.



WARNING

Danger of scalding The coolant heats up and is under high pressure when the vehicle is operated.

- Do not open the radiator, the radiator hoses, or other cooling system components if the engine or the cooling system are at operating temperature.
- Allow the cooling system and the engine to cool down before you open the radiator, the radiator hoses, or other components of the cooling system.
- In the event of scalding, rinse the area affected immediately with lukewarm water.

Condition: The engine is cold

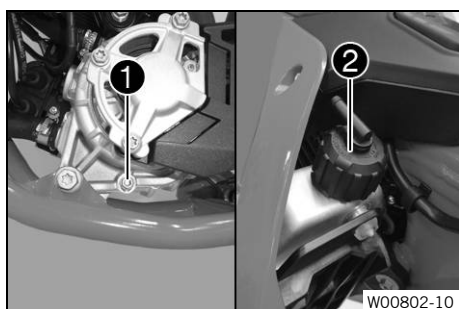

- Stand the motorcycle upright.
- Place an appropriate container under the water pump cover.
- Remove screw ❶.
- Take off radiator cap ❷.
- Completely drain the coolant.
- Mount screw ❶ with the new sealing ring and tighten.

Remaining screws on chassis	
M6	10 Nm (7.4 ft·lb _f)



17.5 Refilling the coolant



WARNING

Health hazard Coolant is harmful to health.

- Keep coolant out of the reach of children.
- Do not allow coolant to come into contact with skin, eyes, or clothing.
- Consult a doctor immediately if coolant has been ingested.
- Rinse the affected area immediately with plenty of water in the event of contact with skin.
- Rinse eyes thoroughly with water and consult a doctor immediately if coolant comes into contact with eyes.
- If coolant spills on to your clothing, change the clothing.
- Store coolant properly in a suitable container and keep out of the reach of children.

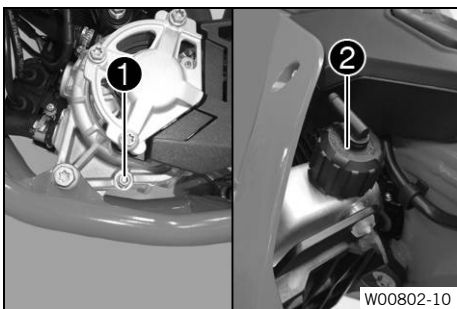

Main work

- Make sure that screw **1** is tightened.
- Stand the motorcycle upright.
- Take off radiator cap **2**.

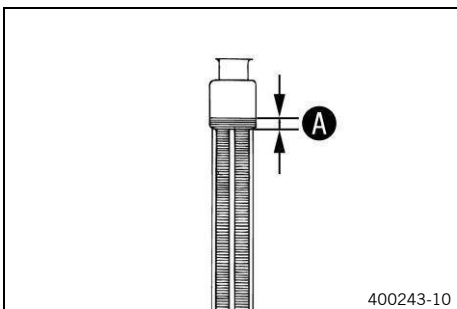

- Completely fill the radiator with coolant.

Coolant level A above the radiator fins	10 mm (0.39 in)
--	--------------------

coolant	
Coolant  (p. 115)	0.4 l (0.11 liq. gal _{US})
Antifreeze protection to at least: -25 °C (-13.0 °F)	

- Mount radiator cap **2**.
- Run the engine briefly and let it cool down again.
- Check the coolant level.  (p. 92)

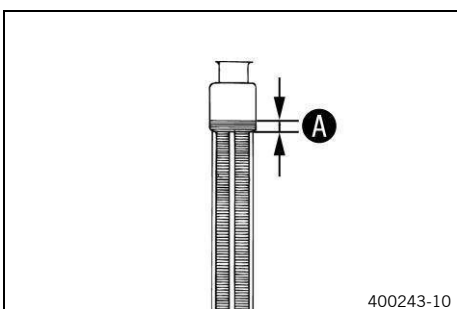

Reworking

- Check the transmission and cooling system for leaks.

17.6 Changing the coolant **WARNING****Health hazard** Coolant is harmful to health.

- Keep coolant out of the reach of children.
- Do not allow coolant to come into contact with skin, eyes, or clothing.
- Consult a doctor immediately if coolant has been ingested.
- Rinse the affected area immediately with plenty of water in the event of contact with skin.
- Rinse eyes thoroughly with water and consult a doctor immediately if coolant comes into contact with eyes.
- If coolant spills on to your clothing, change the clothing.
- Store coolant properly in a suitable container and keep out of the reach of children.

**WARNING****Danger of scalding** The coolant heats up and is under high pressure when the vehicle is operated.

- Do not open the radiator, the radiator hoses, or other cooling system components if the engine or the cooling system are at operating temperature.
- Allow the cooling system and the engine to cool down before you open the radiator, the radiator hoses, or other components of the cooling system.
- In the event of scalding, rinse the area affected immediately with lukewarm water.

Condition: The engine is cold

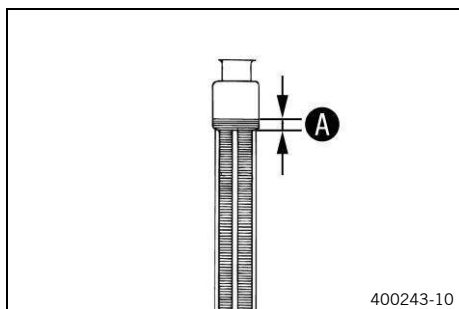
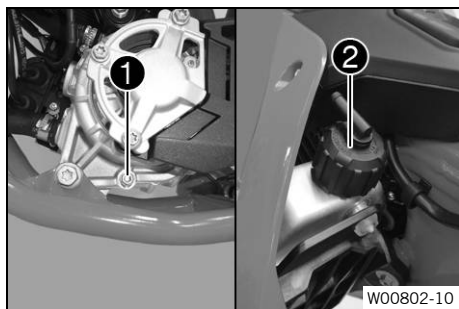
**Main work**

- Stand the motorcycle upright.
- Place an appropriate container under the water pump cover.
- Remove screw **1**.
- Take off radiator cap **2**.
- Completely drain the coolant.
- Mount screw **1** with the new sealing ring and tighten.

Remaining screws on chassis	
M6	10 Nm (7.4 ft-lb _r)

- Completely fill the radiator with coolant.

Coolant level A above the radiator fins	10 mm (0.39 in)
--	--------------------

coolant	
Coolant  (p. 115)	0.4 l (0.11 liq. gal _{US})
Antifreeze protection to at least: -25 °C (-13.0 °F)	

- Mount radiator cap **2**.
- Run the engine briefly and let it cool down again.
- Check the coolant level.  (p. 92)

Reworking

- Check the transmission and cooling system for leaks.

18.1 Cleaning the motorcycle



NOTE

Material damage Components can be damaged or destroyed if a high-pressure cleaner is used incorrectly. The high pressure forces water into the electrical components, socket connectors, clutch cables, and bearings, etc.

Too high a pressure can cause malfunctions and destroy components.

- Do not direct the water jet directly on to electrical components, socket connectors, clutch cables, or bearings.
- Maintain a minimum distance between the nozzle of the high-pressure cleaner and the component.

Minimum distance	60 cm (23.6 in)
------------------	--------------------



NOTE

Environmental hazard Hazardous substances cause environmental damage.

- Dispose of oils, grease, cleaning agents, brake fluid etc. properly and in compliance with the applicable regulations.



Note

Clean the motorcycle regularly to maintain its value and appearance over a long period. Avoid direct sunshine when cleaning the motorcycle.

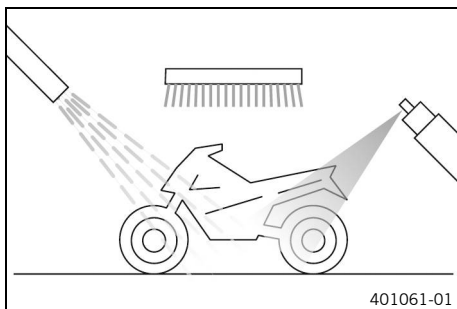

- Remove the coarse dirt particles with a gentle water jet.

Do not remove the bearing bridge of the engine sprocket during the entire operation.

- Spray the heavily soiled parts with a standard commercial motorcycle cleaner and clean using a brush.

Never apply motorcycle cleaner to a dry motorcycle; always rinse the vehicle with water first.

Environmentally neutral universal cleaning agent
 (p. 116)



Note

Use warm water containing standard motorcycle cleaner and a soft sponge.

- Clean the motorcycle thoroughly with a soft water jet, then allow to dry.



WARNING

Danger of accidents Moisture and dirt impair the brake system.

- Explain to your child that he or she must brake carefully several times to dry out and remove dirt from the brake linings and the brake discs.

- After cleaning, allow the child to ride for a short distance and brake carefully until the brake system has dried out.



Note

The heat causes the water to evaporate even in inaccessible parts of the vehicle.

- After the motorcycle has cooled off, lubricate all moving parts and pivot points.
- Clean the chain. (p. 62)



WARNING

Danger of accidents Oil, grease or wax on the brake discs reduces the brake action.

- Always keep the brake discs free of oil, fat and wax.
- Clean the brake discs with brake cleaner when necessary.

- Treat bare metal (except for brake discs) with a corrosion inhibitor.

Preserving materials (p. 116)

- Treat bare metal with a corrosion inhibitor.

Corrosion inhibitor must not come into contact with the brake discs.

Preserving materials (p. 116)

- Treat all plastic parts and powder-coated parts with a mild cleaning and care product.

Cleaning agents for plastics, glass, lacquers, metals, windshields and visors (p. 116)



19.1 Storage

i Note

If the vehicle will not be ridden for an extended period, additional steps are recommended.

Before storing the motorcycle, check all parts for function and wear. If service, repairs, or replacements are necessary, you should do this during the storage period (less overload of the authorized partner). This allows you to avoid long waiting periods when the next season starts.

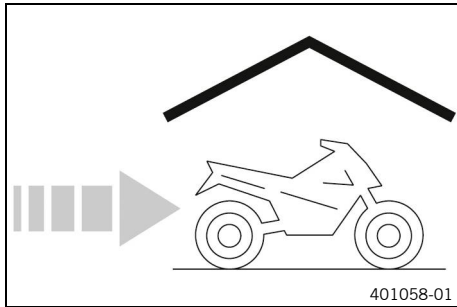

- Clean the motorcycle. (p. 96)
- Check the tire pressure. (p. 85)
- Charge the LV traction battery. (p. 88)

Stop charging at 30 %.

- ✓ The last segment lights up yellow.



Tip

If necessary, drain the LV traction battery sufficiently.

- Store the vehicle in a dry location that is not subject to large fluctuations in temperature.

Ideal storage temperature	10 °C ... 20 °C (50.0 °F ... 68.0 °F)
---------------------------	--



Note

KTM recommends jacking up the motorcycle.

- Raise the motorcycle with a lift stand. (p. 47)

Cover the motorcycle with a tarp or cover that is permeable to air.

Do not use any non-porous materials, as moisture cannot escape and corrosion can occur
--

19.2 Preparing for use after storage

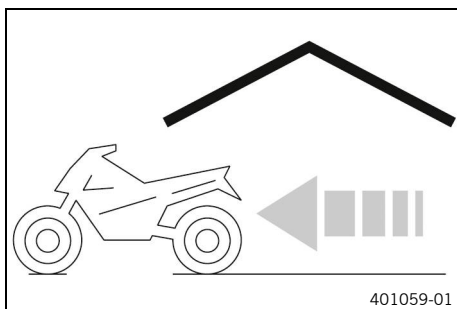

- Remove the motorcycle from the lift stand. (p. 47)
- Charge the LV traction battery. (p. 88)
- Perform checks and maintenance measures when preparing for use. (p. 27)
- Take a test ride.

20.1 Indicator light in case of malfunction



The malfunctions are indicated by malfunction indicator lamp **1** and by acoustic signals that sound at the same time.



Tip

As a first measure for all malfunctions, switch off the vehicle using the On/Off button, wait one minute, and switch it on again.

If a malfunction is not eliminated by the steps specified here, or the flash code is not listed, an authorized contractual partner will be happy to help you.



Note

The pause between the signals of the 1st digit is 0.25 seconds.

The pause between the 1st and 2nd digits is 1 second.





The pause between the signals of the 2nd digit is also 0.25 seconds.

The pause until the flash code repeats is 3 seconds.

20.2 troubleshooting

Cause	Finding	Remedy
Flash code 11	Malfunction of throttle grip	– Check the throttle grip for damage.
Flash code 12	Malfunction of throttle grip	– Check the throttle grip for damage.
Flash code 14	Throttle grip actuated during activation	– Do not operate the throttle grip during activation.
Flash code 24	System temperature too high	– Allow the vehicle to cool down, clean the cooling surfaces.
Flash code 31	Malfunction during charging	– Disconnect the battery charger from the vehicle and mains connection, wait 1 minute, restart the charging process.
Flash code 33	System temperature too high	– Allow the vehicle to cool down, clean the cooling surfaces.
Flash code 34	System temperature too low	– Park the vehicle in a warmer environment.
Flash code 41	Vehicle moved during activation	– Do not move the vehicle during activation.
Flash code 42	Motor speed outside the permissible range	– Do not roll backward with the vehicle.
Flash code 43	System temperature too high	– Allow the vehicle to cool down, clean the cooling surfaces.
Flash code 71	Malfunction during charging	– Disconnect the battery charger from the vehicle and mains connection, wait 1 minute, restart the charging process. – Replace the charging cable.
Flash code 72	Malfunction during charging	– Disconnect the battery charger from the vehicle and mains connection, wait 1 minute, restart the charging process. – Replace the charging cable.

20 Troubleshooting

Cause	Finding	Remedy
Flash code 73	Malfunction during charging	<ul style="list-style-type: none">– Disconnect the battery charger from the vehicle and mains connection, wait 1 minute, restart the charging process.– Replace the charging cable. 
Flash code 83	Transport mode activated	<ul style="list-style-type: none">– Deactivate the transport lock. 
Flash code 85	Malfunction during charging	<ul style="list-style-type: none">– Disconnect the battery charger from the vehicle and mains connection, wait 1 minute, restart the charging process.– Replace the charging cable. 
Flash code 88	Malfunction of on/off button	<ul style="list-style-type: none">– Deactivate the vehicle, wait 4 minutes, reactivate the vehicle.– Check the On/Off button for damage. 

21.1 Engine

21.1.1 Technical data - engine

Design	Brushless DC motor
Nominal power	2 kW (2.7 hp)
Maximum electric power	5 kW (6.7 hp)
Recuperation	available in ride mode 3 and 6
Maximum torque depending on ride mode approx.	
Riding mode 1	6 Nm (4.4 ft·lb _f)
Riding mode 2	9 Nm (6.6 ft·lb _f)
Riding mode 3	10.5 Nm (7.74 ft·lb _f)
Riding mode 4	12 Nm (8.9 ft·lb _f)
Riding mode 5	13.8 Nm (10.18 ft·lb _f)
Riding mode 6	13.8 Nm (10.18 ft·lb _f)
Theoretical maximum speed (unloaded)	
Riding mode 1	11 km/h (6.8 mph)
Riding mode 2	19 km/h (11.8 mph)
Riding mode 3	46 km/h (28.6 mph)
Riding mode 4	65 km/h (40.4 mph)
Riding mode 5	77 km/h (47.8 mph)
Riding mode 6	77 km/h (47.8 mph)
Maximum engine speed	6,000 rpm (100.00 Hz)
Cooling	Liquid cooling

21.1.2 Capacities - engine

coolant	
Coolant  (p. 115)	0.4 l
Antifreeze protection to at least: -25 °C (-13.0 °F)	(0.11 liq. gal _{US})

21.2 Chassis

21.2.1 Technical data - chassis

Frame	Central tube frame of chrome molybdenum steel tubing, powder-coated
Standard rider's weight	25 kg ... 35 kg (55.1 lb ... 77.2 lb)
Suspension travel:	
front	165 mm (6.50 in)
rear	190.5 mm (7.500 in)
Triple clamp offset	22 mm (0.87 in)
Brake system	
front	Disc brake with 2 piston brake caliper
rear	Disc brake with 2 piston brake caliper
Brake discs - diameter	
front	160 mm (6.30 in)
rear	160 mm (6.30 in)
Brake disc wear limit	
front	2.2 mm (0.087 in)
rear	2.2 mm (0.087 in)
Off-road tire pressure	
front	1.0 bar (14.5 psi)
rear	1.0 bar (14.5 psi)
Final drive	8:46
Chain	1/2 x 3/16"
Rear sprockets available	<ul style="list-style-type: none"> • 45 • 46 • 47
Steering head angle	66° (1.15 rad)
Wheelbase	1,020 mm (40.16 in)
Seat Height unloaded	646 mm ... 675 mm (25.43 in ... 26.57 in)
Ground clearance unloaded	229 mm (9.02 in)

Weight, when ready for use approx.	43 kg (94.8 lb)
Maximum permissible total weight	95.5 kg (210.54 lb)

21.2.2 Technical data - tires

Tire front	Rear tire
60/100 - 12 36J TT MAXXIS MAXXCROSS MX-ST+	2.75 - 10 38J TT MAXXIS MAXXCROSS MX-ST+
The tires specified represent one of the possible series production tires. For alternative manufacturers, if any, contact an authorized manufacturer or qualified tire dealership. If local road approval regulations apply, these and the respective technical specifications must be observed.	

21.3 Electrics

21.3.1 Battery

Air-cooled lithium-ion battery (LV traction battery)	A20146000000	Voltage (nominal): 43.2 V Capacity: 907 Wh (3,265,200 J) Approx. charging duration, 0 % to 80 %: 45 min Approx. charging duration, 0 % to 100 %: 70 min Maintenance-free
--	--------------	--

21.3.2 Charger

Battery charger for LV traction battery	45429074044	Nominal voltage: 100 V ... 240 V Grid frequency: 50 Hz ... 60 Hz (3,000 rpm ... 3,600 rpm) Power: 900 W (1.207 hp)
---	-------------	---

21.4 Fork



21.4.1 Technical data - fork

Fork part number	A400C102Z106102
Fork	WP XACT
Rebound damping	
Standard	15 clicks
Air pressure	
Standard	3.5 bar (50.8 psi)
Fork length	685 mm (26.97 in)
Spring rate	2 N/mm (11.4 lb _f /in)

21 Technical specifications

Spring length with preload spacer(s)	325 mm (12.80 in)
--------------------------------------	----------------------

21.4.2 Capacities - fork

Oil capacity, left outer assembly	
Fork oil (48601166S1) (SAE 4)  (p. 114)	25 ml (0.85 fl. oz _{US})
Oil capacity, right cartridge	
Fork oil (48601166S1) (SAE 4)  (p. 114)	205 ml (6.93 fl. oz _{US})
Grease capacity, left cartridge	
Special grease (00062010053)  (p. 114)	3 g (0.11 oz)

21.5 Shock absorber

21.5.1 Technical data - shock absorber

Shock absorber part number	A400C402X113000
Shock absorber	WP XACT 5735
Low-speed compression damping	
Comfort	18 clicks
Standard	15 clicks
Sport	12 clicks
High-speed compression damping	
Comfort	2.5 turns (900°)
Standard	2 turns (720°)
Sport	1.5 turns (540°)
Rebound damping	
Comfort	18 clicks
Standard	15 clicks
Sport	12 clicks
Preload	5 mm (0.20 in)
Spring rate	
Weight of rider: 15 kg ... 25 kg (33.1 lb ... 55.1 lb)	25 N/mm (142.8 lb _f /in)
Weight of rider (standard): 25 kg ... 35 kg (55.1 lb ... 77.2 lb)	30 N/mm (171.3 lb _f /in)
Weight of rider: 35 kg ... 45 kg (77.2 lb ... 99.2 lb)	35 N/mm (199.9 lb _f /in)
Spring length	130 mm (5.12 in)

Gas assisted	10 bar (145 psi)
Static sag	30 mm (1.18 in)
Rider sag	80 mm (3.15 in)
Installation position	275 mm (10.83 in)

21.6 Tightening torque

21.6.1 engine tightening torques

Nut for cable connection, motor	M6	9 Nm (6.6 ft·lb _f)
Screw, bearing bridge	M6×30	10 Nm (7.4 ft·lb _f)
Screw, engine case	M6×60	10 Nm (7.4 ft·lb _f)

21.6.2 Chassis tightening torques

Screw, strain relief	EJOT PT®	0.65 Nm (0.479 ft·lb _f)
Screw, cover for battery charger	M4	1.8 Nm (1.33 ft·lb _f)
Screw, fixed grip	M4	5 Nm (3.7 ft·lb _f)
Screw, throttle twist grip	M4	3 Nm (2.2 ft·lb _f)
Remaining screws on chassis	M4	3 Nm (2.2 ft·lb _f)
Remaining nuts on chassis	M4	3 Nm (2.2 ft·lb _f)
Screw, brake linings	M5	8 Nm (5.9 ft·lb _f)
Screw, brake line holder on link fork	EJOT Spiralform® – M5×10 – K	2 Nm (1.5 ft·lb _f)
Screw, carrying handle	M5	5.2 Nm (3.84 ft·lb _f)
Remaining screws on chassis	M5	5 Nm (3.7 ft·lb _f)
Remaining nuts on chassis	M5	5 Nm (3.7 ft·lb _f)
Screw, brake assembly	M5	5 Nm (3.7 ft·lb _f)
Nut, negative cable on battery charger	M6	2 Nm (1.5 ft·lb _f)

21 Technical specifications

Screw, chain slider guard	M6	3 Nm (2.2 ft·lb _f)
Screw, splash protector	M6	7 Nm (5.2 ft·lb _f)
Screw, front master cylinder	M6	5 Nm (3.7 ft·lb _f)
Remaining nuts on chassis	M6	10 Nm (7.4 ft·lb _f)
Remaining screws on chassis	M6	10 Nm (7.4 ft·lb _f)
Screw, rear brake disc	M6	14 Nm (10.3 ft·lb _f) Loctite® 243
Screw, front brake disc	M6	14 Nm (10.3 ft·lb _f) Loctite® 243
Screw, fork shoe	M6	10 Nm (7.4 ft·lb _f)
Screw, subframe connection	M6	10 Nm (7.4 ft·lb _f)
Rear fairing screw	M6	8 Nm (5.9 ft·lb _f)
Nut, push rod ball joint on the rear brake cylinder	M6	10 Nm (7.4 ft·lb _f)
Screw, brake pedal brake cylinder	M6	10 Nm (7.4 ft·lb _f) Loctite® 243
Screw, radiator on frame	M6	10 Nm (7.4 ft·lb _f)
Battery connections	M6	9 Nm (6.6 ft·lb _f)
Nut, push rod, foot brake lever	M6	6 Nm (4.4 ft·lb _f)
Screw, splash protector	M6	7 Nm (5.2 ft·lb _f)
Start number plate screw	M6	4 Nm (3.0 ft·lb _f)
Fender screw	M6	6 Nm (4.4 ft·lb _f)
Air duct on frame/spoiler bracket screw	M6	10 Nm (7.4 ft·lb _f)
Tail end lower part fastening screw	M6×12x3	4 Nm (3.0 ft·lb _f)
Engine bracket screw	M8	25 Nm (18.4 ft·lb _f) Loctite® 243
Nut, positive cable on battery charger	M8	2.6 Nm (1.92 ft·lb _f)

Rear brake caliper screw	M8×20	20 Nm (14.8 ft·lb _f) Loctite® 243
Nut, rim lock	M8	10 Nm (7.4 ft·lb _f)
Remaining nuts on chassis	M8	25 Nm (18.4 ft·lb _f)
Remaining screws on chassis	M8	25 Nm (18.4 ft·lb _f)
Screw, front brake caliper	M8×35	20 Nm (14.8 ft·lb _f) Loctite® 243
Screw, top triple clamp	M8	20 Nm (14.8 ft·lb _f)
Screw, bottom triple clamp	M8	15 Nm (11.1 ft·lb _f)
Subframe screw	M8	30 Nm (22.1 ft·lb _f) Loctite® 2701
Screw, chain slider	M8	15 Nm (11.1 ft·lb _f)
Screw, rear sprocket	M8	25 Nm (18.4 ft·lb _f) Loctite® 243
Bushing, brake pedal stop	M8	20 Nm (14.8 ft·lb _f)
Handlebar clamp screw	M8	20 Nm (14.8 ft·lb _f)
Screw, LV traction battery, front	M8×25	20 Nm (14.8 ft·lb _f)
Screw, LV traction battery, rear	M8×45	20 Nm (14.8 ft·lb _f)
Screw, steering stem	M8	20 Nm (14.8 ft·lb _f)
Screw, chain securing guide	M8	15 Nm (11.1 ft·lb _f)
Remaining nuts on chassis	M10	45 Nm (33.2 ft·lb _f)
Remaining screws on chassis	M10	45 Nm (33.2 ft·lb _f)
Top shock absorber screw	M10×42	45 Nm (33.2 ft·lb _f) Loctite® 243
Bottom shock absorber screw	M10×52	45 Nm (33.2 ft·lb _f) Loctite® 243

21 Technical specifications

Bushing, foot brake lever	M10	45 Nm (33.2 ft·lb _f) Loctite® 243
Screw, handlebar mount	M10	40 Nm (29.5 ft·lb _f) Loctite® 243
Screw, wheel spindle, front	M10	40 Nm (29.5 ft·lb _f) Loctite® 243
Nut, swingarm pivot	M12×1	40 Nm (29.5 ft·lb _f)
Nut, wheel spindle, rear	M12×1	70 Nm (51.6 ft·lb _f)
Screw, steering head	M16×1.5	10 Nm (7.4 ft·lb _f)
Spoke nipple	M3,5	3 Nm (2.2 ft·lb _f)
Screw, magnetic switch on handlebar	M3,5	0.8 Nm (0.59 ft·lb _f)
Screw, seat quick release thrust bearing	EJOT PT® – 35×16	0.75 Nm (0.553 ft·lb _f)
Remaining screws on chassis	EJOT PT® – K45×12	1 Nm (0.7 ft·lb _f)
Remaining screws on chassis	EJOT PT® – K50×12	1 Nm (0.7 ft·lb _f)
Remaining screws on chassis	EJOT PT® – K50×14	1 Nm (0.7 ft·lb _f)
Remaining screws on chassis	EJOT PT® – K50×16	2 Nm (1.5 ft·lb _f)
Remaining screws on chassis	EJOT PT® – K50×18	2 Nm (1.5 ft·lb _f)
Screw, brake line holder on fork protector	EJOT PT® – K60×20 – AL	2 Nm (1.5 ft·lb _f)
Remaining screws on chassis	EJOT PT® – K60×20	2 Nm (1.5 ft·lb _f)

22.1 Safety handbook

PARENTS, YOUNGSTERS & OFF-HIGHWAY MOTORCYCLES



THE MSF
DIRTBIKE
SCHOOL™

The information contained in this publication is offered for the benefit of those who have an interest in riding off-highway motorcycles. The information has been compiled from publications, interviews and observations of individuals and organizations familiar with the use of off-highway motorcycles. Because there are many differences in product design, riding terrain and riding styles, there may be organizations and individuals who hold differing opinions. Consult your local motorcycle dealers or experienced off-highway motorcycle riders about appropriate riding locations in your area. Although the Motorcycle Safety Foundation will continue to publish responsible viewpoints on this subject, it must disclaim specific or general liability for the views expressed herein.

The Motorcycle Safety Foundation® (MSF) is a national not-for-profit organization promoting the safety of motorcyclists with programs in rider training, operator licensing and public information. The MSF is sponsored by BMW, BRP, Ducati, Harley-Davidson, Honda, Kawasaki, KTM, Piaggio, Polaris Motorcycles, Suzuki, Triumph and Yamaha.

Motorcycle Safety Foundation
2 Jenner, Suite 150
Irvine, CA 92618
949.727.3227
msf-usa.org

Copyright 2015
Printed: March 2015

Parents...Be Cautious

Riding Off-Highway Motorcycles (OHMs) can be an enjoyable form of outdoor recreation when done properly. With preparation, practice, and parental supervision your youngster can safely develop and expand his or her riding skills. Remember, off-highway motorcycles are not toys.

This manual is designed to assist you in the important task of teaching your youngster the safe and responsible use of an off-highway motorcycle. We urge you to read this booklet thoroughly. Also read other information provided with the motorcycle. The owner's manual contains important warnings and features of the motorcycle.

Deciding if your youngster is ready to ride an off-highway motorcycle is an important decision. The MSF strongly urges you to carefully determine your youngster's readiness to ride. There is a Readiness Checklist in Part 4 of this booklet. **Do not permit youngsters to ride an off-highway motorcycle if you doubt that they will operate the motorcycle safely.**

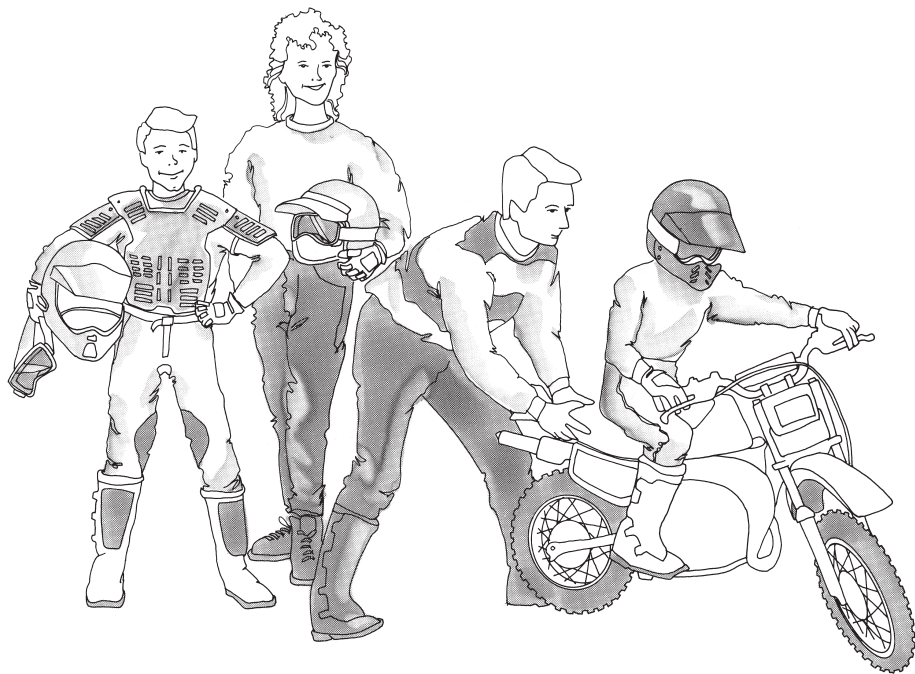

CONTENTS

INTRODUCTION

- Purpose of the Booklet 4
- Important Note to Parents 4
- Other Sources of Information 5

PART 1: Determining Your Youngster's Readiness to Ride an Off-Highway Motorcycle

- Readiness Guidelines 6
- Steps for Safe and
Responsible OHM Riding 10

PART 2: Pre-Operating Procedures and Practice

- Protective Gear and Clothing 11
- Mounting/Dismounting 12
- Mastering the Controls 13
- Learning Activities 16

PART 3: Operating Procedures and Practice

- Learning Area/Riding Area 20
- Getting Used to the Vehicle in
Motion 22
- Let's Start Riding 25

PART 4: Readiness Checklist

- Visual Perception/Motor/
Development 29
- Physical Development 32
- Social/Emotional Development 34
- Reasoning and Decision-Making
Ability 36

FINAL NOTE: To Parents 38

GLOSSARY 39

ANSWERS 41

INTRODUCTION

Purpose of the Booklet

Parents, *Youngsters and Off-Highway Motorcycles* is designed to assist you in determining if your youngster is ready to ride off-highway motorcycles (OHMs). It also provides you and your youngster with important safety information and tips on learning to ride. This booklet is divided into four parts: Part 1: Determining Your Youngster's Readiness to Ride an Off-highway Motorcycle; Part 2: Pre-operating Procedures; Part 3: Operating Procedures; Part 4: Readiness Checklist. There is information about protective gear, mounting, control operation and starting the engine. Operating procedures include starting, shifting, stopping and turning.

Important Note To Parents

Once your youngster is ready to learn to ride, YOU must be familiar with the motorcycle. You will be serving as teacher, coach, and safety supervisor for your youngster. You must know the controls, handling characteristics, maintenance requirements, and proper riding techniques. Read and understand the owner's manual and the labels provided with the vehicle. Review all instructions, requirements, and warnings with your youngster. Find out about state or local off-highway motorcycle requirements.

Other Sources Of Information

In addition to the information provided in *Parents, Youngsters and Off-Highway Motorcycles*, there are other sources for obtaining safety information. The owner's manual provides specific maintenance and operating procedures for your motorcycle. It also includes warnings and cautions, as well as operating tips. Motorcycle dealers may have other literature and safety information. Another booklet, *Tips and Practice Guide for the Off-Highway Motorcyclist*, gives detailed riding procedures.

The MSF *DirtBike School*SM offers training on how to ride off-highway motorcycles. The course is available to youth as young as six years of age, as well as to adults. Call toll-free 877.288.7093 to enroll or for more information. To find out more on the internet, visit dirtbikeschool.com.

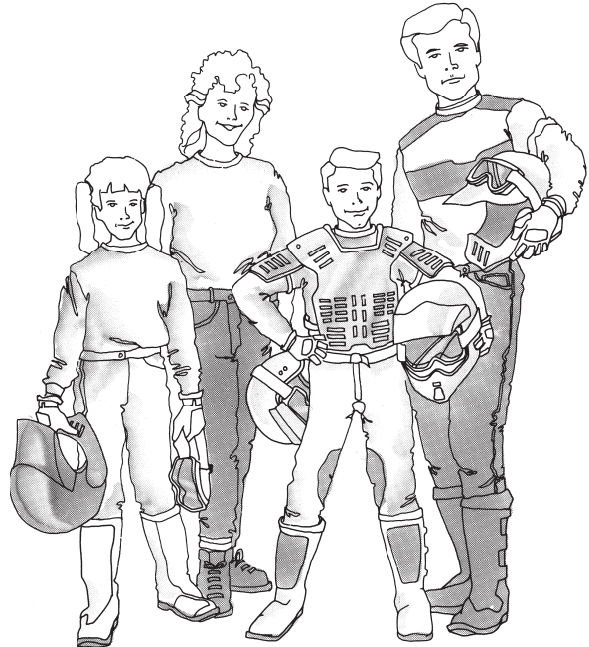

PART 1

DETERMINING YOUR YOUNGSTER'S READINESS TO RIDE AN OFF-HIGHWAY MOTORCYCLE

The first important decision you will have to make concerning your youngster and off-highway motorcycles (OHMs) is whether your youngster is ready to ride. There are several factors that you must consider carefully.

There is no certain way to predict that your child is able to ride an OHM safely. However, the following information is a guide to help you determine your youngster's readiness to ride. Only parents can decide if their youngster has the qualities necessary to operate an off-highway motorcycle safely.

Readiness Guidelines

PHYSICAL DEVELOPMENT

Physical size and ability are important considerations. For example, a youngster must be big enough to hold the motorcycle up, get on, and comfortably sit on the seat with both feet touching the ground.

Also make sure your youngster can comfortably reach and work all the controls. For example, can they turn the handlebars all the way to the right and left? Can they easily use their feet to work the brake pedal and gearshift lever? Can they operate the throttle and brake levers while they hold onto the handgrips? If not, the youngster is not physically ready to ride this OHM. Refer to the owner's manual to check for possible adjustments in the position of some of the controls.

PART 1

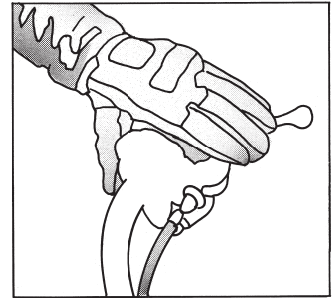
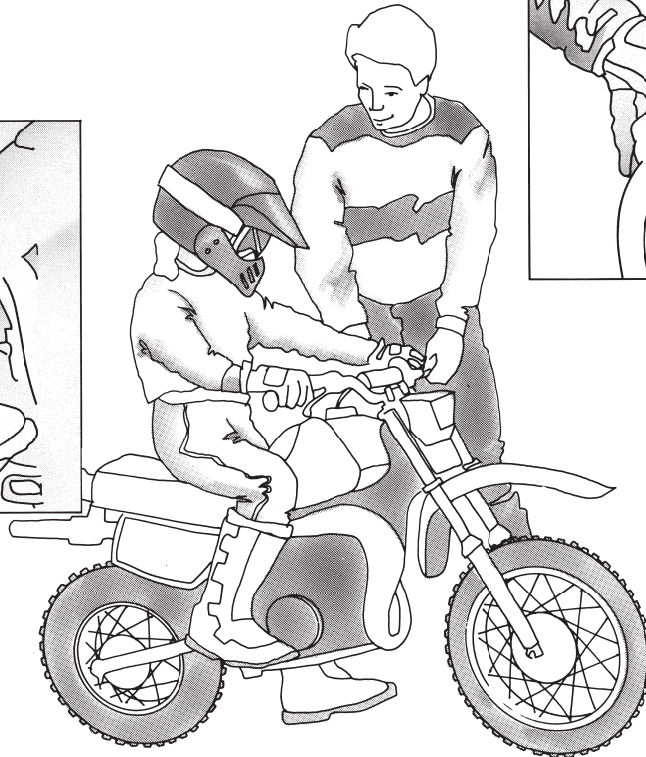
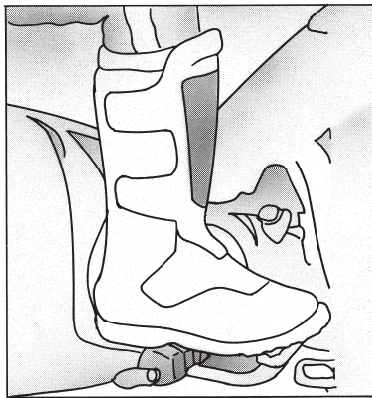

PART 1

Additional signs of physical readiness can be observed in your youngster's other play activities. In general, a youngster should be well-coordinated, having good balance and agility. This coordination can be demonstrated by the abilities to jump rope, skate, skateboard, ride a bicycle, etc. If a youngster cannot perform well in these types of activities, more physical development is needed.

SOCIAL/EMOTIONAL DEVELOPMENT

How a youngster behaves in a social setting can be a sign of social/emotional development. A youngster needs to know about and understand rules. Certain rules are necessary for the safe operation of any vehicle. Youngsters must be willing to follow rules. A good sign is a youngster who obeys rules set by parents. A youngster who does not follow rules is not ready for an OHM.

One indicator that a youngster is ready to ride an

OHM is when they demonstrate a safety-conscious attitude and are aware of possible injury from reckless OHM operation. If the youngster has a habit of recklessness or is often involved in accidents while using bicycles or skateboards, the youngster is not ready to ride an OHM.

REASONING AND DECISION-MAKING ABILITY

Youngsters should have some knowledge about what may happen if something is done wrong. They must understand that unsafe actions can result in injury. An example of this is knowing the need to look in both directions before crossing a street when walking to school. The ability to make good decisions relates to a youngster's ability to reason. When presented with a problem, the youngster should be able to come up with a sensible answer. Ask your youngster to tell you what causes accidents and injuries. Your youngster needs to be able to tell

what causes accidents and how to avoid them. In general, a youngster should understand that he or she can get hurt as a result of making poor choices.

VISUAL PERCEPTIONS AND MOTOR DEVELOPMENT

This area involves how well a youngster sees and how vision is used with other physical movements. In other words, can a youngster see and react with the proper hand, foot, or body movement?

Several types of visual characteristics are important. The ability to see to the sides while looking straight ahead is called peripheral or side vision. You can determine a youngster's side vision by having him or her look straight ahead while you move objects to the side. The youngster should be able to see objects ninety degrees to the side while looking straight ahead. Rider awareness and safety improves with good side vision.

Being able to judge distance is another visual skill helpful when operating an OHM. Is your youngster able to tell how far one object is from another, or which of two objects is closer? OHM riding requires a person to judge distance and react properly.

Being good at playing video games, hitting a baseball, etc., is a good sign that a youngster's eye and hand movements are fairly well coordinated.

In summary, you must consider many things before you decide to put your youngster on an OHM. There is no exact formula to use in making this decision. The Readiness Checklist, Part 4, can assist you with some points to evaluate. If you are not able to check-off most of the statements, your youngster is probably not ready to ride an OHM.

PART 1

Steps For Safe And Responsible OHM Riding

Once you determine that OHM use is proper for your youngster, it is time to prepare yourself as a good OHM teacher and supervisor.

STEP ONE: Educate Yourself about OHM Safety and Proper Riding Techniques

You must learn as much as possible about off-highway motorcycles in general, and especially your youngster's motorcycle. You must be qualified to instruct and supervise your youngster. This means that you will need to understand the features of the motorcycle and proper riding techniques. The best source of information is the owner's manual supplied with the motorcycle. Read the owner's manual before you begin to instruct your youngster about OHM safety. Pay particular attention to the warning labels and stickers on the motorcycle.

STEP TWO: Teach Your Youngster Safe and Proper Riding Techniques

Teaching your youngster off-highway motorcycling is a step-by-step process. It begins with safety rules and moves to actual riding techniques. Since youngsters learn at different rates, it will be up to you to set the pace of your youngster's progress. At some point you may decide that he or she is not ready to ride an OHM.

STEP THREE: Avoid Unsafe Situations Through Close Supervision

ALWAYS closely supervise your youngster's riding. This is true even if your youngster has learned and mastered the rules and skills of safe OHM riding. Youngsters can get tired easily and become careless. They do not always see everything that is important around them. Your close supervision and good judgment are important.

Protective Gear And Clothing

The nature of off-highway riding demands that your youngster wear proper protective gear. Motorcycle riders should ALWAYS wear a helmet, eye protection, gloves, long pants, a long-sleeved shirt or jacket, and over-the-ankle boots. Anything less is not adequate protection. NEVER let anyone ride an off-highway motorcycle without a Department of Transportation (DOT) compliant motorcycle helmet. Be sure the fit is correct. It should be snug but not tight. It must be properly fastened.

Protective gear is necessary in any weather, even when the temperature is warm. In cooler weather you should dress your youngster with additional layers of clothing. Some riders choose to wear a kidney belt and chest or back protector for additional protection. On the right is a drawing of well-equipped riders. Show this drawing to your youngster and point out what is important.

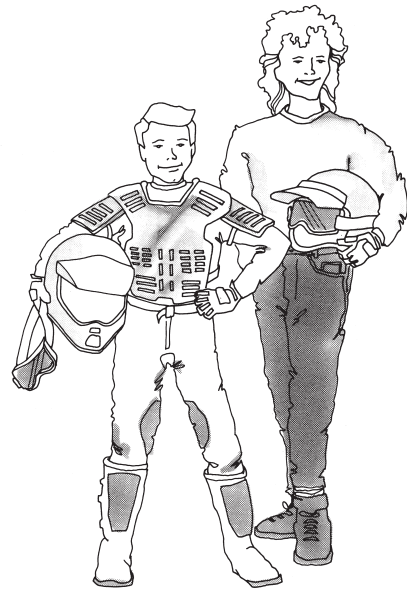

PART 2

Mounting/Dismounting

Have your youngster wear safety gear whenever getting on a motorcycle. This action will stress the importance of safety gear and help develop safe riding habits.

Mounting is typically from the left side. To mount from the left, point the handlebars straight. While squeezing the front brake lever, swing the right leg over the seat and place the right foot on the ground. Both feet should be in contact with the ground while sitting on the motorcycle. Dismounting reverses the procedure: the kickstand is placed fully down. With the left foot on the ground, the handlebars straight and the front brake lever squeezed, the right leg is swung over the seat and the foot touches the ground.

Correct riding posture helps your youngster operate the controls. Proper straight line riding posture includes:

- Head and eyes up, looking well ahead.
- Shoulders relaxed, back straight.

- Elbows bent, slightly out and away from the body.
- Hands on the handlebars.
- Knees in toward the tank.
- Feet on the footpegs, toes pointing straight ahead.

The hand and foot controls are important to riding safely. While riding, both hands should be kept on the handlebars and both feet on the footpegs of the motorcycle. Removing a hand or foot can reduce the ability to control the motorcycle.

An off-highway motorcycle rider will need to shift body weight in certain situations. This is especially true in maneuvers such as turning, negotiating hills, and riding on bumpy terrain. Your youngster should be able to operate the controls during these maneuvers. Now is a good time to make sure your youngster can reach the controls from different body positions. Have the youngster remount. Turn the handlebars full left

and full right. See that this can be done easily. Next have the youngster slide up and back on the seat. Mention that body movement is important. Body movement and shifting weight help to control the motorcycle.

(Go through these control exercises with the motorcycle's engine OFF.)

Mastering The Controls

Show your youngster how to use each control as you describe its action. Refer to the owner's manual to learn control location and function before instructing your youngster. Test yourself by operating the controls. Have your youngster dress in the proper protective gear and sit on the machine as you point out each control. It is important to have your youngster wear all the protective gear whenever sitting on an off-highway motorcycle.

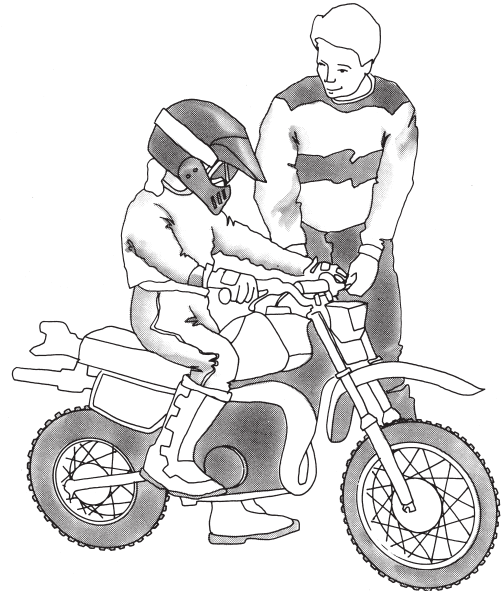

PART 2

BRAKES

Most small off-highway motorcycles have a hand lever on the right handlebar which operates the front brake. Most also have a foot pedal on the right side to operate the rear brake. Refer to the owner's manual for correct brake location and operation.

Explain and demonstrate proper braking procedure. Be sure your youngster can apply the brake(s) properly while seated and without looking down. Smooth operation should be encouraged.

THROTTLE CONTROL

Explain to your youngster that twisting the throttle control back will make the motorcycle go faster. Closing the throttle control slows the motorcycle.

Youngsters need practice using the throttle control smoothly. They tend to use it like an on/off switch. With the engine off, have your youngster

move the throttle to various positions. Practice turning the handlebars and using the throttle at the same time.

ENGINE STOP SWITCH

Explain to your youngster how to use the engine stop switch to turn off the engine. With the engine off, show how the stop switch works. Later, your youngster can practice using the stop switch when the engine is actually running.

CLUTCH/SHIFT LEVER

Some small OHMs do not have a clutch lever; some don't have a shift lever either. This section applies only to motorcycles with a shift lever. Those that do have a shift lever may have different shift patterns. Refer to your owner's manual for proper shifting instructions. It is important to learn how the shift lever works.

Explain that it is possible to shift the motorcycle with the shift lever in order to ride at different speeds.

Have your youngster practice shifting with the engine off. The shift lever, clutch lever (if equipped), and throttle control work together to move the motorcycle. When shifting to first gear from neutral the throttle is closed, the clutch lever is squeezed, and the front brake is applied before moving the shift lever into first gear. When starting out, the front brake is released. The throttle is gradually opened while the clutch is slowly released. If the clutch is released too quickly, or too much throttle is applied, the motorcycle may lunge forward causing loss of control. With the engine off, have your youngster practice upshifts, downshifts, and locating neutral.

SPEED LIMITERS

(supervisor control feature)

Some models come equipped with a removable exhaust restrictor, or another feature which reduces maximum speed. Refer to your owner's manual or talk to your dealer about this.

PART 2

NAME THE MOTORCYCLE PARTS (Typical)

Have your youngster write the number of the motorcycle part or control on the correct line for the diagrams shown. (*Answer Guide on Page 42*)

1. Clutch lever
2. Hand brake lever
3. Foot brake lever or pedal
4. Throttle
5. Choke or enriching device
6. Engine stop switch
7. Gas cap/tank vent
8. Starter (kick)
9. Electric starter (if equipped)

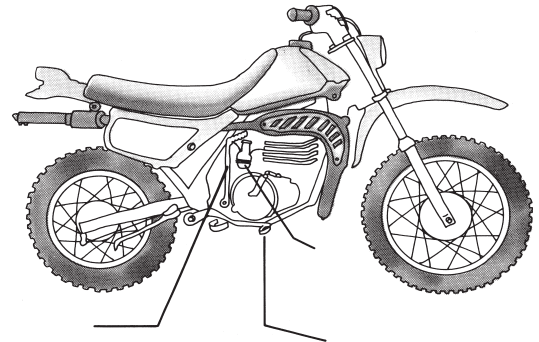
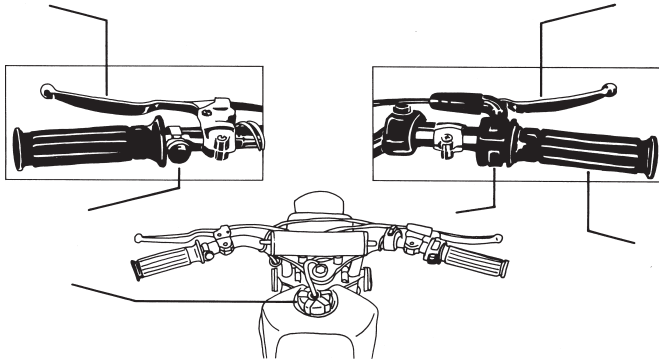

PART 2

LOCATING THE CONTROLS GAME

Now that you have shown your youngster the controls, it is your youngster's turn to show you. The engine remains OFF for this exercise and your youngster will be on the motorcycle. The youngster should be wearing the proper protective gear to develop this safety habit.

1. Have your youngster show you the location of the following:

- Brakes (lever and pedal)
- Throttle Control
- Engine Stop Switch
- Shift Lever (if equipped)
- Clutch (if equipped)

2. Have your youngster show you how the controls work. Be sure he or she understands the proper operation of each control. Skilled use of these controls should develop with practice. Under actual riding conditions the rider will have to watch ahead while operating the controls. Your youngster should be able to find the controls quickly without looking for them.
3. With your youngster looking ahead (pick out a point to look at), have him or her operate the controls. Repeat often while changing the order.
4. Ask your youngster to operate the controls as if actually riding. Look for smooth and precise operation.

PRE-RIDE CHECK

Before you continue:

1. Have you determined your youngster's readiness to ride an OHM? Do not let your youngster ride if you have any doubt. (Refer to the Readiness Checklist, Part 4)
2. Have you read the owner's manual and reviewed it with your youngster?
3. Does your youngster fit the motorcycle properly?
4. Have you inspected the vehicle and maintained it according to the owner's manual?
5. Is your youngster wearing the proper protective gear? Is the mounting procedure correct?
6. Has your youngster learned to locate the motorcycle controls without looking at them? Does he or she know how to operate them smoothly?
7. Does your youngster understand that he or she must always ride off-road?
8. Have you stressed to your youngster to keep his or her feet on the footpegs while riding?

If you have completely covered all these areas, you are ready to go on to Part 3.

PART 3

OPERATING PROCEDURES AND PRACTICE

Carefully observe your youngster's first use of the motorcycle. Observe his or her readiness to ride. Only permit your youngster to continue to ride if they have the size, strength, and attitude needed to ride safely.

Show your youngster the engine, exhaust pipe, and muffler. Tell him or her not to touch these parts because they are hot while the engine is running. Explain that they will remain hot after the engine is stopped. Also explain that hands and feet must be kept away from moving parts of the motorcycle.

Your youngster's safety depends in part on the mechanical condition of the motorcycle. Be sure to inspect it thoroughly before each use. Starting and refueling of the vehicle should be done by responsible adults only. Follow a regular maintenance program. See the owner's manual for inspection details.

Even after young riders have learned the basic riding skills, direct supervision by an experienced adult is necessary AT ALL TIMES. Make sure

that all off-highway motorcycle users under your supervision get proper riding instructions. Stress that an OHM is not a toy. Follow safety precautions strictly to provide a "safety first" approach to off-highway motorcycle riding. Teaching your youngster how to ride an OHM safely will increase the enjoyment of off-highway motorcycle riding.

Learning Area/Riding Area

The best place for learning is a level area 100' x 200' that is free from obstacles such as rocks, stumps, or holes. The learning area may have a loose or hard dirt surface. A grassy surface is also acceptable. It should not have two different surfaces. **Under no circumstances should the surface be concrete or asphalt.** Be sure there is room enough to maneuver, and that no other riders are close.

PART 3

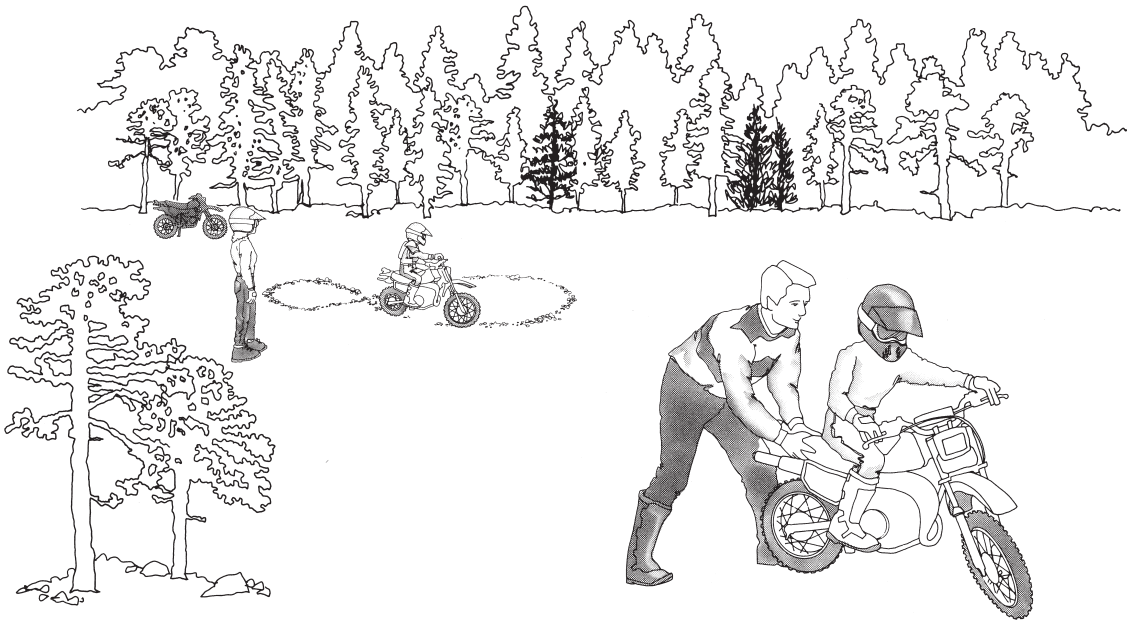

PART 3

Getting Used To The Vehicle In Motion

GETTING THE FEEL OF THE BRAKES

Be sure your youngster is wearing all of the proper protective gear. With the engine still OFF, have your youngster mount the motorcycle. If you physically can, push the motorcycle slowly. Have your youngster brake to feel how much pressure is needed for a smooth stop. If your youngster's motorcycle has more than one brake, both should be applied with even pressure. Practice this several times until you are sure this skill is developed. Remind your youngster to keep his or her head up and look forward.

GETTING THE FEEL OF THE THROTTLE

With the engine OFF, have your youngster practice smooth throttle control. Your youngster will learn how much throttle it takes to start moving in

a later exercise. Explain that opening the throttle will increase speed and that closing the throttle will decrease speed. Releasing the throttle and applying the brakes will slow the motorcycle. Ask your youngster to tell you how throttle control and braking affect the motorcycle's speed.

GETTING THE FEEL OF THE CLUTCH

(if equipped)

With the engine OFF, have your youngster practice smooth clutch control. Have your youngster shift the motorcycle into first gear. While you push the motorcycle have the youngster slowly release the clutch lever. The point which the motorcycle stops moving indicates the clutch engagement point or "friction zone." The "friction zone" is the point at which engine power begins to be transmitted to the rear wheel. Explain that this is the point the motorcycle will start moving when the engine is running. Smooth operation will prevent stalling and

allow smooth shifting. Remind the youngster that the throttle should be closed when shifting gears. Practice this exercise several times until the skill is developed.

GETTING THE FEEL OF TURNING

With the vehicle stopped and the engine OFF, have your youngster practice the proper turning technique:

1. For a right turn, look to the right and lean the motorcycle to the right.
2. For a left turn, look to the left and lean the motorcycle to the left.

Repeat this exercise with the kickstand up as you push the motorcycle. Make sure he or she can turn the vehicle in both directions using this technique while you maintain balance of the motorcycle.

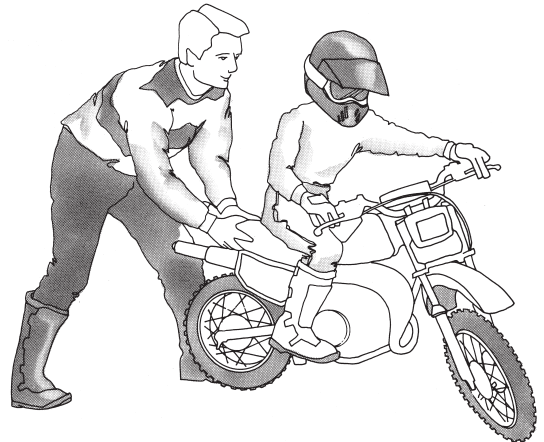

PART 3

BEING PREPARED FOR RIDING PRACTICE

Be sure to observe all the safety precautions covered in the Introduction and Parts 1 and 2. Double check that the riding area is free from hazards. Your youngster should wear all the proper protective gear, and the speed limiter (if equipped) should be installed and working correctly.

STARTING THE MOTORCYCLE

Always start the motorcycle for your youngster. To remember the proper starting technique use "FINE-C."

Double check for neutral. Start the engine. Have your youngster carefully mount. Let your youngster operate the engine stop switch and shut off the motor. Re-start the engine and repeat. Allow the engine to warm up until it runs smoothly with the choke off.

F	FUEL VALVE	Put to "on" position.
I	IGNITION	Ignition on.
N	NEUTRAL	Motorcycle in neutral (the motorcycle rolls with the clutch lever released).
E	ENGINE	Stop switch in run/on start position.
C	CHOKE	On (for cold engine only).

Let's Start Riding

Walk next to the motorcycle when your youngster first starts riding. You can also let the beginner ride back and forth between you and another adult. Help your youngster with the turns as he or she practices throttle control and braking.

STARTING OUT AND STOPPING

Before your youngster moves the motorcycle under power, take a few moments to practice smooth clutch control. After shifting to first gear, have your youngster rock the motorcycle a few inches back and forth by moving the clutch in and out of the "friction zone." The clutch is not fully released while doing this. It is important that clutch operation is smooth before riding in the practice area.

The next practice session is straight-line starts and stops. Keep the riding under control.

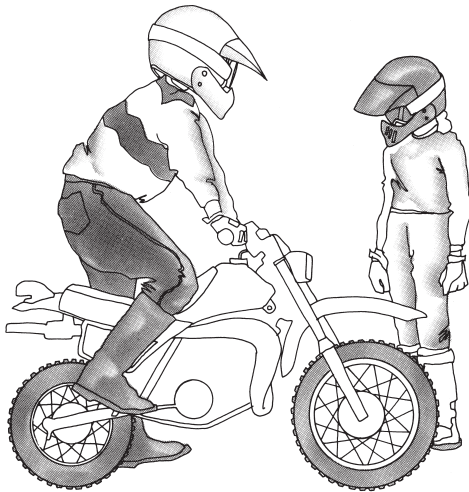

Start the motorcycle for your youngster

PART 3

However, riding too slowly will make balance more difficult. Both brakes should be used together for smooth stops. The left foot should be placed on the ground first, keeping the right foot on the rear brake.

Be sure your youngster develops a good feel for the use of the throttle and controls. After the youngster has mastered starting and stopping at slower speeds, increase speeds by shifting.

TURNING

Remind your youngster of the two steps for turning:

1. For a right turn, look to the right and lean the motorcycle to the right.
2. For a left turn, look to the left and lean the motorcycle to the left.

Have your youngster practice turning in both directions at slow speeds. Allow enough room to make a wide turn. After your youngster is skilled in making wide turns, try tighter turns.

Keep speed slow.

Your youngster should master these skills at low speeds before going faster. Next, practice some figure eights. This will help your youngster make left and right turns. Make sure your youngster keeps both feet on the footpegs and looks ahead in the turns.

Once these skills are mastered, refer to the [Tips & Practice Guide for the Off-Highway Motorcyclist](#), for additional skills used in off-highway riding.

PART 3

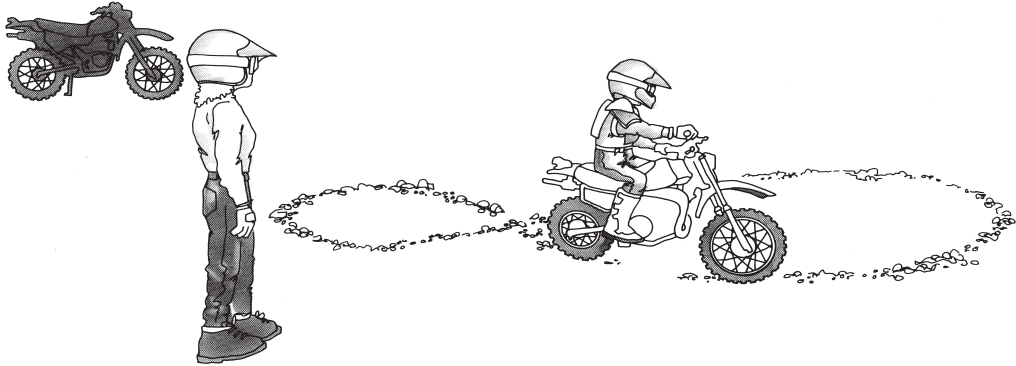

PART 4

READINESS CHECKLIST

This Readiness Checklist is provided to help you determine your youngster's readiness to learn to safely operate and control an OHM. There is a significant amount of judgment needed in determining a youngster's readiness to ride an OHM. The ultimate decision is the responsibility of the parent, guardian, or supervising adult. It is important that parents make informed decisions about whether or not their youngster becomes involved in off-highway motorcycle activity.

There are four developmental areas considered in the Readiness Checklist. These include: visual perception/motor development, physical development, social/emotional development, and reasoning and decision-making ability. Several questions are listed to help you determine if your youngster possesses the skills and capabilities to safely learn to operate an OHM.

The best way to utilize the Readiness Checklist is to read the particular ability, consider the answers to the questions for that ability, and check those abilities that you determine are present in your youngster. There are no suggestions as to how many abilities or the degree of ability that your youngster should possess. This Readiness Checklist may help you consider the appropriateness of OHM operation for your child. The ultimate decision for your youngster's involvement with off-highway motorcycles belongs to you, the parent.

VISUAL PERCEPTION/MOTOR DEVELOPMENT

Ability

1. Youngster can see with sufficient clarity.
2. Youngster possesses ability to perceive depth or distance.
3. Youngster has adequate side vision/ peripheral vision.
4. Youngster can judge the speed of objects.



Points to Evaluate

- Can youngster see letters and numbers at least as well as you?
- Can youngster distinguish colors?
- Has youngster demonstrated adequate vision in other activities (riding bicycles, running, sports, or other recreational activities)?
- When looking at two objects in the distance, can youngster tell which is farther or closer?
- Can youngster see objects 90 degrees to each side while looking straight ahead?
- Does the youngster judge the speed of objects (fast, medium, slow) that agree with your judgments? (For example, a car on the highway, a train moving past a crossing, a dog running, people walking.)

PART 4

Ability

5. Youngster can state the distances of objects in terms of feet, yard, miles.
6. Youngster can follow movement of objects.
7. Youngster can visualize distances as displayed by a picture or photograph.
8. Youngster can follow a moving object while accomplishing hand manipulation.
9. Youngster can describe cause-and-effect experiences.



Points to Evaluate

- Can youngster tell how many feet or yards it is from the house to the road?
- Can youngster tell how wide a hallway is, or the width of a room?
- Can youngster follow the path of such things as: a hit or thrown baseball, a moving car, objects in a video game?
- Can youngster estimate distance between objects in a family photograph?
- Can youngster estimate distance between objects when looking at a landscape picture?
- Can youngster dribble a basketball without looking at it?
- Can youngster manipulate video game controls while following objects on a screen?
- Can youngster describe a minor injury he or she received and correctly describe the causes?
- Can youngster describe settings or situations that can produce injury if precautions are not taken?

Ability

10. Youngster can concentrate on more than one element at a time in solving a puzzle or problem.
11. Youngster can maintain relative spans of attention when given a variety of stimuli.



Points to Evaluate

- Can youngster describe what may cause injury when doing such things as running, swimming, bicycling, riding in a car?
- Can youngster pick out or describe several items within a picture?
- Can youngster assemble a puzzle without unusual problems or delays?
- Can youngster describe what to do if a house fire should occur?
- Can youngster complete school homework assignments without being easily distracted?
- Can youngster assemble more difficult puzzles; for example, a nature scene or picture?

PART 4

PHYSICAL DEVELOPMENT

Ability

1. Youngster can sit comfortably on the motorcycle and reach the controls easily.
2. Youngster has sufficient strength and familiarity to operate the controls with ease.



Points to Evaluate

- Can youngster place his or her feet firmly on the footpegs?
- Do the youngster's fingers reach comfortably around the handlebars and control levers? How about with the handlebars turned? How about in different seating positions?
- Can youngster stand (with knees slightly bent) and have a few inches of space from the seat?
- Can youngster easily reach the foot controls?
- Can youngster dress with proper protective gear including putting on helmet and fastening the chin strap?

While sitting on the vehicle, can youngster:

- Squeeze the hand controls?
- Operate the shift lever (if equipped)?
- Operate the choke and fuel valve with ease?
- Press the brake lever with sufficient pressure
- Operate the controls without looking at them?

Ability

3. Youngster is sufficiently coordinated.



Points to Evaluate

Can youngster walk a "balance beam" (2" x 4" x 8') flat on floor?

Can youngster ride a bicycle, rollerskate or skateboard safely?

Can youngster walk on tiptoes for 10 feet?

Can youngster jump rope?

Can youngster catch a ball with hands rather than with arms?

4. Youngster has sufficient endurance to maintain strength over a period of time.

Can youngster play outdoor games without fatigue?

Can youngster participate in indoor games and sports without tiring before other youngsters?

PART 4

SOCIAL/EMOTIONAL DEVELOPMENT

Ability	✓	Points to Evaluate
1. Youngster can understand and follow rules.	<input type="checkbox"/>	Does youngster follow rules established at home?
	<input type="checkbox"/>	Do teachers say that the youngster follows rules?
	<input type="checkbox"/>	Does youngster listen and respond to adult supervision?
	<input type="checkbox"/>	Does youngster comprehend the importance and seriousness of having rules and regulations?
2. Youngster generally will obey parents and supervisors.	<input type="checkbox"/>	Does youngster avoid challenging authority or rebelling when rules are imposed?
3. Youngster controls behavior according to expectations?	<input type="checkbox"/>	Does youngster show evidence of self-control...doesn't get easily frustrated or upset?
	<input type="checkbox"/>	Does youngster understand consequences associated with certain actions (like not wearing a safety belt in the car)?
	<input type="checkbox"/>	Does youngster think about results before performing some action (like crossing the street, hitting or throwing a ball)?

Ability

4. Youngster understands other youngsters may be permitted to do what he/she may not be allowed to.

5. Youngster can give reasons and/or solutions to problems seen in the environment.

6. Youngster can make decisions based on reality and not fantasy.



Points to Evaluate

- Does youngster recognize unsafe actions of other youngsters?
- Does youngster appreciate being safer than others?
- Does youngster accept rules that are more stringent than what other youngsters have to follow?

- Can youngster explain how land (or grass) gets worn?
- Can youngster explain how even small damage to land can take years to recover?
- Can youngster distinguish between untouched land and used land?

- Can youngster complete a task in a step-by-step fashion (assemble a toy, clean a room)?
- Does youngster comprehend real injury as opposed to “cartoon” injury?
- Does youngster respond with logical solutions when asked to solve a problem?

PART 4

REASONING AND DECISION-MAKING ABILITY

Ability

1. Youngster comprehends that interaction with others and things can result in injury.
2. Youngster has a basic understanding of what being careful means.



Points to Evaluate

- Can youngster describe how and why a person received physical injury or pain?
- Does youngster notice impending accidents or potential injury-producing events, such as in sports activities or bicycle riding?
- Can youngster explain why it takes distance to stop?
- Can youngster explain how moving at even low speed can result in injury if stopped suddenly or by hitting something?
- Does youngster know why rules are established?
- Does youngster notice or recognize others being careful in action-oriented activities?
- Does youngster notice professional athletes use protective gear as part of their sport?

Ability

3. Youngster understands that rules are made to reduce injury and provide long-term enjoyment.
4. Youngster has basic understanding of the physical limitations of stopping and turning.



Points to Evaluate

- Can youngster explain the reason for rules at home or school?
- Does youngster understand the value of prevention? Of wearing protective gear?
- Can youngster recognize that not following rules can eliminate future fun and enjoyment?
- Can youngster explain what may happen if moving too fast while going around a curve on a bicycle? On a skateboard? On an off-highway motorcycle?

FINAL NOTE

TO PARENTS

We hope this booklet has helped you and your youngster take a “safety first” approach to off-highway motorcycle riding. All off-highway motorcycle riders must use good judgment and be responsible. It is up to YOU to set a good example about motorcycle safety. You must help your youngster ride sensibly and safely at all times.

After your youngster has mastered the riding skills in this booklet and has matured to a higher level of skills, he or she may be ready to practice more advanced riding. The Motorcycle Safety Foundation’s *Tips & Practice Guide for the Off-Highway Motorcyclist* booklet provides information about riding on hills, riding across slopes, and other more advanced skills. Youngsters should have a good understanding of riding skills before using unfamiliar areas. They

should ride on flat areas, gentle hills, and gradual slopes. Be sure that your youngster rides slowly over unfamiliar terrain to locate and avoid bumps, holes, and other possible hazards. You should check the area first.

The Motorcycle Safety Foundation also recommends a video program, *The MSF DirtBike School: Learn to Ride Safely*. It demonstrates and discusses responsible riding practices.

It is also recommended that you and your youngster read the information in the owner’s manual. To find out more about rider education and off-highway motorcycle safety programs offered, or to order the video or publications, contact the **Motorcycle Safety Foundation at 2 Jenner, Suite 150, Irvine CA 92618, 949.727.3227 or visit dirtbikeschool.com**

BRAKES - The parts of a motorcycle which allow the operator to slow down or stop the machine.

BRAKE LEVER - The hand brake located on the handlebar.

BRAKE PEDAL - The foot brake which is operated by the right foot.

CABLES - Heavy insulated wires. There are two kinds: mechanical and electrical. Brake cables are mechanical. The headlamp cable is electrical.

CARBURETOR - Device which provides the engine the proper mixture of fuel and air.

CHOKE - A device which enriches the mixture of gasoline and air supplied to the engine for cold engine starting.

CLUTCH LEVER - The hand lever used to disengage the clutch when changing gears.

DRIVE CHAIN - The chain which connects the engine to the rear axle to give a motorcycle motion.

ENGINE STOP SWITCH - Switch used to stop the engine without removing the hands from the handlebars.

EXHAUST - Leftover gases from the combustion process that come out of the tailpipe when the motorcycle engine is running. Exhaust contains deadly carbon monoxide gases.

EYE PROTECTION - Goggles or a shatter resistant shield worn over the eyes while riding to protect against dust, flying insects, or other debris. Such eye protection, when tinted, may be effective against bright sun or snow-glare conditions.

FINE-C - A pre-start routine. A way to remember the pre-start routine:

F - Fuel valve on

I - Ignition on

N - Neutral

E - Engine stop switch in run position

C - Choke

FOOTPEGS - Pivoting pegs on which a motorcycle operator should keep his/her feet while riding.

FUEL VALVE - A valve, usually hand operated, with an on, off and "reserve" position. Controls gasoline flow to the carburetor.

GLOSSARY

HANDLEBAR - The metal bar attached to the front end of the motorcycle that turns the front wheel for steering. Many of the controls for the motorcycle are located on the handlebar.

HELMET - The most important protective clothing to be worn when operating a motorcycle. It covers the head and helps protect against skull fracture or brain injury in an accident.

OFF-HIGHWAY or OFF-ROAD VEHICLE - Any vehicle, including off-highway motorcycles and ATVs, which is restricted by law from operating on public roads.

OHM - Off-Highway Motorcycle

PSI - Refers to air pressure in the tires and stands for "Pounds per Square Inch."

READING THE TERRAIN - Looking well ahead while riding, anticipating hazards.

SHIFT LEVER - On those motorcycles equipped with a shift lever, it allows the operator to change gears. The shift lever is operated by the left foot.

TAILPIPE - That part of the exhaust system which expels waste gases.

THROTTLE - The control operated by the right hand which controls the engine speed.

TRACTION - Tread friction between the ground and the tires.

TRANSMISSION - Mechanism used to transmit power from the engine to the wheels.

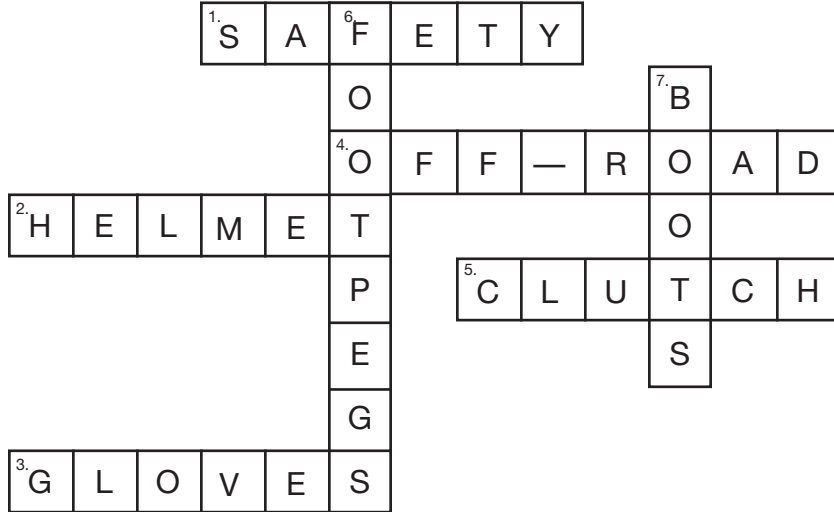

ANSWERS

NAME THE MOTORCYCLE PARTS (Typical)

1. Clutch lever
2. Hand brake lever
3. Foot brake lever or pedal
4. Throttle
5. Choke or enrichening device
6. Engine stop switch
7. Gas cap/tank vent
8. Starter (kick)
9. Electric starter (if equipped)

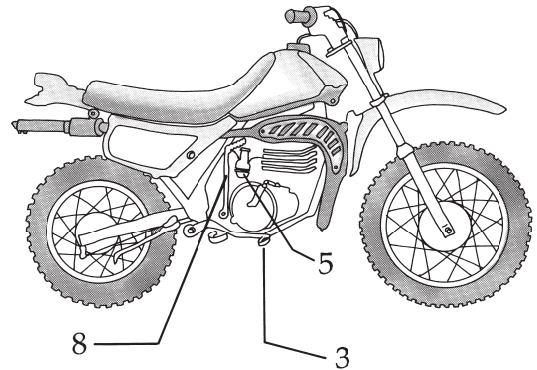
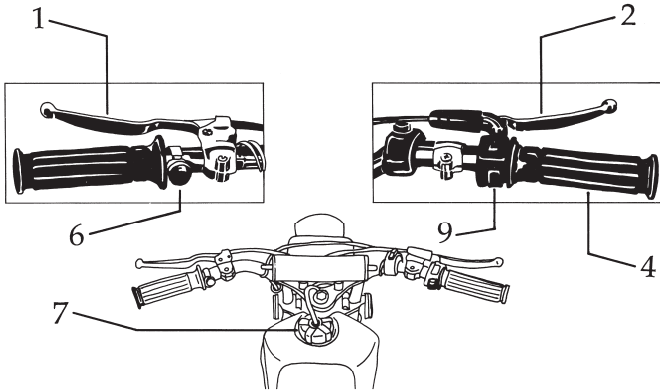

NOTES

NOTES



**For the rider training location nearest you,
call: (877) 288-7093**

dirtbikeschool.com

© 2015 Motorcycle Safety Foundation, Inc.
2 Jenner, Suite 150 • Irvine, CA 92618
(949) 727-3227 • msf-usa.org

PN MSPU3444NC00

23.1 Recycling

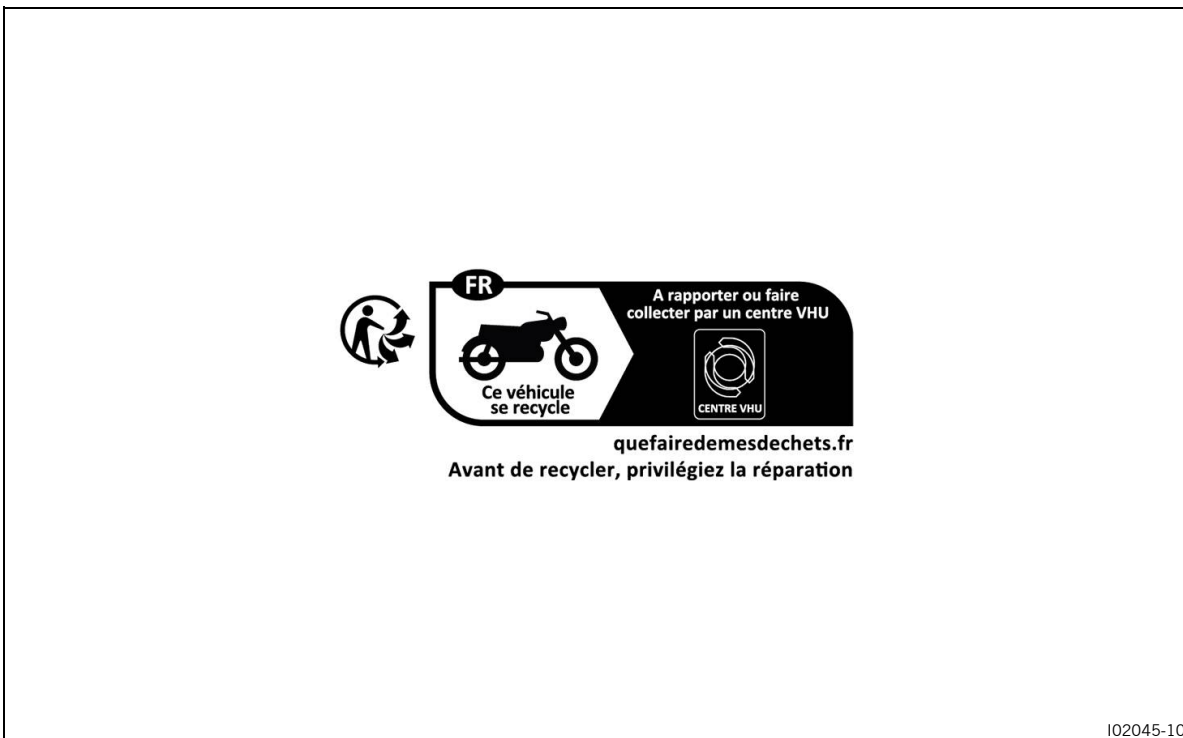

I02045-10

Further information is available at the following website.
 Recycling information website: <https://www.quefairedemesdechets.fr>

A Technical terms

BIN	Battery identification number	Serial number of the traction battery, which is linked to the vehicle identification number.
-----	-------------------------------	--

B Operating material

Off-road chain spray

Recommended supplier

MOTOREX®

- CHAINLUBE OFF ROAD

Fork oil

Order details

- 48601166S1

Standards

- SAE 4 → SAE

Universal oil spray

Recommended supplier

MOTOREX®

- JOKER 440 SYNTHETIC

Long-life grease

Recommended supplier

MOTOREX®

- Bike Grease 2000

High viscosity grease

Recommended supplier

SKF®

- LGHB 2

Special grease

Order details

- 00062010053

Recommended supplier

Klüber Lubrication®

- Klüberfood NH1 34–401

Brake fluid DOT 5.1

Recommended supplier

MOTOREX®

- BRAKE FLUID DOT 5.1

Standards

→ DOT

Coolant**Recommended supplier****MOTOREX®**

- COOLANT M3.0

Properties

- Antifreeze protection to at least -25 °C
(-13.0 °F)

C Cleaning agents

Chain cleaner

Recommended supplier

MOTOREX®

- CHAIN CLEAN

Preserving materials

Recommended supplier

MOTOREX®

- MOTO PROTECT

Cleaning agents for plastics, glass, lacquers, metals, windshields and visors

Recommended supplier

MOTOREX®

- QUICK CLEANER

Environmentally neutral universal cleaning agent

Recommended supplier

MOTOREX®

- MOTO CLEAN UNIVERSAL

D Icons**D.1 Symbol colors****D.1.1 Yellow and orange symbols**

Yellow and orange symbols indicate a malfunction status that requires prompt intervention. Active driving aids are also represented by yellow or orange symbols.

	Malfunction indicator light lights up/flashes.
---	--

A	
Accessories	13
Accident	9
Auxiliary substances	13
B	
Basic chassis setting	
rider's weight	33
Brake discs	
checking	68
Brake fluid	
adding front brake	70
adding to rear brake	77
Brake fluid level	
checking on front brake	69
checking on rear brake	76
Brake lining retainers	
checking on front brake	71
checking on rear brake	78
Brake linings (brake pads)	
changing on the rear brake	78
of the front brake, changing	72
Brake pad	
checking on front brake	71
Brake pads	
checking on rear brake	78
Brake pedal	
adjusting the basic position	75
checking the free travel	74
free travel, adjusting	74
C	
Camber	9
Chain	
checking	64
cleaning	62
Chain guide	
adjusting	66
checking	64
Chain tension	
adjusting	63
checking	63
Charger	
positioning	87
Charging	88
Coolant	
changing	95
draining	93
refilling	94
Coolant level	
checking	91...92
Customer service	13
D	
Defined use	11
E	
Engine	
work	10
Engine number	17
Environment	10
F	
Figures	13
Fire hazard	11
Fork legs	
adjusting the air pressure	39
bleeding	47
checking basic setting	39
cleaning the dust boots	48
installation	50
removing	49
Fork protector	
installation	49
removing	49
Frame	
checking	66
Front fender	
installation	57
removing	57
Front sprocket	
checking	64
Front wheel	
installing	81
removing	81
Frost protection	
checking	91
H	
Handbrake lever	
adjusting the basic position	68
checking the free travel	68
Handlebar position	
adjusting	41
High-speed compression damping	
adjusting the shock absorber	34
I	
Implied warranty	13
Improper use	12

Intended use	11	Rider sag	
L		adjusting	38
Lower triple clamp		Rubber grip	
installation	52	checking	67
removing	51	S	
Low-speed compression damping		Safe use	8
adjusting the shock absorber	34	Seat	
LV traction battery		mounting	59
charging	88	removing	59
work	10	Seat height	
M		adjusting on the fork	43
Manufacturer's warranty	13	adjusting on the frame	44
Motorcycle		adjusting on the shock absorber	42
cleaning	96	Service	13
raising with lift stand	47	Shock absorber	
removing from lift stand	47	adjusting the spring preload	37
N		checking the rider sag	37
Number plate		installation	58
installation	56	removing	57
removing	56	rubber buffer and pivot points, checking	58
O		static sag, checking	36
Operation		Side panel	
at low temperatures	14	securing	61
Owner's manual	11	Side panel left	
P		installation	60
Preparing for use		removing	59
after storage	98	Side panel right	
checks and maintenance measures when		installation	61
preparing for use	27	removing	60
notes on preparing for first use	25	Spare parts	13
Protective clothing	9	Spoke tension	
R		checking	86
Rear sprocket		Starting	27
checking	64	Steering head bearing	
Rear wheel		lubricating	56
installation	83	Steering head bearing play	
removing	82	adjusting	55
Rebound damping		checking	54
adjusting the fork	40	Storage	98
adjusting the shock absorber	35	Swingarm	
Rechargeable lithium-ion battery		checking	67
charging	88	T	
work	10	Tire condition	
Recycling	111	checking	84
Resources	13	Tire pressure	
		checking	85
		Transportation	30

V

Vehicle	
work	10
Vehicle identification number	17
VIN	17
Voltage supply	14



3240378en

19/05/2026

